Clarke®



Operator's Manual

BOOST™ 28

U.S. Patent No. 6,105,192; No. 6,557,207; No. 6,760,947; No. 5,383,251; & Patents Pending

READ THIS BOOK

▲ CAUTION: Read the Operator's Manual before using the appliance.

This book has important information for the use and safe operation of this machine. Failure to read this book prior to operating or attempting any service or maintenance procedure to your Clarke machine could result in injury to you or to other personnel; damage to the machine or to other property could occur as well. You must have training in the operation of this machine before using it. If operator(s) cannot read this manual, have it explained fully before attempting to operate this machine.

Si Ud. o sus operadores no pueden leer el Inglés, se hagan explicar este manual completamente antes de tratar el manejo o servicio de esta máquina.

All directions given in this book are as seen from the operator's position at the rear of the machine.

For new books write to: Clarke®, 2100 Highway 265, Springdale, Arkansas 72764.

Table of Contents



Operator Safety Instructions	3
Introduction & Machine Specifications	5
Procedures for Transporting Machine	6
Symbols Used on Boost 28	8
Machine Control Panel	9
Machine Controls and Features	10
How to Prepare the Machine for Operation	11
How to Install the Batteries	11
Battery Maintenance	12
How to Charge the Batteries (Remote Charger)	13
How to Charge the Batteries (On-Board Charger)	14
How to Install the Brush or Pad	15
How to Remove the Brush or Pad	15
How to Operate the Machine	16
How to Operate the Squeegee	16
Filling the Solution Tank	16
Operating the Machine	17
How to Clean a Floor	18
Maintenance	19
Procedures Before Work is Began	19
Procedures to Perform at the End of Work	20
Procedures to Perform Every Week	21
Maintenance for the Squeegee	22
How to Adjust the Squeegee	22
How to Center or Off set Brushhead	23
Accessories	24
How to Correct Problems in the Machine	25
 SECTION II - Parts and Service Manual	
Final Assembly Drawing	28
Parts List	29
Recovery Tank Drawing	30
Parts List	31
Solution Tank Assembly Drawing	32
Parts List	33
Rear Panel Assembly Drawing (Remote Charger)	34
Parts List	35
Rear Panel Assembly Drawing (On-Board Charger)	36
Parts List	37
Control Panel Assembly Drawing	38
Parts List	39
Squeegee Lift Assembly Drawing	40
Parts List	41
Squeegee Assembly Drawing	42
Parts List	43
Frame Axle Assembly Drawing	44
Parts List	45
Brush Head Assembly Drawing	46
Parts List	47
Optional Brake Assembly Drawing and Parts List	48
Vacuum Motor Drawing and Parts List	49
Transaxle Repair Parts	50
Battery Charger Drawing and Parts List	51
Connection Diagram	52
Electrical Schematic	53









OPERATOR SAFETY INSTRUCTIONS











 **WARNING**

 **AVERTISSEMENT**

 **ADVERTENCIA**

-  **DANGER:** Failure to read and observe all **DANGER** statements could result in severe bodily injury or death. Read and observe all **DANGER** statements found in your Owner's Manual and on your machine.
-  **WARNING:** Failure to read and observe all **WARNING** statements could result in injury to you or to other personnel; property damage could occur as well. Read and observe all **WARNING** statements found in your Owner's Manual and on your machine.
-  **CAUTION:** Failure to read and observe all **CAUTION** statements could result in damage to the machine or to other property. Read and observe all **CAUTION** statements found in our Owner's Manual and on your machine.

-  **DANGER:** Failure to read the Owner's Manual prior to operating or attempting any service or maintenance procedure to your Clarke machine could result in injury to you or to other personnel; damage to the machine or to other property could occur as well. You must have training in the operation of this machine before using it. If you or your operator(s) cannot read English, have this manual explained fully before attempting to operate this machine.
-  **DANGER:** Operating a machine that is not completely or fully assembled could result in injury or property damage. Do not operate this machine unless it is completely assembled. Inspect the machine carefully before operation.
-  **DANGER:** Machines can cause an explosion when operated near flammable materials and vapors. Do not use this machine with or near fuels, grain dust, solvents, thinners, or other flammable materials. This machine is not suitable for picking up hazardous dust. Use only commercially available floor cleaning waxes intended for machine operation.
-  **DANGER:** Lead acid batteries generate gases which can cause an explosion. Keep sparks and flames away from batteries. Do not smoke around the machine. Charge the batteries only in an area with good ventilation. Make sure that the AC charger plug is unplugged from the wall receptacle before connecting or disconnecting the DC plug to or from the battery pack.
-  **DANGER:** Working with batteries can be dangerous! Always wear eye protection and protective clothing when working near batteries. Remove all jewelry. Do not put tools or other metal objects across the battery terminals, or the tops of the batteries.
-  **DANGER:** Using a charger with a damaged power cord could result in an electrocution. Do not use the charger if the power cord is damaged.
-  **WARNING:** Operating this machine from anywhere other than the back of the machine could result in injury or damage. Operate this machine only from the rear.
-  **WARNING:** This machine is heavy. Get assistance before attempting to transport or move it. Use two able persons to move the machine on a ramp or incline. Always move slowly. Do not turn the machine on a ramp. Do not use on surfaces having a gradient exceeding that marked on the appliance. Read the "Procedures For Transporting" in this manual before transporting as machine might topple over if not secured.
-  **WARNING:** Machines can topple over and cause injury or damage if guided over the edges of stairs or loading docks. Stop and leave this machine only on a level surface. When you stop the machine, put all switches into their "OFF" position. Turn the key switch "OFF" and remove the key.

-  **WARNING:** Maintenance and repairs performed by unauthorized personnel could result in damage or injury. Maintenance and repairs must be performed by authorized Clarke personnel only.
-  **WARNING:** Any alterations or modifications of this machine could result in damage to the machine or injury to the operator or other bystanders. Alterations or modifications not authorized by the manufacturer voids any and all warranties and liabilities.
-  **WARNING:** Electrical components of this machine can "short-out" if exposed to water or moisture. Keep the electrical components of the machine dry. Wipe the machine down after each use. This appliance is for dry use only and is not to be used or stored outdoors in wet conditions.
-  **WARNING:** Operating a machine without observing all labels and instructional information could result in injury or damage. Read all machine labels before attempting to operate. Make sure all of the labels and instructional information are attached or fastened to the machine. Get replacement labels and decals from your Clarke distributor.
-  **WARNING:** Wet floor surfaces can be slippery. Water solutions or cleaning materials used with this type of machine can leave wet areas on the floor surface. These areas can cause a dangerous condition for the operator or other persons. Always put "Caution" signs around/near the area you are cleaning.
-  **WARNING:** Improper discharge of waste water may damage the environment and be illegal. The United States Environmental Protection Agency has established certain regulations regarding discharge of waste water. City, state and national regulations regarding this discharge may also be in effect in your area. Understand and follow the regulations in your area. Be aware of the environment hazards of chemicals that you dispose.
-  **WARNING:** Only use the brushes provided with the appliance or those specified in the Operator's Manual. The use of other brushes may impair safety.
-  **CAUTION:** Use of this machine to move other objects or to climb on could result in injury or damage. Do not use this machine as a step or furniture. Do not ride on this machine.
-  **CAUTION:** Your machine warranty will be voided if anything other than genuine Clarke parts are used on your machine. Always use Clarke parts for replacement.
-  **CAUTION:** This machine contains lead acid batteries. The batteries must be disposed of in an environmentally acceptable manner.

Introduction & Machine Specifications

Introduction & Machine Specifications

Clarke's newly designed BOOST 28 automatic scrubber is an efficient and superior floor cleaning machine. The BOOST 28 uses an orbital movement to scrub a path 28 inches wide. A squeegee wipes the floor while the vacuum motor removes the dirty solution from the floor - all in one pass.

The BOOST 28 comes complete with four - 6 volt batteries, one battery charger, a brush or a pad, and one operator's manual.

SPECIFICATIONS:

Model	BOOST 28
Machine Power Supply	24 Volt D.C., (4) 6V 250 AH Deep Cycle Batteries or (4) 6V 330 AH Deep Cycle Batteries
Pad or Brush	1 per Machine
Traverse	0.5 hp (0.4 kW) Transaxle
Traverse Forward Speed	Variable to 250 ft./min (76 m/min)
Traverse Reverse Speed	Variable to 190 ft./min. (58 m/min)
Battery Protection	Low Voltage
Motor Vacuum	3/4 HP, 3 stage, Acoustical High Efficient Tangential
Solution Tank	20 Gallons (76 liters)
Solution Level	Calibrated level indicator on rear of machine
Recovery Tank	20 Gallons (76 liters)
Recovery Full Indicator	Electric Shut-Off
Parabolic Squeegee	Swing type with breakaway feature, No tool operation feature 39 inches (99 cm) hard width with 41 inches (104 cm) flex blade width.
Squeegee Operation	Reverse direction on floor and 3 - position manual lever style operation
Cleaning Swath	28 inches (71 cm)
Motor, Brush	3/4 hp (0.56 KW)
Brush / Pad Size	14" x 28" (35.6 cm x 71 cm)
Brush Speed	2250RPM
Brush Pressure	100 lbs. (45.4 kg)
Drive Wheels	(2) 8 in. x 2 in. (20 cm x 5 cm) Neoprene tread
Caster	Dual 4 in. x 2 in. (10 cm x 5 cm)
Charger	24 V D.C., 25 Amp, 115/60, on-board optional
Grade Cleaning	5 Degree (6%)
Length	56.25 inches (143 cm)
Width	28.75 inches (73 cm)
Height	43 inches (109 cm)
Weight w/batteries (250 AH)	586 lbs. (266 kg)
Line of Sight (from Operator Height): 68 inches (173 cm)	7.5 feet (2.3 m)
Noise	71 dBA
Vibration	< 2.5 m/s ²

Procedures For Transporting

How to Put the Machine Into a Van or Truck

⚠ WARNING: This machine is heavy. Get assistance before attempting to transport or move it. Use two able persons to move the machine on a ramp or incline. Always move slowly. Do not turn the machine on a ramp. Do not stop and leave the machine on a ramp or incline. The loading ramp must be a minimum of 32" wide.

⚠ WARNING: Machines can topple over if guided over the edges of stairs or loading docks and cause injury or damage. Stop and leave this machine only on a level surface. When you stop the machine, put all switches into their "OFF" position.

1. Make sure the loading ramp is at least eight (8) feet (2.5m) long and a minimum of 32" (0.8m) wide, and strong enough to support the machine.
2. Make sure the ramp is clean and dry.
3. Put the ramp in position.
4. Remove squeegee assembly before loading. Clarke recommends that both the solution tank and recovery tank are empty before loading.
5. Turn key switch "ON" .
6. Align the machine on a level surface five (5) feet (2 m) in front of the ramp.
7. Put the traverse knob at full speed.
8. Push in either one of the forward/reverse switches while pushing in the white reverse switch. Back the machine up the ramp. See figure 1.
9. Turn the key switch "OFF".



Figure #1

Procedures For Transpoting (cont.)

10. **Fasten the machine to the vehicle.** Clarke recommends a strap over the top of the machine and a strap to keep the machine from rolling forward or backwards. If this is not done, there is a possibility of the machine toppling over. Four tie down points (2 along each side of frame) are provided on machine for securing machine.

How to Remove the Machine From a Van or Truck

1. Make sure there are no obstructions in the area.
2. Make sure the unloading ramp is at least eight (8) feet (2.5m) long and a minimum of 32" (0.8m) wide, and strong enough to support the machine.
3. Make sure the ramp is clean and dry.
4. Put the ramp in position.
5. Unfasten the machine.

⚠ WARNING: The machine is heavy. Make sure you use two able persons to assist in moving the machine down the ramp.

6. Turn the key switch "ON".
7. Set the traverse center knob to the slowest forward speed setting. Carefully and slowly, drive the machine to the top of the ramp and start down.
8. While pushing in the right or left forward/reverse switch the machine will go forward. See figure 2.
9. As the machine begins to travel down the ramp, push in the forward/reverse switch to maintain a slow downward speed.
10. Replace squeegee assembly after machine is unloaded and ready to use.

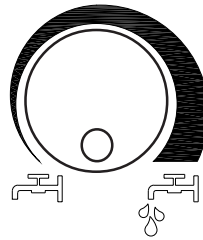

Figure #2

SYMBOLS USED ON BOOST 28



Warning



Solution Control



Power

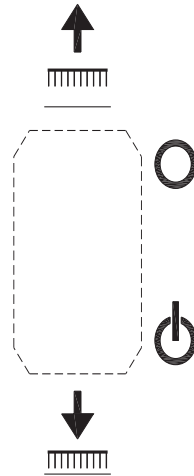

Brush Up/Down



Traverse Speed Control



Warning Label with parking brake



Warning Label without parking brake

Machine Control Panel

Key Switch (See Figure 3, Item "A")

The key switch turns "ON" the power to the control panel. "O" is "OFF" and "I" is "ON".

Forward Reverse Switch (See Figure 3, Item "B")

The forward/reverse switch turns the traverse motor "on" forward and if the brush motors are in the down position, activates the brush motor/solution control module. There is a two second delay for the pad motor to stop after releasing the switch. Either the right or the left switch can be used. Use either switch in conjunction with the white reverse switch to reverse the traverse motor.

Battery Meter (See Figure 3, Item "C")

The battery meter indicates the relative charge on the battery pack. Do not continue to run the machine when the needle is in the "red" area. This will shorten the life of the battery pack.

Reverse Switch (See Figure 3, Item "D")

The reverse switch, when used in conjunction with one of the forward/reverse switches, causes the machine to reverse directions. The reverse speed is 70% of the forward speed.

Vacuum Motor Switch (See Figures 4 & 5, pg. 10)

To activate vacuum motor, lower squeegee handle. Handle has two positions. Lowest position is operating position and the middle position is transport to clear vacuum hose.

Circuit Breakers (See Fig 3, Items "E", "F", "G", & "H")

The circuit breaker reset buttons are located on the rear cover. The breakers are located as follows:

- Item E - Actuator Head (5 amp)
- Item F - Vacuum Motor (30 amp)
- Item G - Brush Motor (30 amp)
- Item H - Traverse Motor (25 amp)

If a circuit breaker trips, determine which motor is not operating and turn the key switch "OFF". Wait five minutes and push the reset button back in. Turn the key switch "ON" and try again. An authorized service person should be contacted if the breaker trips again.

Control Handles (See Figure 3, Item "I")

The control handles are located at the rear of the machine. They are used to guide the machine.

Solution Control Knob (See Figure 3, Item "J")

The solution control knob regulates the flow of chemical solution to the floor. To increase the flow, turn knob clockwise. To decrease the flow, turn counter clockwise. Full counter clockwise is OFF and full clockwise is ON.

Traverse Speed Knob (See Figure 3, Item "K")

To increase speed, turn knob clockwise.

Brush Motor Switch (See Figure 3, Item "L")

To activate brush motor, push brush position switch to down position. Brush Motor and solution flow will activate when the traverse buttons are pushed. To shut brush motor off, place brush position switch in up position.

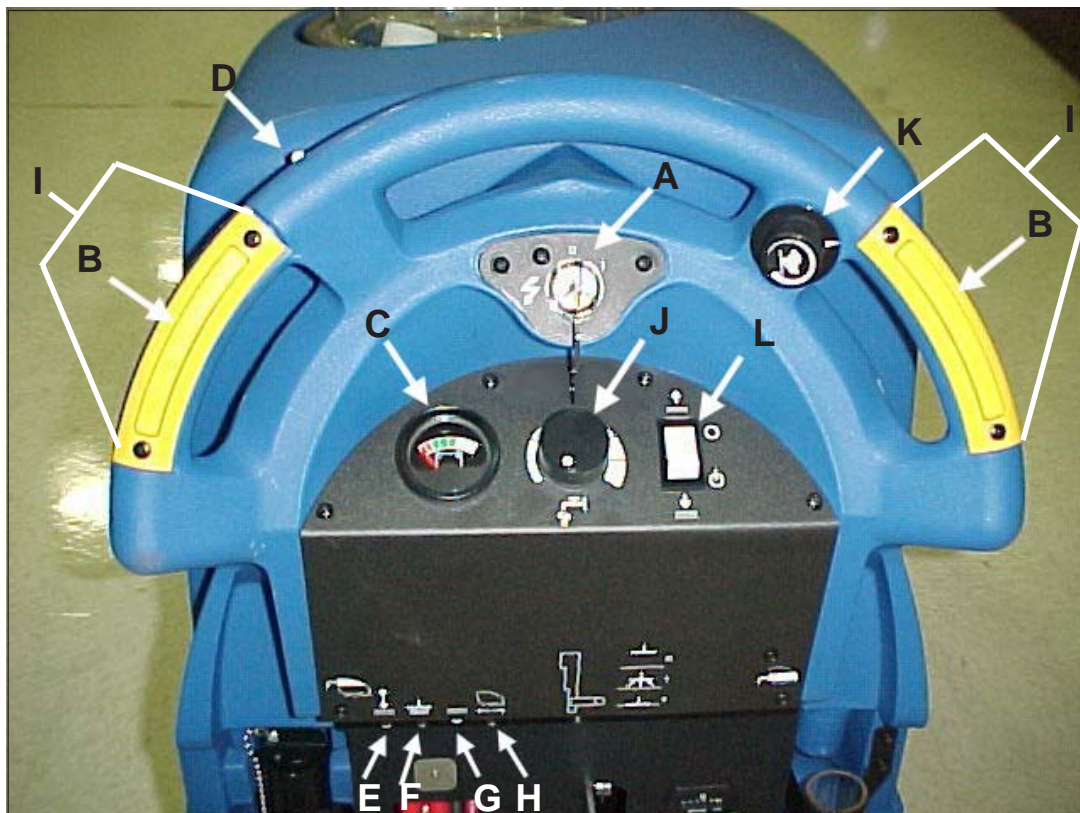

Figure 3

Machine Controls and Features

Squeegee Lift Handle, See Figures 4 and 5

The squeegee lift handle is located below the control handles in the center. It is used to raise or lower the squeegee. The vac motor is turned on when the handle is lowered to either the first or last position.

Float Shut Off, See Figure 6

The shut-off switch for the vac motor is located in the recovery tank. It automatically turns off the vac motor when the recovery tank is full. **NOTE: If excessive foaming occurs in recovery tank, defoamer must be added. Damage to vacuum motor could result from foam.**

Parking Brake (Optional), See Figure 7

NOTE: Parking Brake must be used if operating machine on greater than 2% gradient.

The parking brake prevents movement of the machine.

⚠ CAUTION: Do not activate the parking brake while the machine is moving.

The brake is located on the right hand side of the machine on the transaxle motor. Turn the key switch off or disconnect the power to the battery to apply the brake.

There is a mechanical lever located on the brake. This lever is an override. To manually release the brake, rotate the lever clockwise. To return the brake to normal or to apply the brake, rotate the lever up counter clockwise.

NOTE: If the lever is left in the override position, the brake will not function with the key switch, and the machine will not operate.



Figure 4



Figure 5

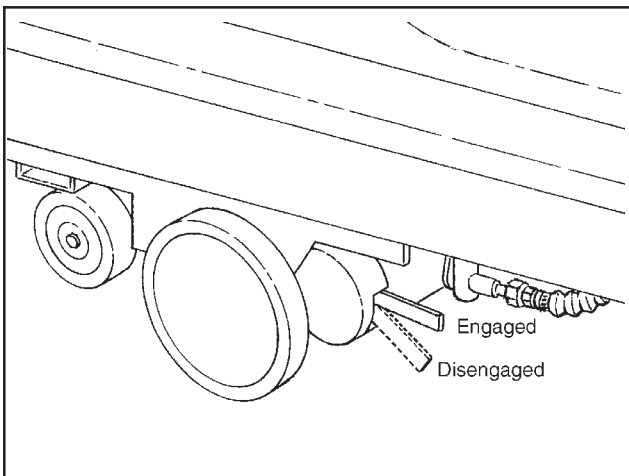

Figure 7



Figure 6

How To Prepare the Machine For Operation

How To Install The Batteries

This machine uses either two 12-volt batteries or four - 6 volt batteries. The batteries are located in the battery compartment under the recovery tank.

To install the batteries, follow this procedure:

1. Turn machine off. Set brake (if equipped).
2. Make sure recovery tank is empty.
3. Tip up the recovery tank until it locks in the full open position. See figure 8A.

CAUTION: Before raising the tank, be sure tank is empty.

NOTE: There is an intermediate position available for holding the recovery tank open for charging batteries. See figure 8B.

WARNING: Do not operate or perform maintenance on the machine while the recovery tank is in the intermediate position. The tank can be accidentally bumped and it may slam shut.

4. Place the batteries in the tray as shown in figure 8C.

WARNING: The batteries are heavy. Lifting batteries without help could result in an injury. Get help to lift the batteries.

WARNING: Working with batteries can be dangerous. Always wear eye protection and protective clothing when working near batteries. **NO SMOKING!**

5. Connect the cables between batteries and install long battery cable assembly as indicated. See figure 9.
6. Join the connector from the battery pack to the connector on the control panel.
7. Close recovery tank by pulling up on the latch arm and then slowly lowering the tank.

NOTE: Charge the batteries before using the machine.



Figure 8A



Figure 8B

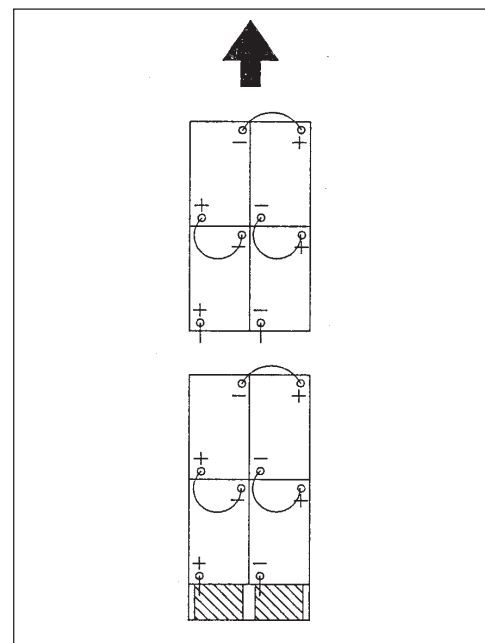

Figure 9

How To Prepare the Machine For Operation

Battery Maintenance

The electrical power to operate the machine comes from the storage batteries. Storage batteries need preventative maintenance.

⚠ WARNING: Working with batteries can be dangerous. Always wear eye protection and protective clothing when working near batteries. **NO SMOKING!**

To maintain the batteries in good condition, follow these instructions:

1. Keep the electrolyte at the correct level. The correct level is between 1/4" (1/2 cm) below the bottom of the tube in each cell and above the tops of the plates. Check the level of the electrolyte each time you charge the batteries. See figure 10.

NOTE: Check the level of electrolyte prior to charging the batteries. Be sure the plates in each cell are covered with electrolyte before charging. Do not top off the cells prior to charging the battery. Electrolyte expands during charging. As a result, the electrolyte could overflow from the cells. Always top off the cells with distilled water after charging.

⚠ CAUTION: Irreversible damage will occur to the batteries if electrolyte does not cover the plates. Keep the electrolyte at the correct level.

⚠ CAUTION: Machine damage and discharge across the tops of the batteries can occur if the batteries are over filled. Do not fill the batteries up to the bottom of the tube in each cell. Wipe any acid from the machine or the tops of the batteries. Never add acid to a battery after installation.

⚠ CAUTION: Batteries must be refilled with distilled water only. Do not use tap water as it may contain contaminants that will damage batteries.

2. Keep the tops of the batteries clean and dry. Keep the terminals and connectors clean. To clean the top of the batteries, use a damp cloth with a weak solution of ammonia or bicarbonate of soda solution. To clean the terminals and connectors, use a terminal and connector cleaning tool. Do not allow ammonia or bicarbonate of soda to get into batteries.

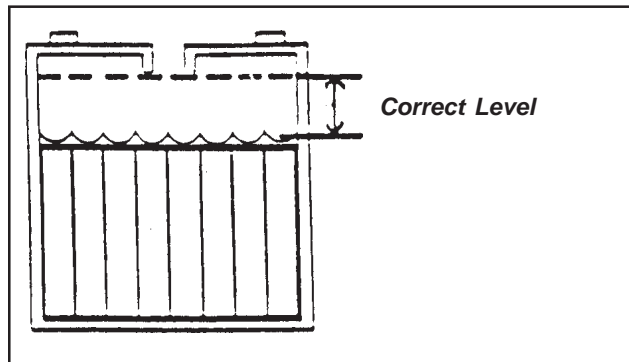

Figure 10

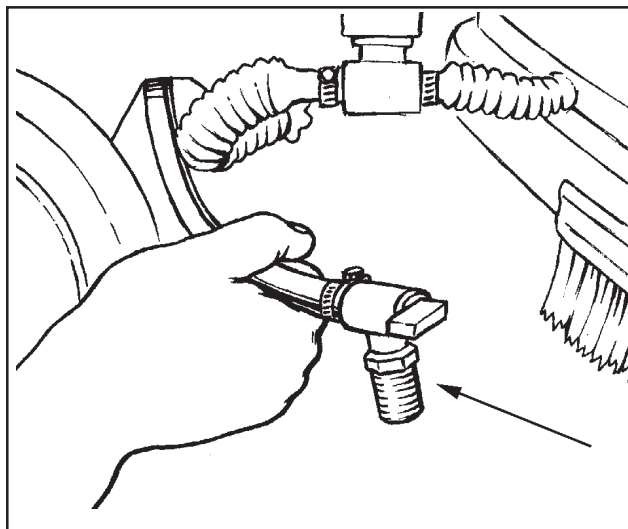

Figure 11

3. Keep the batteries charged.
4. To drain battery compartment: (See figure 11)
 - a. Always wear protective eye protection and protective clothing.
 - b. Add a weak solution of ammonia or bicarbonate of soda solution to battery compartment to neutralize any spilled acid.
 - c. Pull drain hose out from under transaxle.
 - d. Place hand behind flange and open valve.
 - e. When empty, close valve.
 - f. Replace valve and drain hose on top of transaxle.
 - g. Neutralize any acid spills with ammonia or bicarbonate of soda.

How To Prepare the Machine For Operation

How To Charge The Batteries

⚠ WARNING: Charging the batteries in an area without adequate ventilation could result in an explosion. To prevent an explosion, charge the batteries only in an area with good ventilation.

⚠ WARNING: Lead acid batteries generate gases which could explode. Keep sparks and flames away from batteries. **NO SMOKING!**

To charge the batteries, follow this procedure:

1. Make sure the key switch is in the "OFF" position.
2. Before charging the batteries, the battery compartment needs to be vented. To vent compartment, tip up the recovery tank until it locks in the open position (see figure 12A & 12B). To close the tank, pull up on the arm and then slowly lower the tank to the closed position.

⚠ CAUTION: Before raising tank, be sure tank is empty.

⚠ WARNING: Do not operate or perform maintenance on the machine while the recovery tank is in the open position. The tank can be accidentally bumped and it may slam shut.

3. Put the charger on a flat surface. Make sure the vents on the sides are at least two inches away from walls and other objects. Make sure there are no objects near the vents on the bottom of the charger.
4. Disconnect the battery pack connector from the batteries.
5. Connect the DC connector on the charger to the battery pack connector. See figure 12C.
6. Connect the battery charger AC cord to a 15 amp (min) 120V properly grounded wall receptacle.

NOTE: Make sure you plug into a circuit that is not loaded by other equipment. Wall breakers may be tripped and no charge will occur.

⚠ WARNING: Never charge a GEL battery with an unsuitable battery charger. Carefully follow the instructions given by the manufacturer of the batteries and battery charger.

NOTE: To prevent permanent damage to the batteries, avoid their complete discharge. Never leave the batteries completely discharged, even if the machine is not being used. When recharging the batteries, keep the recovery tank open. After every 20 recharging cycles, check the level of the electrolyte and if necessary top off with distilled water.



Figure 12A



Figure 12B

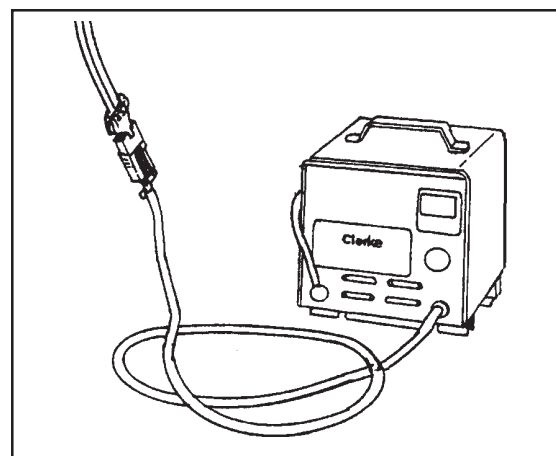

Figure 12C

How To Prepare the Machine For Operation

How To Charge The Batteries (On-Board Charger Option)

WARNING: Charging the batteries in an area without adequate ventilation could result in an explosion. To prevent an explosion, charge the batteries only in an area with good ventilation.

WARNING: Lead acid batteries generate gases which could explode. Keep sparks and flames away from batteries. **NO SMOKING!**

To charge the batteries, follow this procedure:

1. Make sure the key switch is in the "OFF" position.
2. Before charging the batteries, the battery compartment needs to be vented. To vent compartment, tip up the recovery tank until it locks in the open position (see figure 12A & 12B). To close the tank, pull up on the arm and then slowly lower the tank to the closed position.

CAUTION: Before raising tank, be sure tank is empty.

WARNING: Do not operate or perform maintenance on the machine while the recovery tank is in the open position. The tank can be accidentally bumped and it may slam shut.

3. Connect the battery charger AC cord located at the rear of the machine to a 15 amp (min) 120V properly grounded wall receptacle.
4. Observe indicator light on the charger to ensure the charging process has started. Yellow light indicates state of charge. Steady on green light indicates the batteries are fully charged.

NOTE: Make sure you plug into a circuit that is not loaded by other equipment. Wall breakers may be tripped and no charge will occur.

WARNING: Never charge a GEL battery with an unsuitable battery charger. Carefully follow the instructions given by the manufacturer of the batteries and battery charger.

NOTE: To prevent permanent damage to the batteries, avoid their complete discharge. Never leave the batteries completely discharged, even if the machine is not being used. When recharging the batteries, keep the recovery tank open. After every 20 recharging cycles, check the level of the electrolyte and if necessary top off with distilled water.



Figure 12A



Figure 12B

How To Prepare the Machine For Operation

How To Install The Brush Or Pad

To install the brush or pad on the machine, follow this procedure:

1. Turn the key switch "ON".
2. Put the brush switch in the "Up" position.
3. Turn the key switch "OFF".
4. Go to the front of the machine.
5. Press on a brush or pad, under the flex plates. See figure 13.

NOTE: When using a black pad, position pad on head. Lower head and operate momentarily to affix pad to pad driver (if you have difficulty, position pad on floor and lower head then operate.)

How To Remove The Brush Or Pad

To remove the brush or pad from the machine, follow this procedure:

1. Turn the key switch "ON".
2. Put the brush switch in the "Up" position.
3. Turn the key switch "OFF".
4. Go to the front of the machine and pull downward on the brush or pad until it releases from the flex plates. See figure 14.

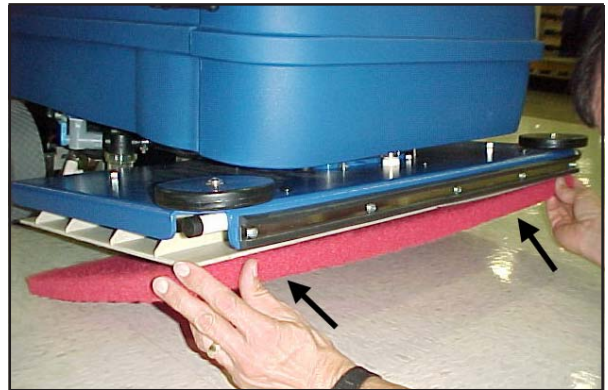

Figure 13

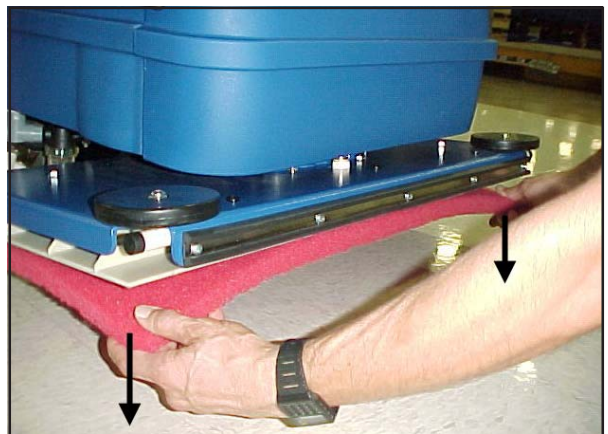

Figure 14

How To Operate The Machine

How To Operate The Squeegee

The squeegee wipes the floor while the vacuum motor removes the dirty solution from the floor. Use your hand to lower or raise the squeegee handle. To operate the squeegee, follow this procedure:

1. To lower the squeegee and start the vacuum motor, move the squeegee lever to the right and down. See figure 15.
2. To raise the squeegee, lift the squeegee lever up. See figure 16.

NOTE: The center position lets the vacuum motor continue to run with the squeegee off the floor to avoid drips and also allows you to back up the machine.

How To Fill The Solution Tank

The solution tank can be filled in the front or through the clear drain hose at the rear of the machine (See figure 17). To fill the solution tank follow this procedure:

1. Add a cleaning chemical to the solution tank. For the correct amount of chemical, follow the directions shown on the container.
2. Fill the solution tank with water. When filling machine in the front with a hose, position hose inside the fill screen as shown in figure 17A.

When filling machine from the rear, position clear drain hose against bracket and insert hose as shown in figure 18. Solution level can be viewed from the back of the machine.



Figure 15



Figure 16



Figure 18

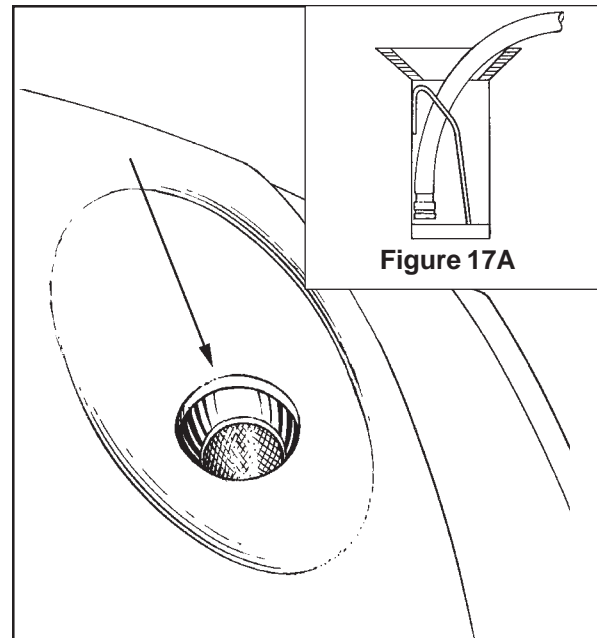

Figure 17

How To Operate The Machine

⚠ WARNING: Water solutions or cleaning materials used with this type of machine can leave wet areas on the floor surface. These areas can cause a dangerous condition for the operator or other persons. Always put CAUTION signs near the area you are cleaning.

⚠ WARNING: Machines can ignite flammable materials and vapors. Do not use with or near flammables such as gasoline, grain dust, solvents and thinners. Only use a cleaning concentration recommended by the chemical manufacturer.

⚠ WARNING: Clarke recommends a maximum water temperature of 120°F (49°C).

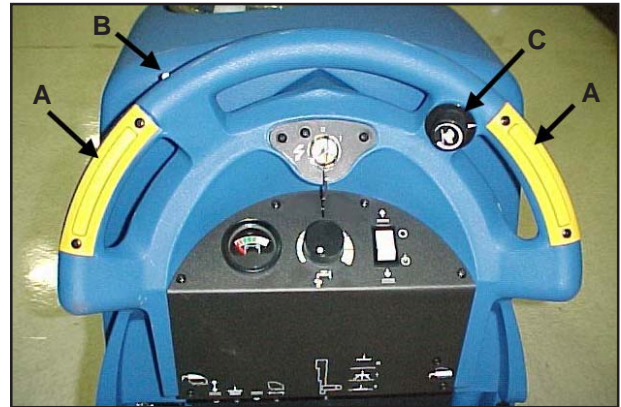

Figure 19

Operating The Machine

NOTE: Put the machine in the lowest traverse speed setting. Use the machine in an area that has no furniture or objects until you can do the following:

1. Move the machine in a straight direction, forward and backward.
2. Stop the machine safely.
3. Turn the machine both left and right and return to a straight direction.

To move the machine, follow this procedure:

1. Release the parking brake (if equipped with machine).
2. Turn the key switch to the "ON" position
3. Raise the brush.
4. Raise the squeegee.
5. When either the left or right forward/reverse switches (figure 19, item A) are pushed in, the machine will go forward.
6. Control the speed of traverse by using the traverse speed control knob (figure 19, Item C).
7. To stop, release the forward/reverse switch.
8. To reverse the machine, push in the white reverse switch (figure 19 item B) and either the right or left forward/reverse switch (figure 19 item A) at the same time.
9. To stop, release the forward/reverse switch.
10. To turn the machine, push the rear of the machine to the side.
11. When you stop the machine, turn the key switch "OFF", remove the key and set the parking brake (if equipped).

How To Operate The Machine (cont)

How To Clean A Floor

 **WARNING:** Water solutions or cleaning materials used with this type of machine can leave wet areas on the floor surfaces. These areas can cause a dangerous condition for the operator or other persons. Always put **CAUTION** signs near the area you are cleaning.

To clean a floor follow this procedure:

1. Set the parking brake (if equipped with machine.)
2. Put the water and a cleaning chemical in the clean solution tank.
3. Release the parking brake (if equipped with machine.)
4. Turn the key switch "ON".
5. Lower the squeegee.
6. Put the brush switch in the down position.
7. Turn the solution knob to the right to activate the flow of solution. Adjust the flow of clean solution to the flow desired.
8. Move the machine across the floor in the forward direction.
9. Make a 180° turn.

NOTE: When you make more passes across the floor, let the brush clean approximately 2 inches (5 cm) of the area already cleaned by the brush.

NOTE: During most cleaning procedures, apply and remove the solution in one operation.

How To Clean A Very Dirty Floor

To clean a very dirty floor, follow this procedure:

1. Apply solution to the floor.
2. Do not lower the squeegee. This will keep the vacuum motor off.
3. Lower the brush or pad and scrub the floor.
4. Scrub the floor again with additional solution and lower the squeegee.
5. Pick up all the solution with the squeegee.

Maintenance

- ⚠ WARNING:** Maintenance and repairs must be done by authorized personnel only.
- ⚠ WARNING:** Always empty the solution tank and recovery tank before doing any maintenance.
- ⚠ WARNING:** Keep all fasteners tight.

These Maintenance Procedures Must Be Done Every Day

Keep the machine clean, it will need fewer repairs and have longer life.

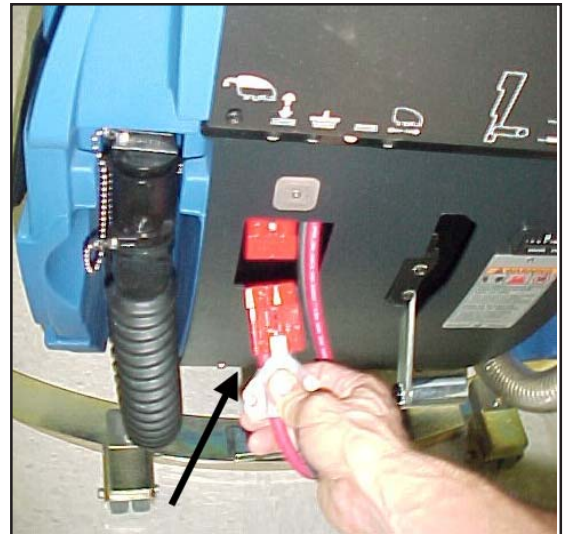

Figure 20

Do These Procedures When You Begin Your Work Period

1. Turn off key switch.
2. Disconnect AC power from battery charger (follow charger instructions).
3. Disconnect the plug on the battery charger from the battery pack connector, if using a remote charger.
4. Join the connector from the batteries to the control panel cable connection (remote charger only). See figure 20.
5. Make sure the Screen filter over the vacuum motor is clean and in position. See figure 21.
6. Make sure the recovery tank lid is on correctly. See figure 22.
7. Make sure the valve on the recovery drain hose is clean. Tightly close the valve.
8. Make sure the brush or pad is in position and installed correctly.
9. Check the installation of the squeegee and squeegee hose.
10. Make sure the solution drain/level indicator hose is secure on the storage mount on the rear of the machine.



Figure 21



Figure 22

Maintenance

Do These Procedures When You End Your Work

1. Drain the solution tank (Figure 23) and the recovery tank (Figure 24). To drain the tanks, follow this procedure:
 - a. Turn the key switch "OFF".
 - b. Remove the drain hose from the back of the machine.
 - c. Put the end of the hose over a drain or bucket.
 - d. *Recovery Tank:*
 - 1.) Turn the valve handle to the left. Pull the handle out to open the drain (Figure 25).

NOTE: Have the opening in the side of the valve away from you when you open the valve.

- 2.) To open the valve completely, turn the handle to the right. Pull the handle out of valve (Figure 26).

Solution Tank:

When hose is lowered to water level, water will flow.

2. Flush the tanks. To flush the tanks, put clean water in the tank through the opening on top of the tank.
3. If a tank or drain hose has an obstruction, use a pressure water hose to flush the tank or hose. Put the water hose into the drain hose.
4. Leave the tanks and the recovery drain valve open to dry in the air.
5. Check the squeegee blade. Use a cloth to clean the squeegee blade. If the squeegee blade is damaged or worn, turn or replace the blade.
6. Check and clean the solution lid gasket. Use a mild cleaning solution and rinse the parts in clean water.

Check the batteries and if necessary add distilled water after charging. The correct level is within 1/4 inch (1/2 cm) of the bottom of the tube in each cell.

CAUTION: Tap water may contain contaminants that will damage batteries. Batteries must be refilled with **DISTILLED WATER ONLY**.

WARNING: Lead acid batteries generate gases which can cause an explosion. **NO SMOKING.** Always wear eye protection and protective clothing when working near batteries.

Use a clean cloth and wipe the surface of the machine.

Charge the batteries. See the instruction in the section of this book called "How To Charge The Batteries".



Figure 23



Figure 24

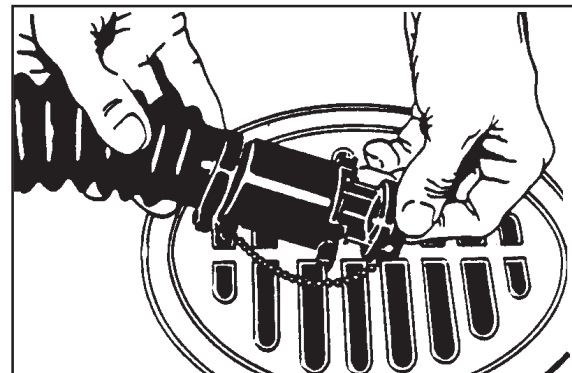

Figure 25

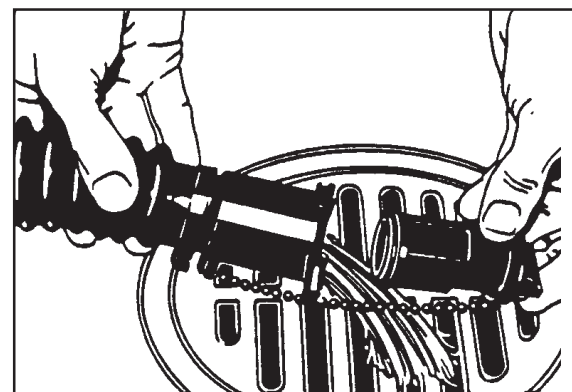

Figure 26

Maintenance

Maintenance Procedures To Be Done Every Week:

⚠ WARNING: Maintenance and repairs must be done by authorized personnel only. Always empty the solution tank and the recovery tank before doing any maintenance. Keep all fasteners tight.

⚠ WARNING: Always wear eye protection and protective clothing when working near batteries. Do not put tools or other metal objects across the battery terminals or the tops of the batteries.

⚠ CAUTION: To prevent damage to the machine, and discharge across the tops of the batteries, do not fill the batteries above the bottom of the tube in each cell. Wipe any acid from the machine or the tops of the batteries. Do not add acid to battery after installation.

NOTE: Always turn off key switch before servicing the machine.

⚠ WARNING: Always wear eye protection and protective clothing when working near batteries. **NO SMOKING!**

1. To inspect batteries, tip up recovery tank until it locks in the full open position. See figure 27A. To close the tank, pull up on the latch arm and then slowly lower the tank to the closed position.

⚠ CAUTION: Before raising the tank, be sure tank is empty.

NOTE: There is an intermediate position available for holding the recovery tank open for charging batteries. See figure 27B.

⚠ WARNING: Do not operate or perform maintenance on the machine while the recovery tank is in the intermediate position. The tank can be accidentally bumped and it may slam shut.

2. Disconnect the batteries. Use a cloth and a solution of ammonia or bicarbonate of soda to wipe the top of the batteries. Clean the battery terminals. Reconnect the batteries.
3. Check the hoses for leaks, obstructions and other damage.
4. Use a grease gun to lubricate the dual casters. See figure 28.



Figure 27A



Figure 27B

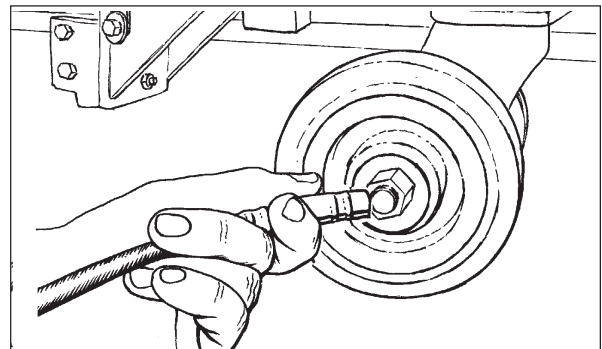

Figure 28

Maintenance

Maintenance For The Squeegee

To remove the squeegee, follow this procedure:

1. Remove the squeegee assembly by loosening the two knobs that attach the squeegee to the machine. Pull the squeegee assembly off. See figure 29.
2. Inspect the squeegee blade.
3. If the blade is worn, turn the blade so that a new edge is in the wiping position.
4. Reinstall squeegee assembly on the machine.

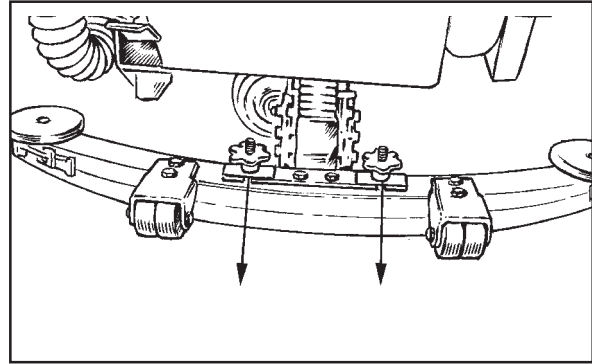

Figure 29

How To Adjust The Squeegee

The following adjustments are set at the factory, however they may require slight adjustment.

Adjusting Squeegee Tilt:

The tilt of the squeegee causes the rear blade to raise up in the center or on the ends, depending on which direction the tilt is changed. For tilt adjustment, refer to figure 30. Loosen left and right screw "X". In order to bring the blades down in the center, tip "Y" down. To bring both ends down, tip "Y" up. Make very small adjustments and try it until a uniform flare is achieved.

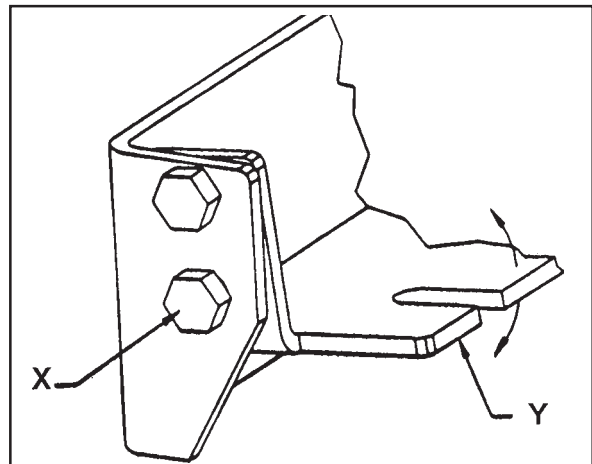

Figure 30

Adjusting Squeegee Blades:

When properly installed the front blade should be approximately 0.06" (1.5mm) above the rear blade. See figure 31.

⚠ WARNING: Maintenance and repairs must be done by authorized personnel only .

⚠ WARNING: Electrical repairs must be done by authorized personnel only.

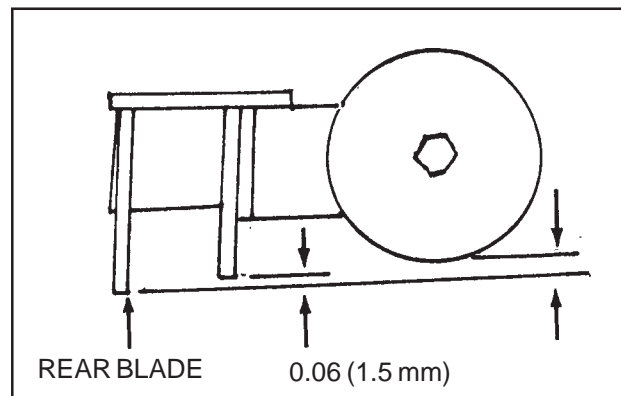

Figure 31

Maintenance cont.

Consult your Clarke Authorized Service Person to do the service procedures.

Use only genuine Clarke parts.

How to Center or Offset the Brush Head

The brush head on this machine can be centered or offset 1 inch to the right side of the machine. To center or offset the brush head, follow this procedure:

Recommended tools: 3/8" drive ratchet, 3" extension and 9/16" socket.

CAUTION: Before offsetting the brush head, be sure that the recovery tank is empty of solution.

1. Turn the key switch "ON".
2. Put the brush switch to the "Up" position.
3. Turn the key switch "OFF" and remove the key.
4. Tip up the recovery tank until it locks in the full open position.
5. Go to the front of the machine and unlatch the front cover and swing cover open.
6. Locate the four mounting studs on the brush head bracket. See figure 32. The top two mounting nuts can be accessed through the top of the solution tank. The lower two can be accessed through the front. Loosen the four mounting nuts 2 to 3 turns counterclockwise. NOTE: Do not remove mounting nuts.
7. The brush head assembly can slide to the right side by one inch or placed back into the center. Slide the brush head assembly all the way to the ends of the slots for the desired position. This insures that the head operates straight up and down.
8. After repositioning the brush head, tighten nuts securely to approximately 236 inch-lbs.
9. Close the front cover.
10. Close the recovery tank.

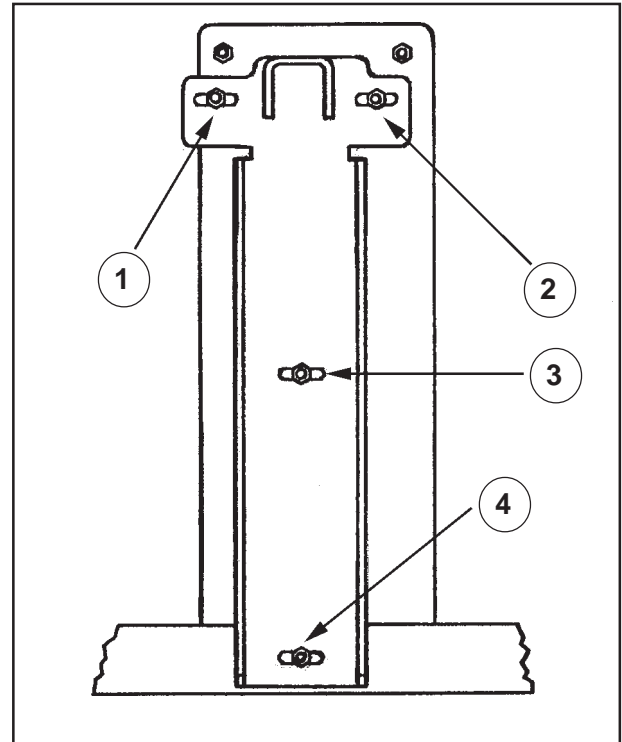

Figure 32

Accessories

ACCESSORIES

<u>Description</u>	<u>Part No.</u>
Power Wand System Kit	10150A
Clarke Care Kit	14607A
39" Squeegee Assembly	11054K
Poly Dur Protectant	50478A
Kit, Grease Gun	55420A
Kit, Low Voltage Shut-Off	14097A
Brake Kit Assembly	10072A
Accessory Bag	30070A
Hour Meter Kit	10656A
Soft Caster Assembly	51092A
Kit, Solution Fill	10177A
ESP Recycle System	10663A

Brushes and Pads:

<u>Size</u>	<u>Description</u>	<u>Part No.</u>
14 x 28	Red (5 pack)	997001
14 x 28	Black (5 pack)	997000
14 x 28	White (5 pack)	997002
14 x 28	Blue (5 pack)	997006

Squeegee Blades:

<u>Description</u>	<u>39" Assembly</u>
Blade, Rear - Gum Rubber	30069A
Blade, Rear - Nitrile Solid	30082A
Blade, Rear - Ribbed Orange	30086A
Blade, Front - Ribbed Natural	30091A
Blade, Front - Slit Grout	30080A
Blade, Front - Ribbed Orange	30084A

HOW TO CORRECT PROBLEMS IN THE MACHINE

PROBLEM	CAUSE	ACTION
There is no solution flow.	<p>The solution tank is empty.</p> <p>The solution valve is closed.</p> <p>There is an obstruction in the solution hose or filter.</p> <p>The solution valve or electric wiring is damaged.</p> <p>The solution module is defective.</p>	<p>Fill the solution tank.</p> <p>Open the solution valve.</p> <p>Remove the obstruction from the hose or filter.</p> <p>Repair or replace the valve or the electric wiring.</p> <p>Replace solution module</p>
The solution flow does not stop.	<p>The solution valve is open.</p> <p>The solution valve or wiring is damaged.</p> <p>The solution valve is dirty</p> <p>There is a damaged seat and washer in the solution valve.</p> <p>The solution module is defective.</p>	<p>Close or Clean the solution valve.</p> <p>Repair or replace the valve and the wiring.</p> <p>Clean the solution valve.</p> <p>Replace the seat and washer.</p> <p>Replace solution module.</p>
The machine does not remove all the water from the floor.	<p>The squeegee is up.</p> <p>The squeegee tilt is not correct.</p> <p>The recovery tank is full.</p> <p>The screen filter is dirty.</p> <p>There is an obstruction or damage in the squeegee, squeegee hose or standpipe.</p> <p>The vacuum motor is not running.</p> <p>The squeegee hose is disconnected, or damaged</p> <p>The squeegee blade is damaged, worn, or incorrectly installed.</p> <p>The gaskets on the cover of the recovery tank are damaged.</p>	<p>Lower the squeegee.</p> <p>To adjust See Figure 11, page 23.</p> <p>Drain the recovery tank.</p> <p>Clean the screen filter.</p> <p>Remove the obstruction or repair the damage.</p> <p>Check for tripped breaker. Have an authorized service person make repairs.</p> <p>Check and connect hose.</p> <p>Turn or replace the squeegee blade. Correctly install the squeegee blade.</p> <p>Replace the gaskets.</p>
The batteries do not give the normal running time.	<p>The battery terminals are dirty or damaged.</p> <p>The electrolyte level is too low.</p> <p>The batteries are not fully charged.</p> <p>The charger is damaged.</p> <p>The battery is defective.</p> <p>The batteries are disconnected.</p> <p>Brush is in heavy scrub setting.</p>	<p>Clean the terminals and connectors. Replace the damaged cables. Charge the batteries.</p> <p>Add distilled water to each cell and charge the batteries.</p> <p>Charge the batteries for a full 16 hour charge.</p> <p>Have an authorized service person repair the charger.</p> <p>Check voltage of each cell while discharging.</p> <p>Connect the batteries.</p> <p>Adjust Pressure.</p>

PROBLEM	CAUSE	ACTION
<p>The cleaning is not even.</p>	<p>The scrub brush or pad is worn.</p> <p>There is damage to the brush assembly, caster or the solution valve.</p> <p>The brush motor is not running</p> <p>The solution level is low.</p>	<p>Replace the scrub brush or pad.</p> <p>Have an authorized service person make the needed repairs.</p> <p>Check for tripped breaker. Reset. Check for loose connections.</p> <p>Fill the solution tank.</p> <p>NOTE: If the problem continues consult an authorized service person.</p>
<p>The machine does not run.</p>	<p>The machine loses power.</p> <p>Key or switch is off.</p> <p>Batteries are unplugged. Battery terminals are dirty.</p> <p>Batteries are discharged</p>	<p>Reset the circuit breaker.</p> <p>Turn key or switch on.</p> <p>Check the battery connections.</p> <p>Check battery gauge and recharge</p> <p>NOTE: If the problem continues consult an authorized service person.</p>

Clarke[®]

BOOST[™] 28

Section II

Parts and Service Manual

(71071A)

U.S. Patent No. 6,105,192; No. 6,557,207; No. 6,760,947; No. 5,383,251; and patents pending.

Clarke®
BOOST™ 28
Final Assembly Drawing 9/05

On-Board Charger Option

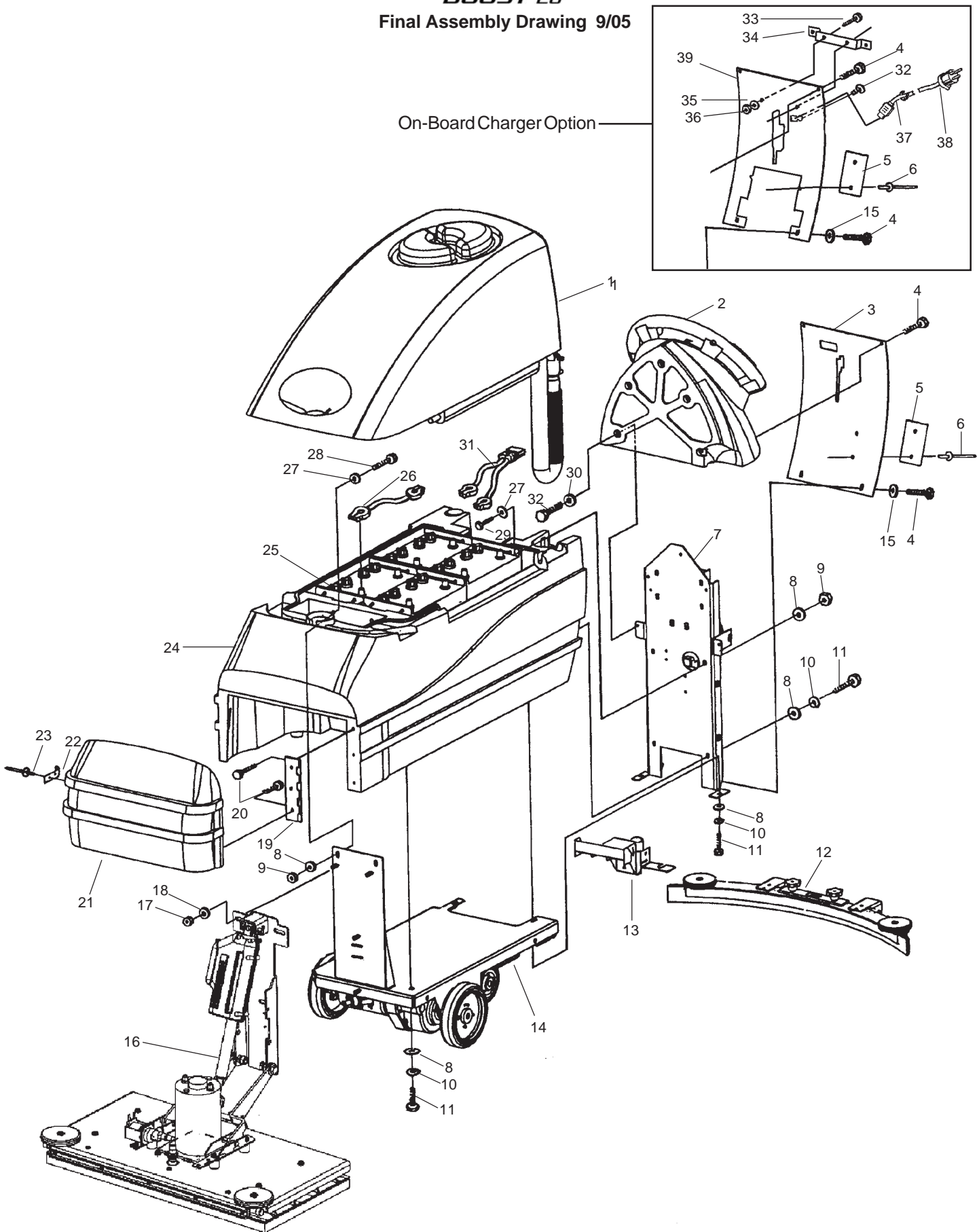

Clarke®
BOOST™ 28

Final Assembly Parts List 9/05

Ref. #	Part No.	Description	Charger	
			Remote	On-Board
			Qty	Qty
1	Ref	Assembly, Recovery Tank	Ref	Ref
2	Ref	Assembly, Control Panel	Ref	Ref
3	30064A	Rear Cover	1	-
4	80108A	Screw, 10-24 x 1/2 SS	4	4
5	70080A	Plate, Warning	1	1
6	83010A	Rivet, Pop 1/8	2	2
7	Ref	Assembly, Rear Panel	Ref	Ref
8	980651	Washer, 5/16 Flat	11	11
9	920110	Nut, 5/16 -18 ESNA	4	4
10	980652	Washer, 5/16 Lock	7	7
11	85811A	Screw, 5/16 -18 x 3/4	7	7
12	See pg	Assembly, Squeegee 32"	Ref	Ref
13	See pg	Assembly, Squeegee Lift	Ref	Ref
14	See pg	Assembly, Traverse System	Ref	Ref
15	980982	Washer #10	2	2
16	Ref	Assembly, Brush Head	Ref	Ref
17	81105A	Nut, 3/8-16 ESNA	4	4
18	87031A	Washer, 3/8 Flat SS	4	4
19	50965A	Hinge	1	1
20	85395A	Screw, 1/4-20 x 1/2 SS	6	6
21	30249R	Front Cover	1	1
22	50966A	Latch, Front Cover	Ref	Ref
23	930090	Rivet, 5/32 x 9/16	2	2
24	Ref	Assembly, Solution Tank	Ref	Ref
25*	40136A	Battery 6V, 250 AH (wet - Stud Post)	4	4
	40137A	Battery 6V, 250 AH (dry - Stud Post)	4	4
	891384	Battery, 6V 330 AH (wet - UT Post)	4	4
	891385	Battery, 6V 330 AH (dry - UT Post)	4	4
26	41206A	Series Battery Cable (Taper Style)	3	3
	41217A	Series Battery Cable (Ring Style)	3	3
27	980205	Washer, 5/16 Fender	4	4
28	85734A	Screw, 5/16-18 x 2	2	2
29	85739A	Screw, 5/16-18 x 3 Hex	2	2
30	87026A	Washer, 1/4 flat SS	5	5
31	41211A	Battery, Cable (Taper Style)	1	1
	40174A	Battery, Cable (Ring Style)	1	1
32	85518A	Screw, 1/4-20 x 3/4	5	6
33	85391A	Screw, 1/4-20 x 5/8	-	2
34	61780A	Bracket, Cord Wrap	-	1
35	87007A	Washer, 1/4 Flat	-	2
36	81217A	Nut, 1/4-20	-	2
37	53851A	Bushing	-	1
38	40740A	Cord, Power	-	1
39	30640A	Rear Cover	-	1
NI	40512A	Battery charger	1	-
NI	77092A	Label, Gases	1	1
NI	77093A	Label, Falling	1	1
NI	70226A	Label, Battery	1	1
NI	10072A	Parking Brake Assembly	1	1

* See page 12 for installation.

Clarke®
BOOST™ 28
Recovery Tank Assembly Drawing 9/05

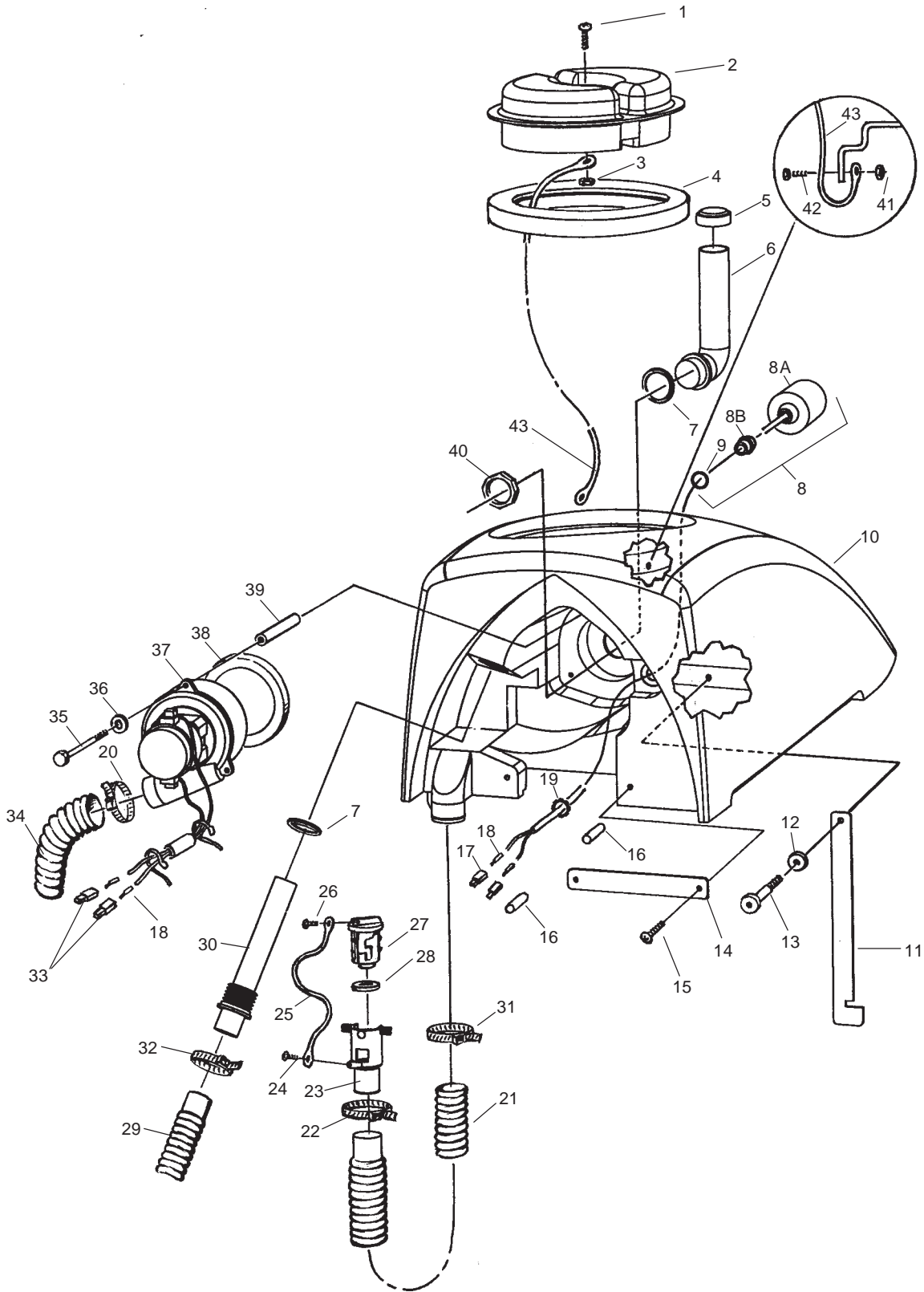

#40 Recommended Torque
175 + or - 5 inch pounds

Clarke®
BOOST™ 28
Recovery Tank Assembly Parts List 9/05

Ref. #	Part No.	Description	Qty
1	962798	Screw, 10-24 x .5	1
2	30057A	Lid	1
3	81110A	Nut, 10-24 SS	1
4	30065A	Gasket, Lid	1
5	58069A	Strainer	1
6	39338A	Stand Tube	1
7	837304	O-Ring	2
8	10660A	Switch Kit, (Includes 8A, 8B, 9)	1
8A	40002A	Switch (included in Item 8)	1
8B	56459A	Relief, Strain (included in Item 8A)	1
9	59877A	Seal, Washer	1
10	30248A	Tank, Recovery	1
11	60373A	Latch, Recovery Tank	1
12	87622A	Washer, Nylon 5/16 x 5/8 x 1/32	1
13	80043A	Screw, .25 x 20 x .25, Shoulder	1
14	60336A	Strap, Hose Retainer	1
15	85100A	Screw, 10-32 x 1/2 SS Xylan Coating	2
16	30068A	Hinge, Pin (included w/ item 10)	2
17	43402A	Housing, Connector(included in 8A)	2
18	41809A	Contact (included in 8A)	4
19	82100A	Nut, Strain Relief Lock	1
20	872010	Clamp, Hose	1
21	35165A	Hose, Drain	1
22	832002	Clamp, Hose	1
23	839401	Valve, Drain	1
24	962943	Screw, 8-18 x 1/2 PN	1
25	52206A	Chain	1
26	962987	Screw, 10-24 x 3/8 Pan	1
27	833901	Drain, Valve Handle	1
28	833407	Gasket, Drain Valve	1
29	51060A	Hose, Squeegee	1
30	830208	Squeegee Stand Tube	1
31	80110A	Hose Clamp	1
32	752020	Hose Clamp	1
33	43401A	Housing, Vac Motor Connector	2
34	674110	Hose	1
35	85728A	Screw, 1/4-20 x 4 Hex	3
36	87026A	Washer, 1/4 Flat	3
37	51049A	Motor, Vacuum (3-Stage)	1
	51050A	Motor, Vacuum, (2-Stage Option)	1
38	643418	Gasket	1
39	58533A	Spacer	3
40	920797	Nut	1
41	962666	Screw, 10-24 x 3/4	1
42	920296	Nut, 10-24 Elastic	1
43	38020A	Strap	1
NI	839410	Valve Asm. (includes 23, 24, 25, 26, 27, 28)	1
NI	70226A	Label, Battery Installation	1

Clarke®
BOOST™ 28
Solution Tank Assembly 9/05

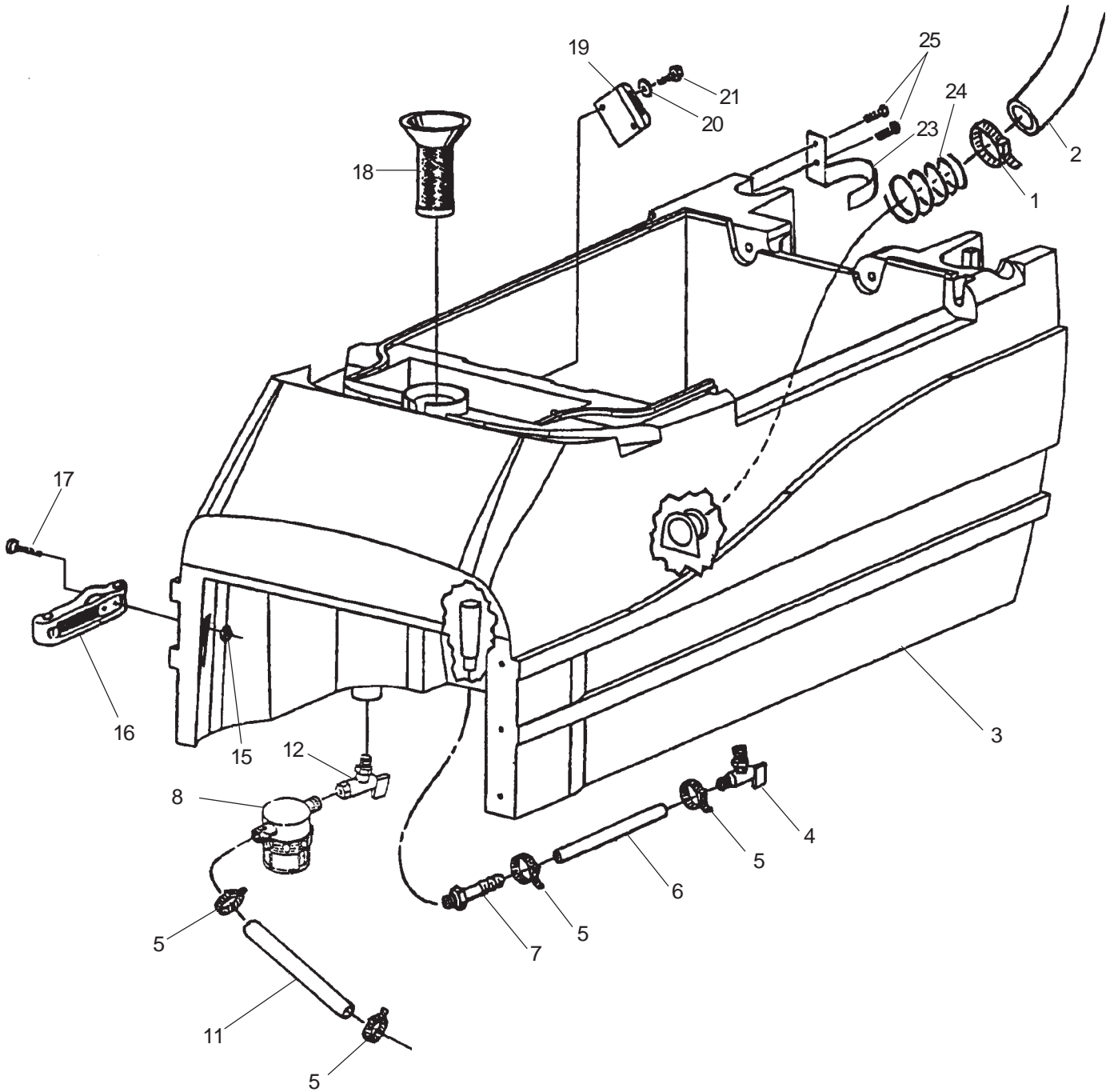

Solution Tank Assembly Parts List 9/05

Ref. #	Part No.	Description	Qty
1	872010	Clamp, Hose	1
2	50964A	Hose, Drain	1
3	30244A	Tank, Solution	1
4	59614A	Valve, Battery Drain	1
5		Hose Clamp	
6	30453A	Hose, Clear Vinyl	1
7	820207	Adapter, Hose 3/8 MPT x 1/2 Hosebarb	1
8	53562A	Filter, Bowl Asm	1
11	30446A	Hose	1
12	51204A	Valve, 3/8 NPT Shut Off	Pg. 46
13	59789A	Valve, Electric	1
15	81109A	Nut, 8-32 ESNA SS	1
16	50966A	Latch	1
17	80105A	Screw, 8-32 x 1 1/4 SS	2
18	50963B	Screen, Fill (with hose retention)	1
	51308B	Strainer (without hose retention)	1
19	69879A	Bracket, Latch	1
20	170892	Washer, Lock 1/4	2
21	170915	Screw, 1/4-20 x 3/4 SS Hex	2
23	60480A	Bracket, Hose	1
24	51346A	Spring, Hose	1
25	80108A	Screw, 10-24 x 1/2	2
NI	30162A	Funnel (included w/Kit 10177A)	1
NI	10177A	Kit, Solution Fill	1

(includes #18-51308A)(includes NI - 30162A)

53562A Components		
Clarke P/N	Description	Qty.
50081A	Bowl, Filter	1
53563A	Filter, Screen	1
53564A	Upper Body	1
54369A	Gasket, Bowl	1

Clarke®
BOOST™ 28
Rear Panel Assembly Drawing 9/05
Remote Charger

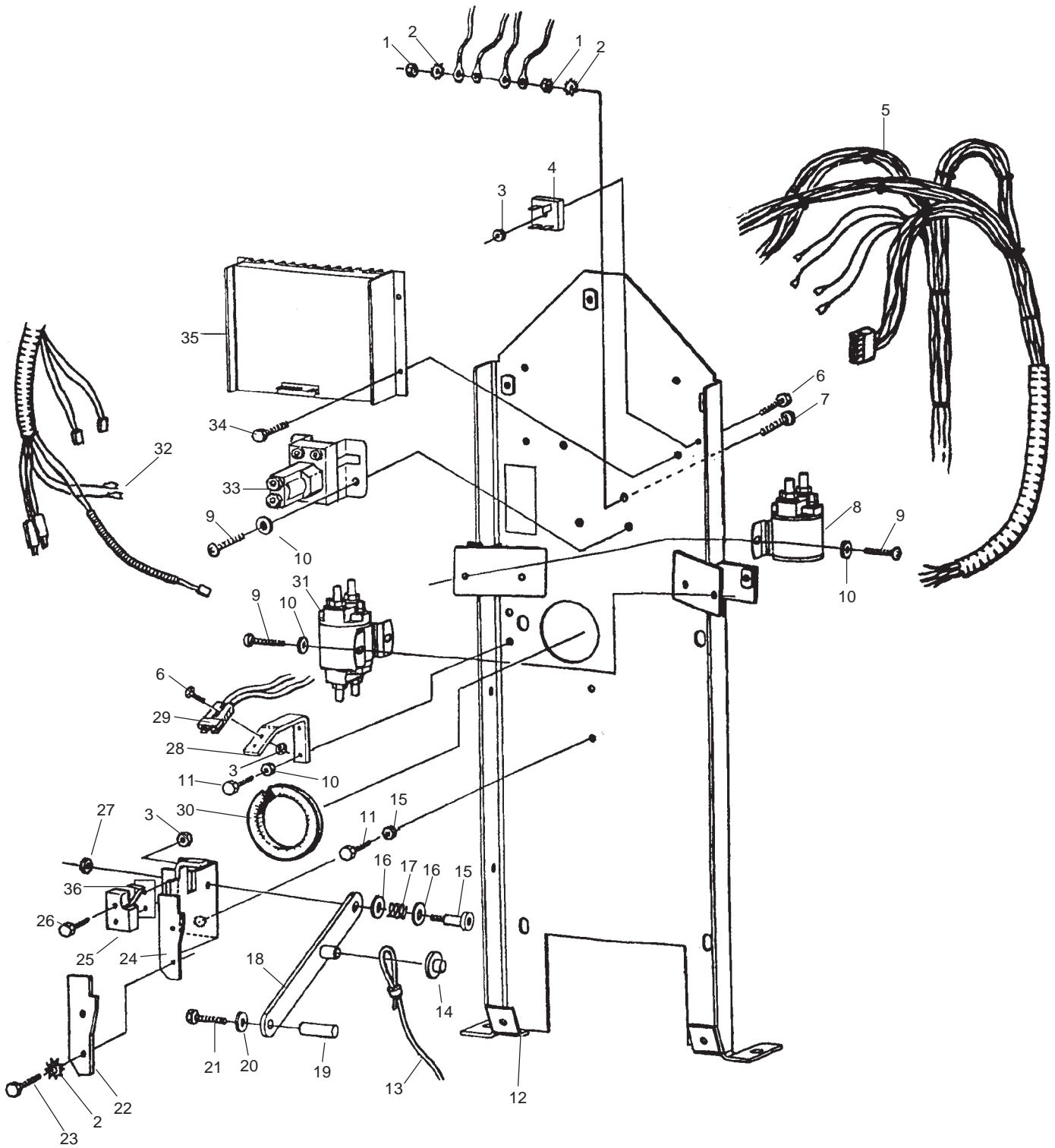

Clarke®
BOOST™ 28
Rear Panel Assembly Parts List 9/05
Remote Charger

Ref. #	Part No.	Description	Qty
1	920224	Nut, 10-32	2
2	980603	Washer, Starlock	4
3	920056	Nut, 6-32	5
4	46106A	Rectifier	1
5	40863A	Harness, Power "L"	1
6	962212	Screw, 6-32 x 7/8	3
7	85383A	Screw, 10-32 x 3/4	1
8	41810A	Solenoid, Brush	1
9	85395A	Screw, 1/4-20 x 1/2	6
10	980614	Washer, Starlock, 1/4	10
11	85391A	Screw, 1/4-20 x 5/8	4
12	60261A	Panel, Rear Metal	1
13	60257A	Cable, Squeegee Lift	1
14	920346	Nut, Pal	1
15	80028A	Bolt, Shoulder, 5/16 x 1.0	1
16	980692	Washer, Flat 5/16 SS	2
17	438360	Spring	1
18	64901A	Lever, Squeegee Lift	1
19	64490A	Handle, Squeegee	1
20	980666	Washer, 3/8 Starlock	1
21	85389A	Screw, 3/8-16 x 5/8	1
22	68643A	Plate, Vacuum Wear	1
23	962968	Screw, 10-24 x 1/2	2
24	61260A	Plate, Squeegee Lift	1
25	47388A	Switch, Vacuum Lever	1
26	85601A	Screw, 6-32 x 1 1/4 PN	2
27	81217A	Nut, 1/4-20 x .218H Nylock	1
28	60264A	Bracket, Power Connector	1
29	41146A	Cable, Assembly Console	1
30	193951	Grommet, slotted, 8"	Ref
31	41811A	Solenoid, Main	1
32	40157A	Harness, Traverse	1
33	40169A	Solenoid, Vacuum	1
34	962798	Screw, 10-24 x 1/2	2
35	40132A	Control, Traverse	1
36	30097A	Insulator, Mylar	1
NI	77093A	Label, Falling Parts	1
NI	77092A	Label, Gases	1

Clarke®
BOOST™ 28
 Rear Panel Assembly Drawing 9/05
 On-Board Charger

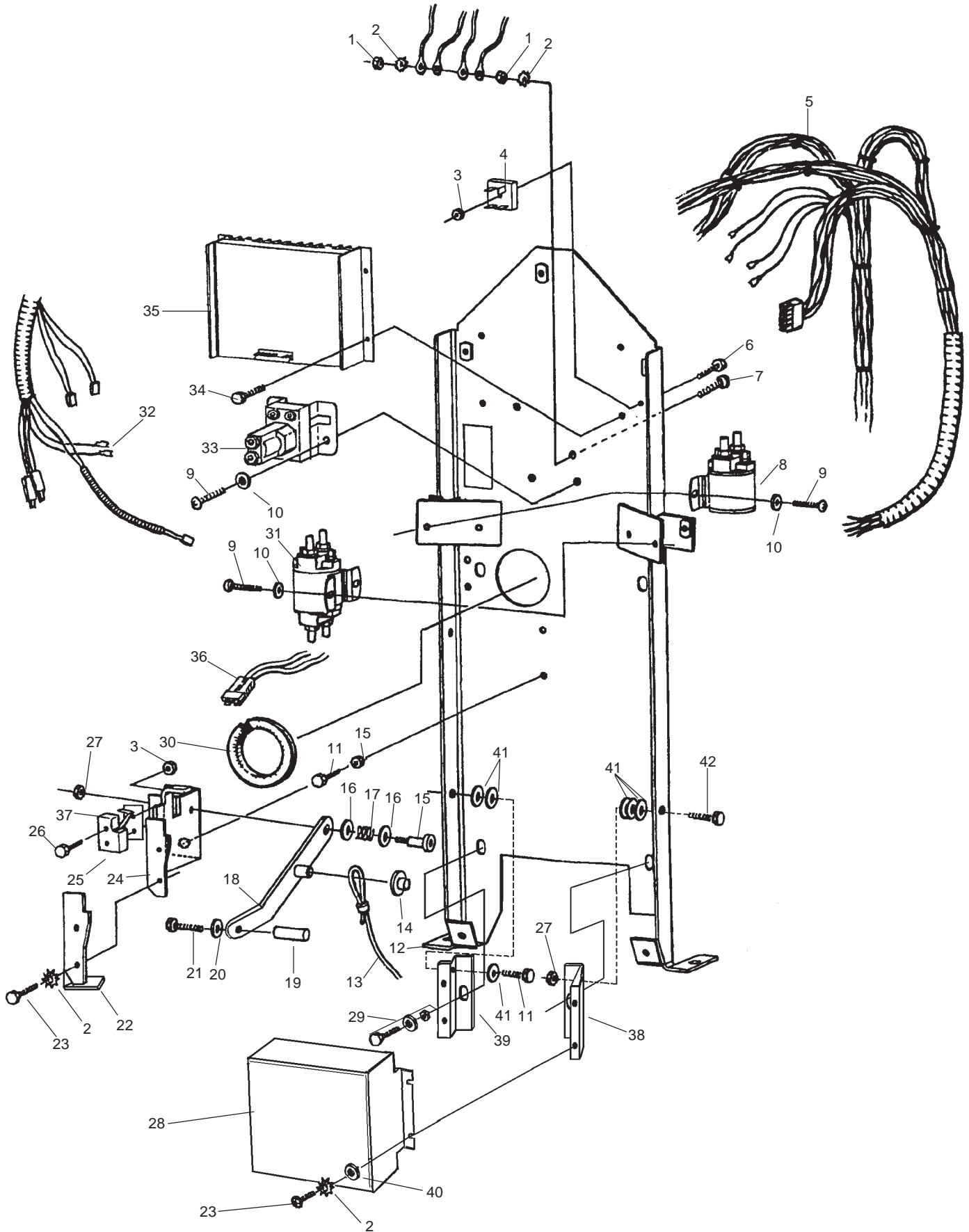

Clarke®
BOOST™ 28

Rear Panel Assembly Parts List 9/05
On-Board Charger

Ref. #	Part No.	Description	Qty
1	920224	Nut, 10-32	2
2	980603	Washer, Starlock	4
3	920056	Nut, 6-32	2
4	46106A	Rectifier	1
5	40863A	Harness, Power	1
6	962212	Screw, 6-32 x 7/8	3
7	85383A	Screw, 10-32 x 3/4	1
8	41810A	Solenoid, Brush	1
9	85395A	Screw, 1/4-20 x 1/2	6
10	980614	Washer, Starlock, 1/4	10
11	85391A	Screw, 1/4-20 x 5/8	5
12	60261A	Panel, Rear Metal	1
13	60257A	Cable, Squeegee Lift	1
14	920346	Nut, Pal	1
15	80028A	Bolt, Shoulder, 5/16 x 1.0	1
16	980692	Washer, Flat 5/16 SS	2
17	438360	Spring	1
18	61779A	Lever, Squeegee Lift	1
19	64490A	Handle, Squeegee	1
20	980666	Washer, 3/8 Starlock	1
21	85389A	Screw, 3/8-16 x 5/8	1
22	61781A	Plate, Vacuum Wear	1
23	962968	Screw, 10-24 x 1/2	6
24	61260A	Plate, Squeegee Lift	1
25	47388A	Switch, Vacuum Lever	1
26	85601A	Screw, 6-32 x 1 1/4 PN	2
27	81217A	Nut, 1/4-20 x .218H Nylock	2
28	40844A	Charger, 24V	1
29			
30	193951	Grommet, slotted, 8"	Ref
31	41811A	Solenoid, Main	1
32	40157A	Harness, Traverse	1
33	40169A	Solenoid, Vacuum	1
34	962798	Screw, 10-24 x 1/2	2
35	40132A	Control, Traverse	1
36	40779A	Cable, Battery Console	1
37	30097A	Insulator, Mylar	1
38	61778A	Bracket, Right Hand Charger Mount	1
39	61777A	Bracket, Left Hand Charger Mount	1
40	980982	Washer, #10	4
41	87007A	Washer, Flat 1/4"	6
42	85390A	Screw, 1/4 - 20 x 1 1/4	1
NI	77093A	Label, Falling Parts	1
NI	77092A	Label, Gases	1

Clarke®
BOOST™ 28

Control Panel Assembly Drawing 9/05

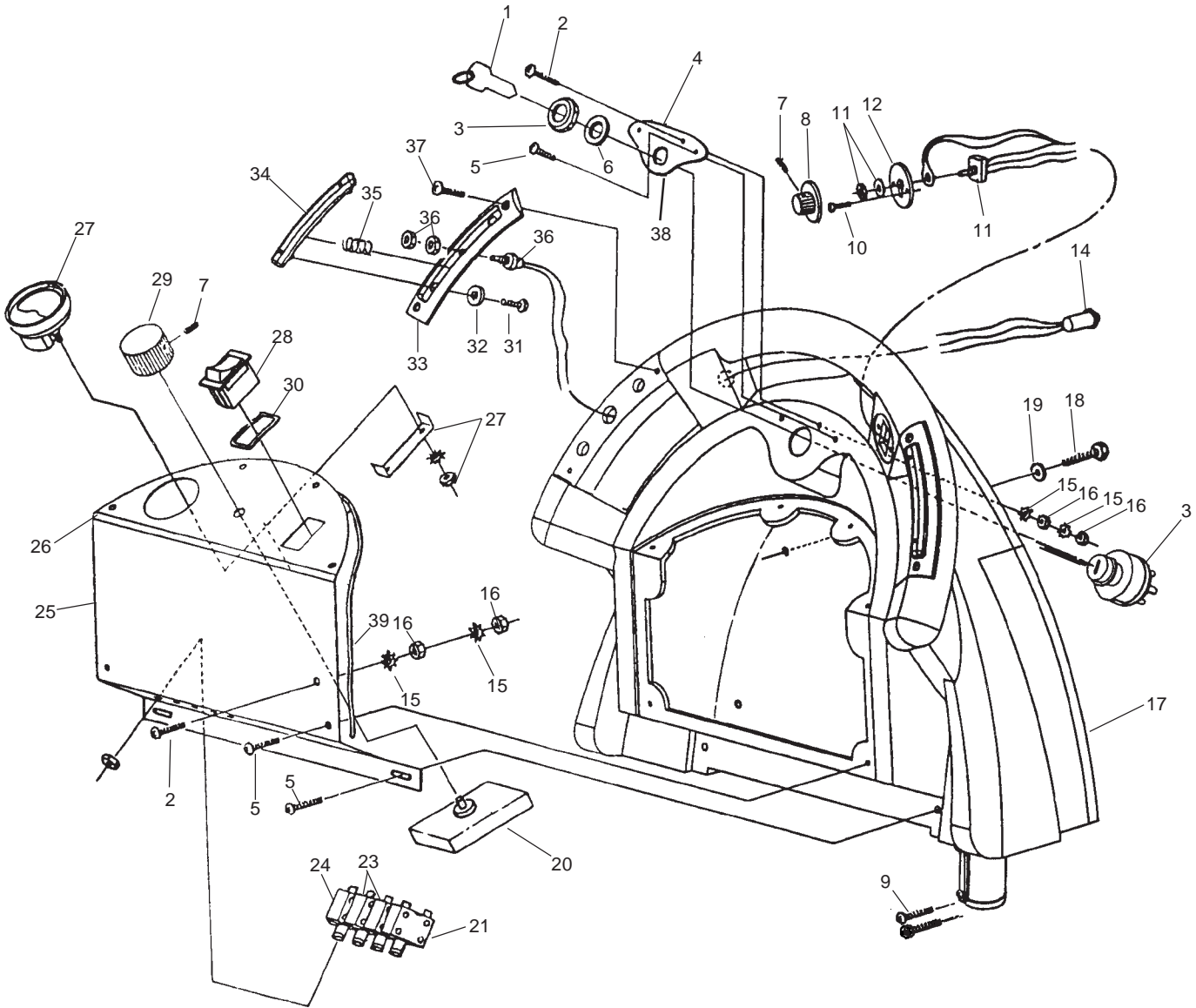

Clarke®
BOOST™ 28

Control Panel Assembly Parts List 9/05

Ref. #	Part No.	Description	Qty
1	55413A	Key (included w/Item 3)	Ref
2	84237A	Screw, 10-32 x ½	2
3	47380A	Switch, Key	1
4	60334A	Panel, Key Switch	1
5	80108A	Screw, 10-24 x ½ SS Black Xylan	8
6	87052A	Washer, Switch	1
7	962262	Screw, Set 8-32 x ½ (included in item 29)	4
8	50962A	Traverse, Control Knob	1
9	85703A	Screw, 10-00 x ½ PN	1
10	962957	Screw, 10-16	2
11	40135A	Harness, Potentiometer Assembly.	1
12	60259A	Bracket, Traverse Switch	1
13	980666	Washer, 3/8 Starlock	1
14	40158A	Switch, Reverse	1
15	980603	Washer	4
16	920224	Nut, 10-32 Hex	4
17	30072A	Control Handle	-
18	85391A	Screw, ¼-20 x ½ SS	Ref
19	87026A	Washer, ¼ SS	Ref
20	40858A	Control, Solution	1
21	41422A	Breaker, Circuit 25 Amp Traverse	1
23	41448A	Breaker, Circuit 30 Amp Vac/Brush	2
24	41423A	Breaker, Circuit 5 Amp Actuator	1
25	71078A	Label, control	1
26	61812A	Panel, Control, Metal	1
27	40217B	Meter, Battery	1
28	47381B	Switch, Brush Adjustment	1
29	55502A	Knob	1
30	30096A	Gasket, Switch	1
31	962330	Screw, 6-32 x ³⁄₈	4
32	980608	Washer	4
33	30056A	Housing, Switch & Lever	2
34	30055A	Lever, Switch	2
35	50961A	Spring, Switch	4
36	40126A	Switch, Forward/Reverse	2
37	80104A	Screw, 10-32 x ½ SS Black Xylan	4
38	70219A	Label, Key Switch	1
39	34264A	Gasket, Panel	1
NI	47708A	¼ F.I.M.Q.D.	4
NI	47712A	¼ F.I.F.Q.D.	1

Clarke®
BOOST™ 28
Squeegee Lift Assembly Drawing 9/05

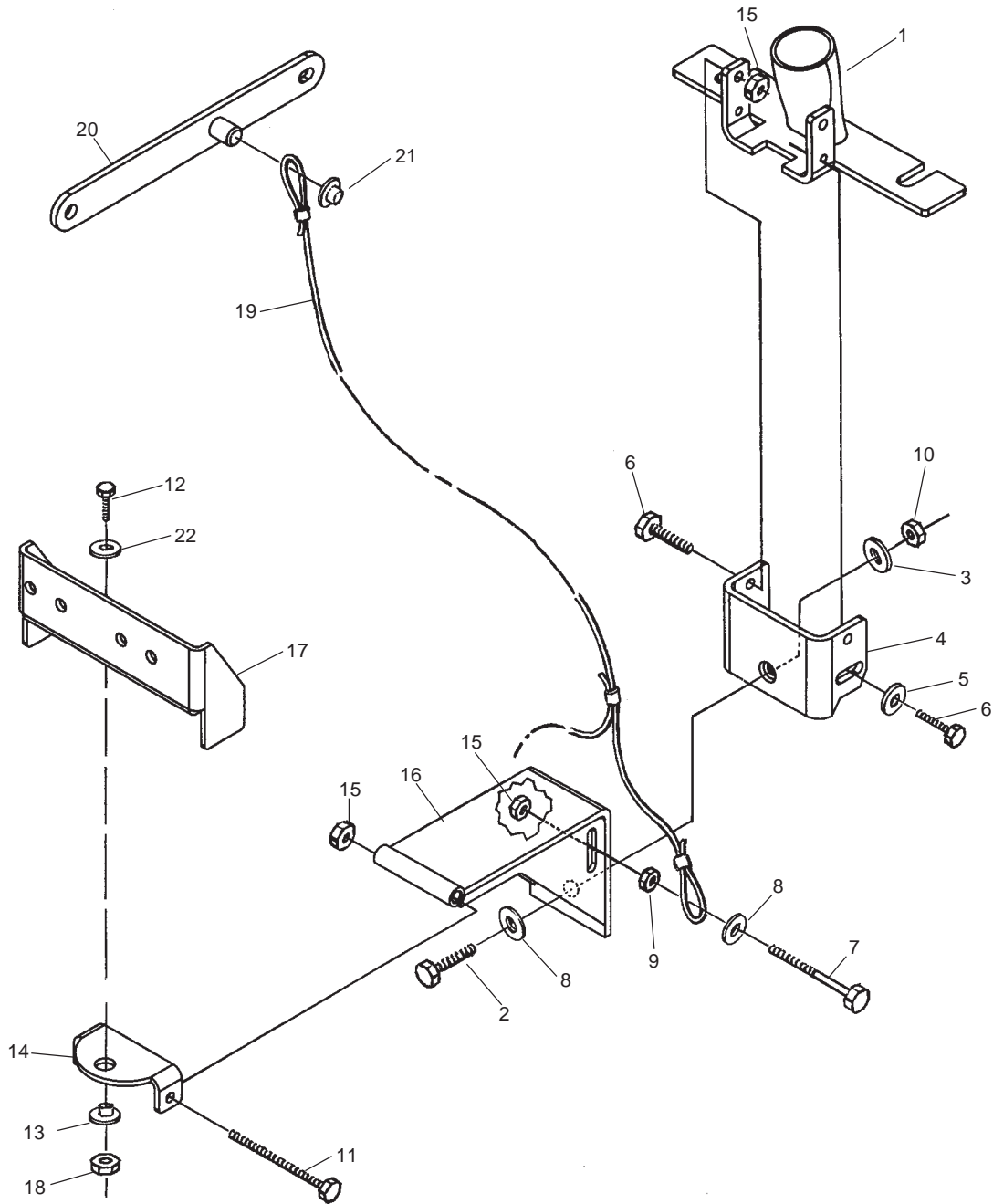

Clarke®
BOOST™ 28

Squeegee Lift Assembly Parts List 9/05

Ref. #	Part No.	Description	Qty
1	61263A	Bracket Tube	1
2	85730A	Screw, 3/8-16 x 1¼, Hex SS	1
3	980638	Lockwasher, 3/8 LT Spring Type	1
4	69860B	Bracket, Pin	1
5	87026A	Washer, ¼ SS	2
6	170915	Screw, ¼-20 x ¾	4
7	962481	Screw, ¼-20 x 1¼ Hex	2
8	87031A	Washer, 3/8 Flat	3
9	920208	Nut, ¼-20	2
10	81111A	Nut, 3/8-16 ESNA	1
11	80101A	Screw, ¼-20 x 3¼ SS	1
12	85811A	Screw, 5/16-18 x ¾	1
13	67867A	Nut, spacer	1
14	60256A	Squeegee, Pivot Arm	1
15	81104A	Nut, ¼ Nylock	5
16	60255A	Bracket, Squeegee	1
17	60328A	Mount, Squeegee	1
18	81112A	Nut, 5/16-18 Thin ESNA SS	1
19	Page 35	Cable, Squeegee Lift	Ref
20	Page 35	Lift Handle Assembly	Ref
21	920346	Palnut	Ref
22	980651	Washer	1

Clarke®
BOOST™ 28
Squeegee Assembly Drawing 9/05

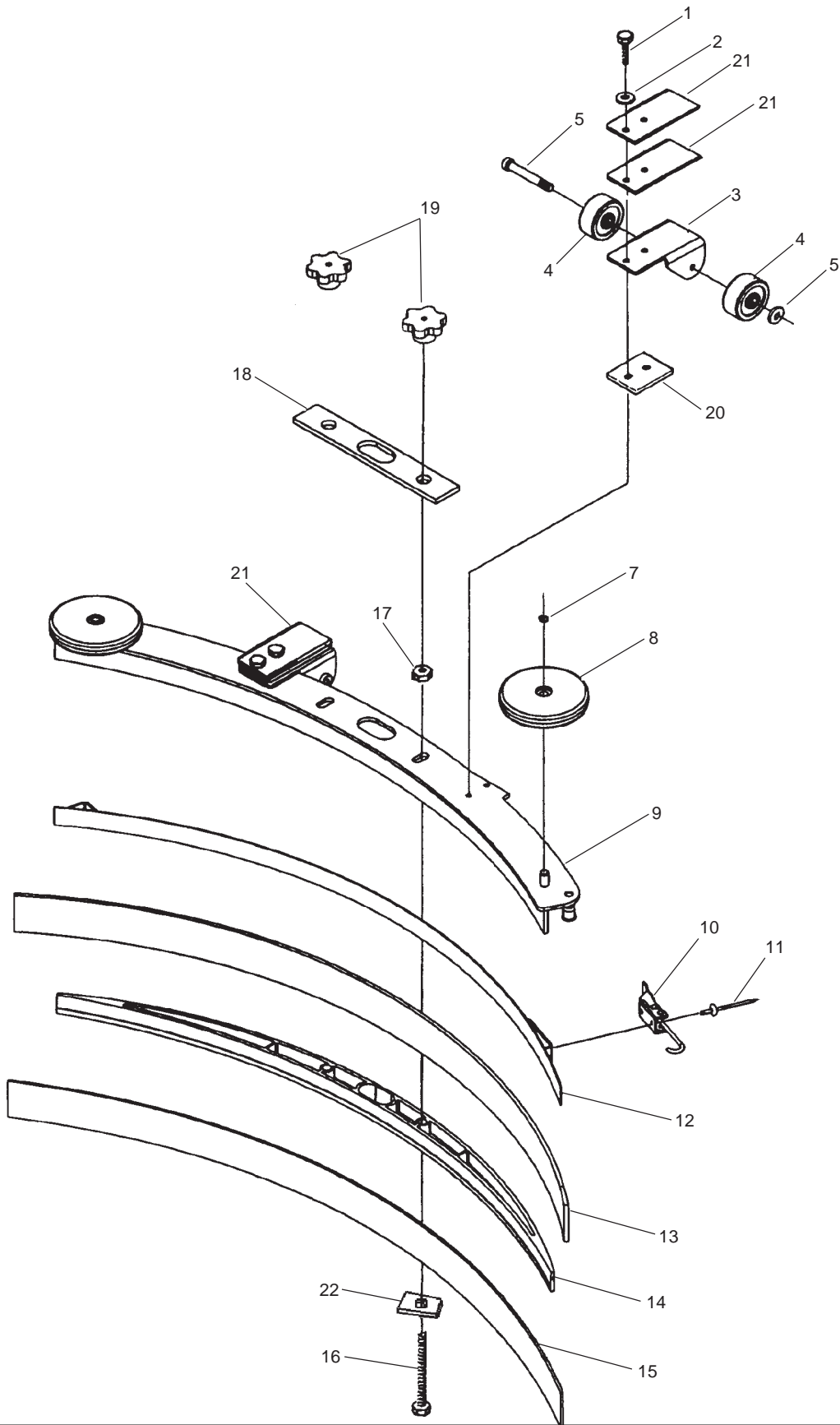

Clarke®
BOOST™ 28

Squeegee Assembly Parts List 9/05

Ref. #	Part No.	Description	Qty
1	80252A	Screw, ¼-20 x 1 Hex SS	4
	80253A	Screw, ¼-20 x 1½ Hex SS	4
2	980657	Washer, ¼ Lock	4
3	60243A	Bracket, Squeegee Wheel	2
4	30049B	Wheel, Squeegee	4
5	81104A	Nut, ¼-20	2
6	60254A	Bolt, Shoulder 5/16x 2¼	2
7	50958A	Ring, 3/8 ID Snap	2
8	30048A	Wheel, Guide, 4 Inch Diameter	2
9	60272A	Channel, Squeegee Weldment 39"	1
10	50835A	Latch, Squeegee Clamp	1
11	930086	Rivet, 3/16 x .450 Aluminum	2
12	60252A	Strap, Clamp, Squeegee Retainer 39"	1
13	30069A	Blade, Rear, Gum Rubber, 39"	1
14	30058A	Spacer, Squeegee 39"	1
15	30091A	Blade, Front Ribbed 39"	1
16	80011A	Screw, 3/8-16 x 3	2
17	81301A	Nut, 3/8-16 Jam SS	2
18	34260B	Gasket	1
19	25201A	Knob	2
20	60358A	Shim, Squeegee Wheel	2
21	61370A	Weight	8
22	80280A	Nut, Squeegee Backup	2

Clarke®
BOOST™ 28
Frame Axle Assembly Drawing 9/05

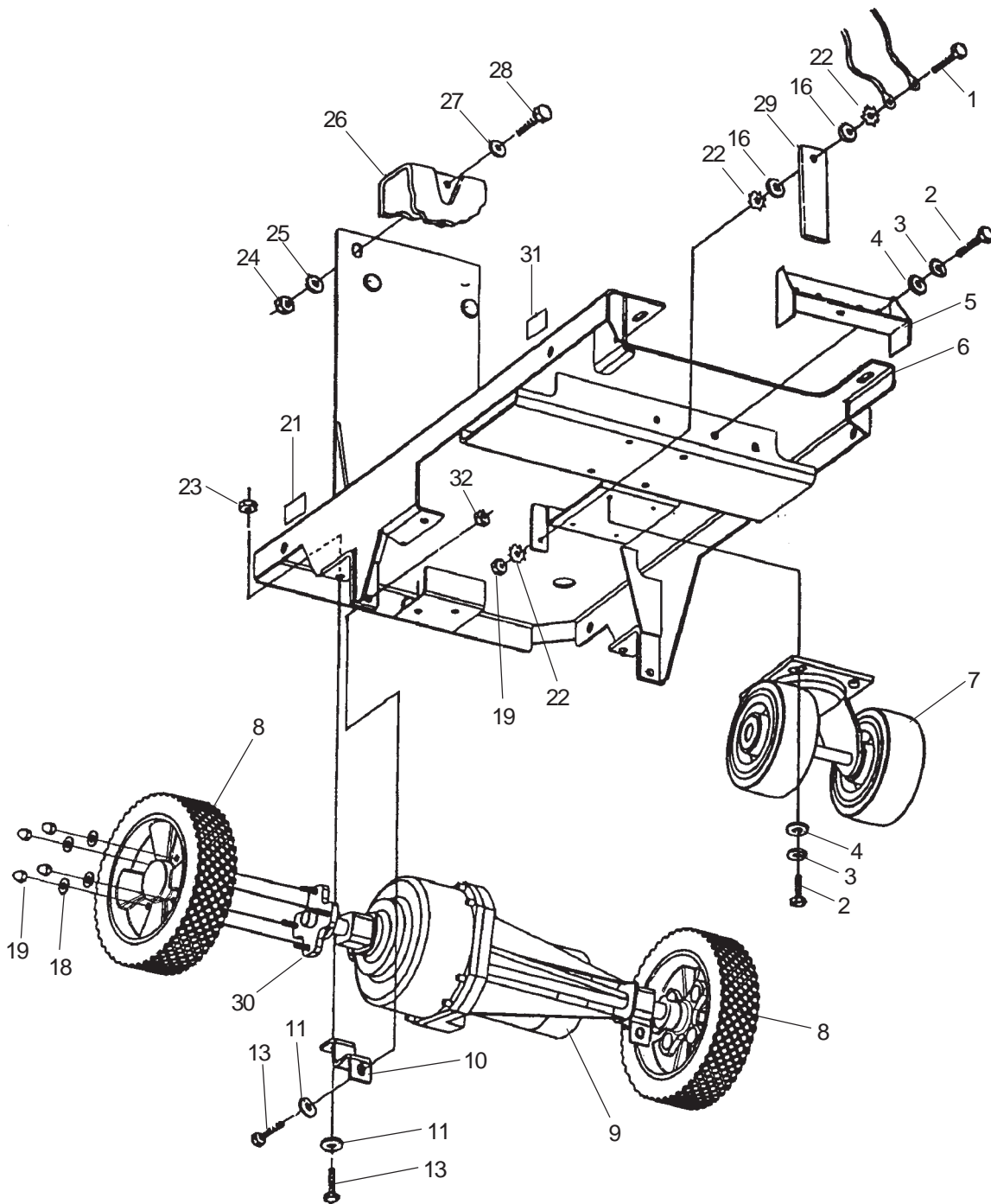

Frame Axle Assembly Parts List 9/05

Ref. #	Part No.	Description	Qty
1	85700A	Screw, ¼-20 x 1	1
2	85811A	Screw, 5/16-18 x ¾	6
3	980652	Washer, 5/16 Lock	6
4	980651	Washer, flat 5/16	6
5	60328A	Squeegee Mount	Ref
6	60260B	Frame Assembly	1
7	50968A	Caster, Assembly	1
8	61437A	Wheel Assembly	2
9	50967A	Transaxle w/mounting hubs	1
10	60289A	Mount, Transaxle	2
11	87031A	Washer, flat 3/8 SS	4
12	170883	Washer, 3/8 Lock	4
13	80103A	Screw, 3/8-24 x 1 Hex SS	4
14	57423A	Ring, Snap Retainer	2
15	87616A	Washer, Nylon	2
16	980205	Washer, 5/16 Fender	2
17	962620	Screw, 5/16-24 x ¾	2
18	87026A	Washer, Flat, ¼ SS	8
19	81104A	Nut, ¼-20 ESNA SS	9
21	77267A	Label, Tie Down	4
22	980614	Washer, ¼ Starlock	5
23	81108A	Nut, 3/8-24 ESNA	4
24	81105A	Nut, 3/8-16 ESNA	Ref
25	87031A	Washer, Flat 3/8 SS	Ref
26	Ref	Solution Tank	Ref
27	980205	Washer, 5/16	Ref
28	85734A	Screw, 3/8-16 x 2	Ref
29	69639A	Strap, Static	1
30	10135A	Flange, Hub Kit	1

**NOTE: 10135A (Flange, Hub Kit) contains 1 flange (hub), 2 snap rings, and 2 retaining keys.*

Clarke®
BOOST™ 28
Brush Head Assembly Parts List 9/05

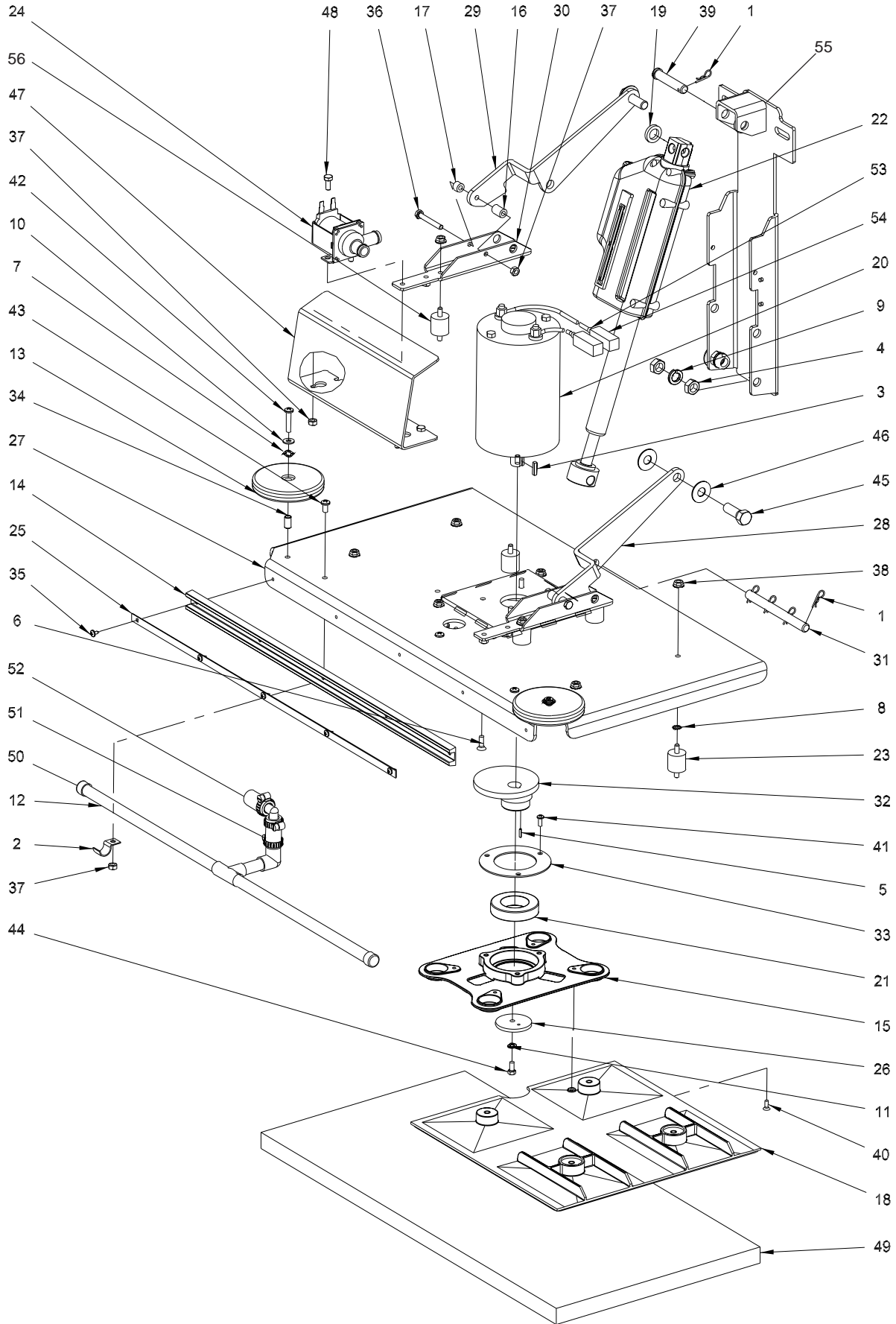

Brush Head Assembly Parts List 9/05

Ref. #	Part No.	Description	Qty
1	766780	Pin, Hair	5
2	782002	Clamp, Manifold	3
3	915082	Key, 3/16 SQ. x 3/4"	1
4	920278	Nut, Jam ½-20	4
5	925589	Pin, Roll	1
6	962098	Screw, ¼-20 x 3/4"	1
7	980022	Washer, Wave	2
8	980614	Washer, ¼" Starlock, External	8
9	980626	Washer, ½ Lock	2
10	980646	Washer, ¼" flat	2
11	980657	Washer, Lock ¼	1
12	11003A	Tube Assembly, Drip 28"	1
13	30048A	Wheel, Guide	2
14	30206A	Bumper	1
15	30663A	Plate, Driver	1
16	30670A	Spacer, Nylon	2
17	30671A	Spacer, Nylon	2
18	30674A	Plate, Flex, Asm. 32"	2
19	38723A	Spacer, 1.00 x .632 x .185	2
20	40790A	Motor, 24V	1
NI	11055A	Kit, Motor Brush Replacement	1
21	50736A	Bearing	1
22	53847A	Actuator	1
23	11063A	Rubber Isolator Kit	1
24	59789A	Valve, Solution	1
25	61425A	Retainer, Bumper	1
26	61724A	Retainer, Eccentric	1
27	61729A	Plate, Upper 28	1
28	61731A	Arm, Lift, Left	1
29	61732A	Arm, Lift, Right	1
30	61733A	Bracker, Lift	2
31	61750A	Rod Lift	1
32	61753A	Eccentric	1
33	61775A	Retainer, Bearing	1
34	61782A	Sleeve, Guide Wheel	2
35	80296A	Screw #10-24 x 7/16 Type 23	5
36	80298A	Screw, ¼-20 x 2.00 Hex Cap	2
37	81217A	Nut, ¼" x .218 ESNA	9
38	81220A	Nut, Serrated Flange	12
39	82501A	Pin, Clevis	1
40	84236A	Screw, 10-32 x .50 FH	4
41	84237A	Screw, 10-32 x .50 P.H.	3
42	85301A	Screw, ¼-20 x 1-¼ C.R.P.H.	2
43	85395A	Screw, ¼-20 x ½" P.H.	5
44	85737A	Screw, ¼-20 x ½ H.H.C.S.	1
45	85838A	Screw, ½-20 Hex	2
46	87607A	Washer, Flat	4
47	61813A	Guard, Front	1
48	962139	Screw, 1/4-20 x .625 Hex Cap	4
49	997004	Pad, Red, 32"	1
50	30708A	Endcap	2
51	722030	Clamp, Hose	4
52	30707A	Hose	1
53	40645A	Housing	2
54	41601A	Connectors	2
55	60236B	Bracket, Brush Head	1
56	11062A	Rubber Mounting Kit	1

Clarke®
BOOST™ 28
 Optional Brake Drawing and Parts List 9/05
 Drawing # 10072A

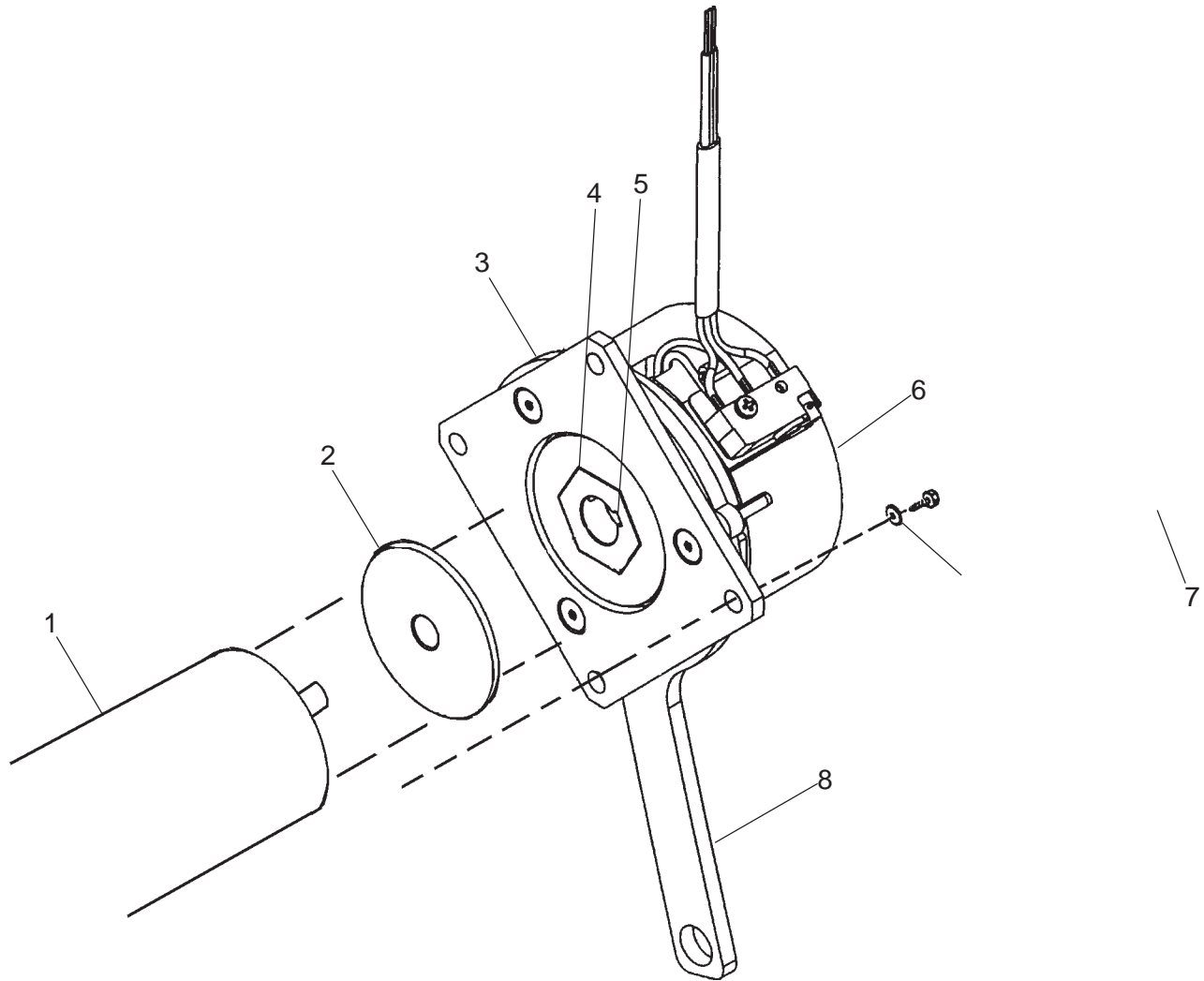

Ref #	Part No.	Description	Qty
1	50981A		
2	60388A	Spacer	1
3	30095A	Tie, Cover Retainer	1
4	80123A	Nut, Brake Drive	1
5	80125A	Key, 3/32 Sq. x 1/4 Lg.	1
6	30094A	Cover, Vinyl	1
7	80124A	Screw Set (Brake Nut to Motor Shaft)	2
8	10160A	Brake, Asm. 24V	1

NOTE: Only use spacer (ref. #2) on transaxles that have a circular step and mounting nuts protruding from end of motor. The motor that uses the spacer can be identified by the motor brush caps protruding past the outside diameter of the motor.

Clarke®
BOOST™ 28

Vacuum Motor Drawing and Parts List 9/05

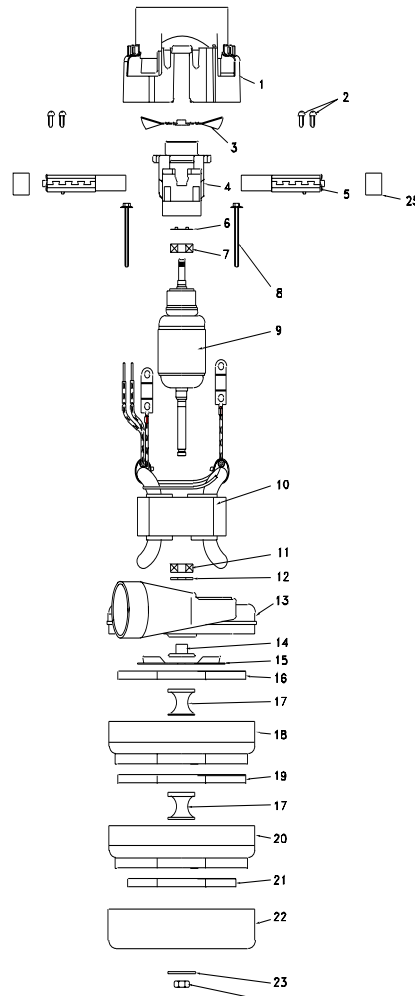

PARTS LIST

DESCRIPTION	REQUIRED	CLARKE 51049A	CLARKE 51050A
1. HOUSING	1	50994A	50994A
2. SCREW	4	*	*
3. FAN	1	50995A	50995A
4. COMM END BRACKET	1	*	*
5. BRUSH MECHANISM	2	50996A	50996A
6. LOAD SPRING	1	*	*
7. BALL BEARING	1	*	*
8. SCREW	2	*	*
9. ARMATURE	1	*	*
10. FIELD	1	*	*
11. BALL BEARING	1	*	*
12. NEOPRENE WASHER	1	59803A	59803A
13. FAN END BRACKET	1	*	*
14. SPACER	1	*	*
15. FAN	1	50997A	50997A
16. ROTATING FAN	1	53914A	
17. SPACER	2	50999A	
	1		50999A
18. STATIONARY FAN	1	51043A	51043A
19. ROTATING FAN	1	51044A	51044A
20. STATIONARY FAN	1	51045A	NA
21. ROTATING FAN	1	50998A	NA
22. FAN SHELL	1	51046A	51047A
23. WASHER	1	*	*
24. NUT	1	*	*
25. INSULATOR BRUSH CAP	2	51048A	51048A

1. THIS INFORMATION IS FOR PART IDENTITY ONLY, IT IS NOT TO BE USED AS DISASSEMBLY OR ASSEMBLY INSTRUCTIONS.
2. REPLACEMENT OF ARMATURE OR FIELD REQUIRES THE REPLACEMENT OF BRUSH MECHANISMS.

Clarke®
BOOST™ 28
Transaxle Drawing 9/05

REF. NO.	PART NO.	DESCRIPTION	QTY.
1	10135A	FLANGE, WHEEL KIT	2
2	51056A	SLEEVE, ELASTOMERIC	2
3	50983A	COUPLING, MOTOR DRIVE	1
4	50982A	TRANSAXLE, W/O MOTOR	1
5	50981A	MOTOR	1
PARTS LIST			

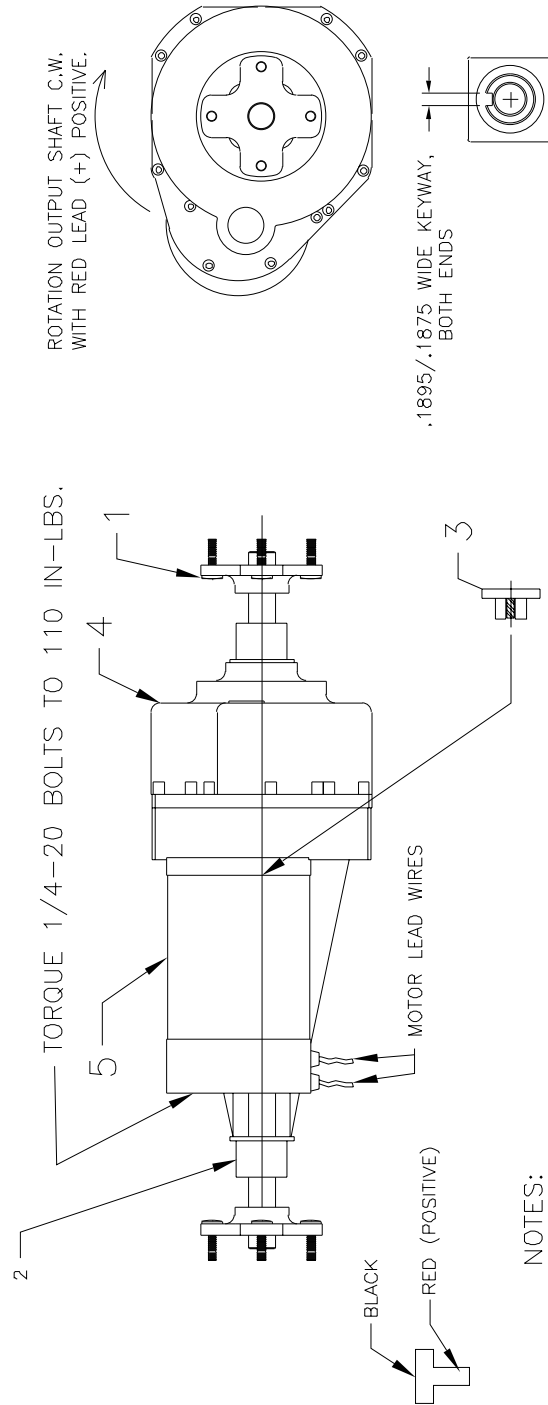

- NOTES:**
1. BALL AND NEEDLE BEARING CONSTRUCTION.
 2. GEARBOX GREASE LUBRICATED AND LEAKPROOF.
 3. AXLES TO BE RUST PROTECTED WITH PLATING
 4. GEAR RATIO: 18:1
 5. TRANSAXLE ASSEMBLY SUPPLIED WITH RUBBER MOUNT BUSHINGS INSTALLED.
 6. MOTOR ASSEMBLY IS FIELD REPLACEABLE.
 7. MOTOR FRAME ZINC PLATED.
 8. WHEEL FLANGES & STUDS TO BE ZINC PLATED.
 9. ELECTRICAL CONNECTORS - USE PACKARD HOUSING # 2984883 AND PACKARD TERMINAL # 2971859

Clarke®
BOOST™ 28

Battery Charger Drawing and Parts List 9/05

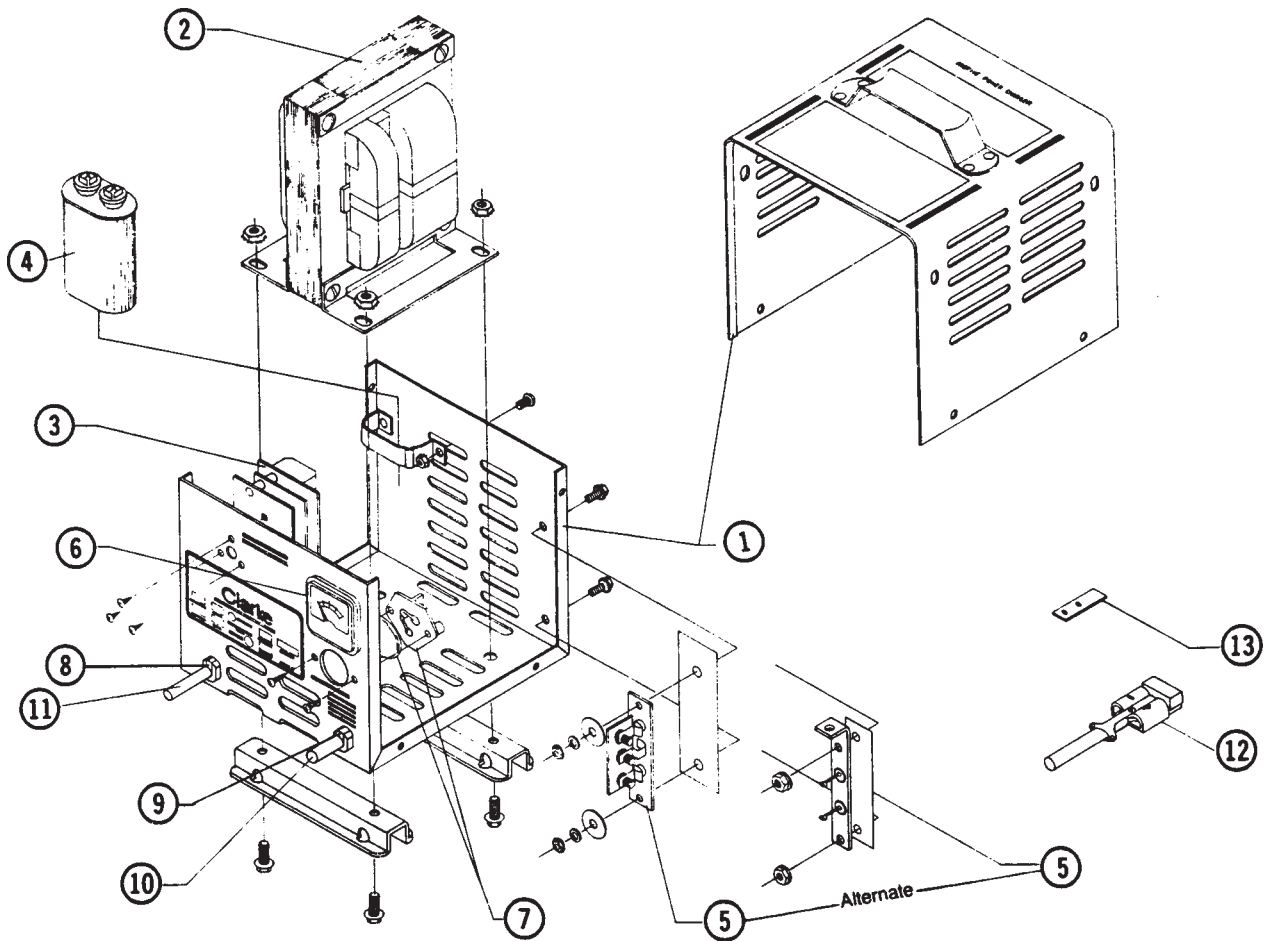

WARNING: All electrical repairs must be performed by qualified personnel only.

Charger #40512A: 24 volt, 25 amp D.C., 115 volt, A.C., 60 Hz.

Charger #40513A: 24 volt, 25 amp D.C., 230 volt, A.C., 50 Hz

Ref. No.	Description	Charger 40512A	Charger 40513A
1	Charger Case	41129A	41128A
2	Transformer	48413A	48409A
3	Electronic Controller Kit	47500A	48200A
4	Capacitor, 660 V.A.C.	912132	912132
5	Heat Sink Assembly	912212	912212
6	Ammeter	40200A	40200A
7	Fuse Holder	912382	912382
8	Strain Relief, A.C. Cord	837525	837525
9	Strain Relief, D.C. Cord	747553	747553
10	D.C. Cord Assembly	51986A	51986A
11	A.C. Cord Assembly	51974A	908947
12	Housing, Red	911470	911470
13	D.C. Plug Lock Key	795020	795020

* NOTE: Parts not available at this time.

Clarke® BOOST™ 28 Connection Diagram 9/05

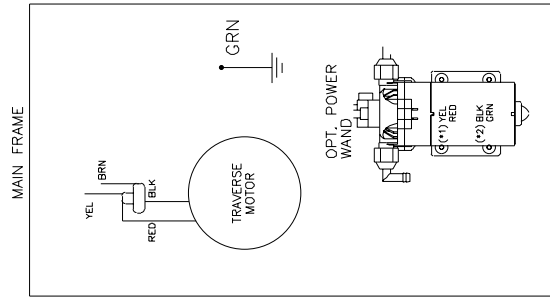

* = NOT CONNECTED
OPT.#1= POWERWAND OPTION

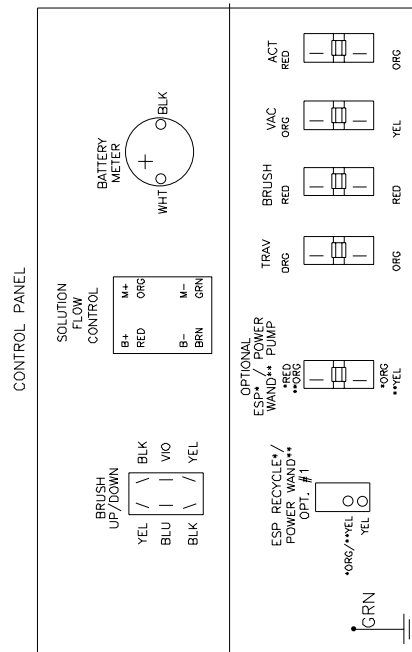
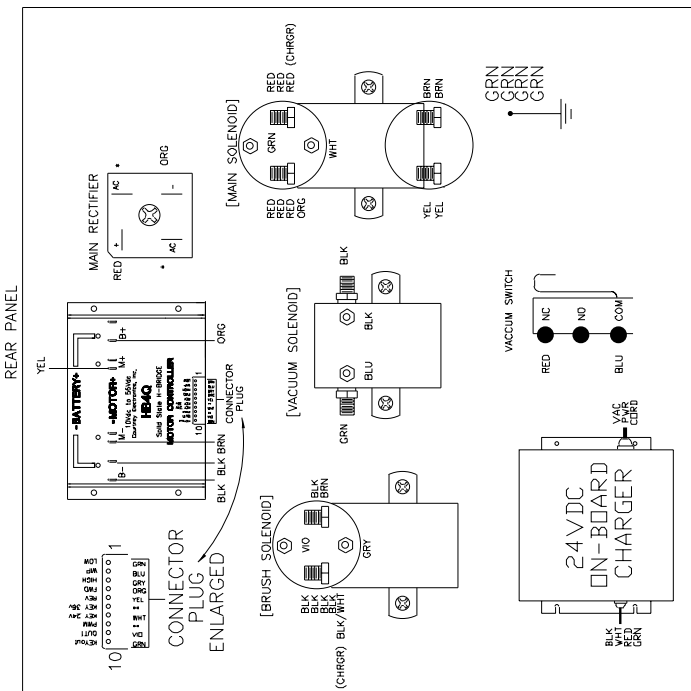
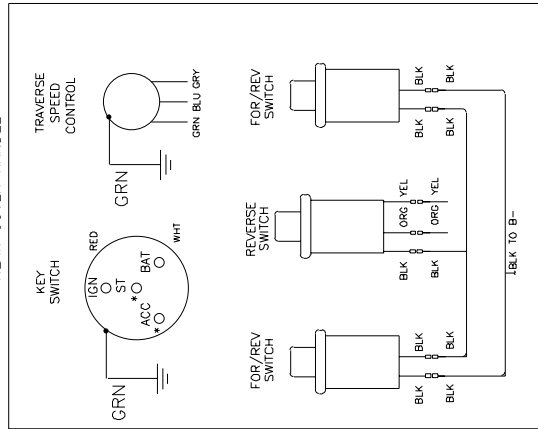
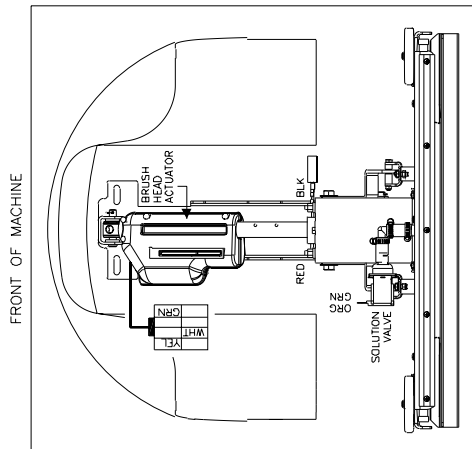
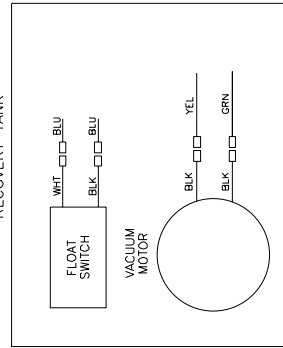

Clarke® BOOST™ 28 Electrical Schematic 9/05

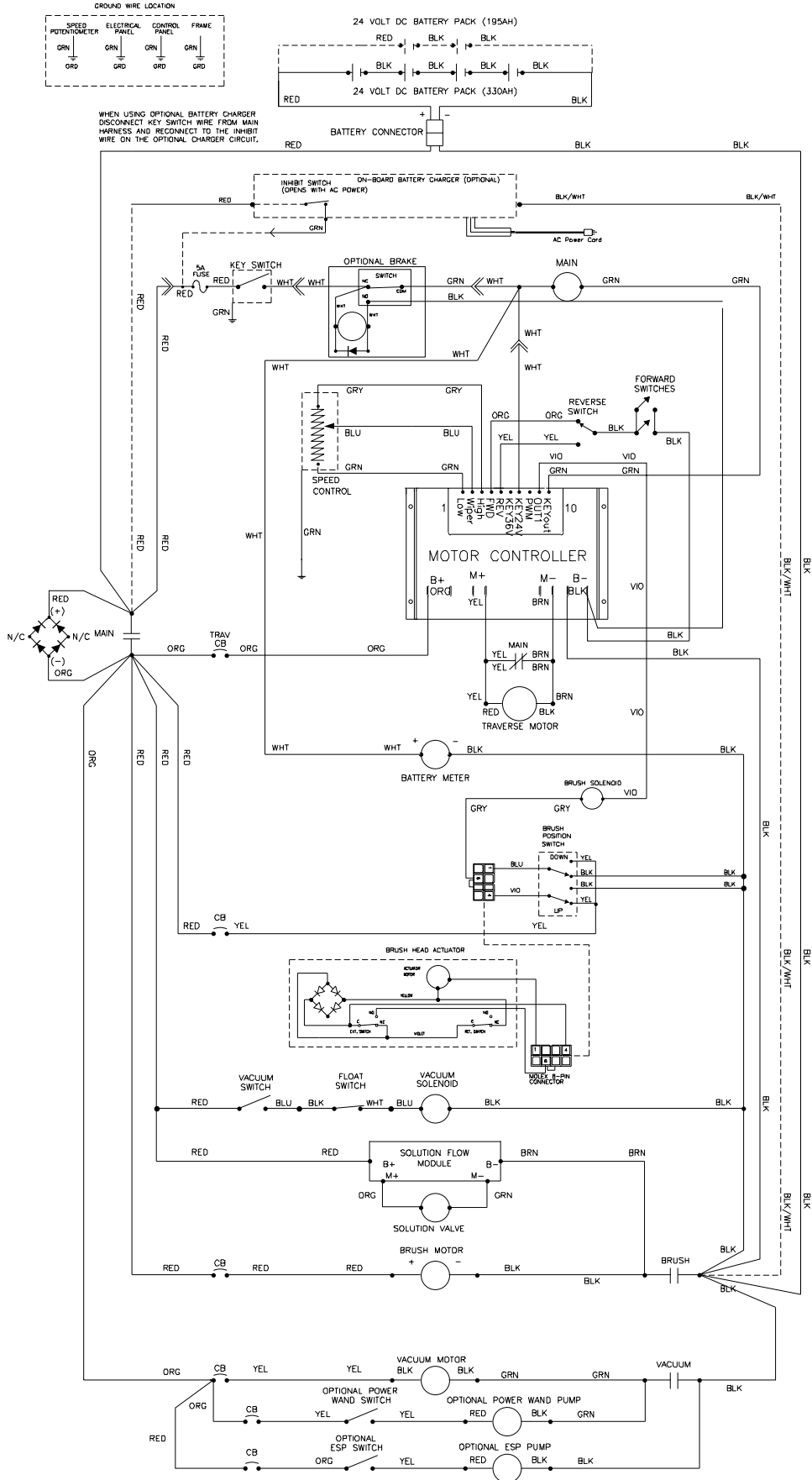

CLARKE PRODUCT SUPPORT BRANCHES

U. S. A. Locations

PRODUCTION FACILITIES

Clarke®, Springdale, Arkansas
2100 Highway 265
Springdale, Arkansas 72764
(479) 750-1000

Customer Service - 1-800-253-0367

Technical Service - 1-800-356-7274

American Lincoln®, Bowling Green, Ohio 43402
1100 Haskins Road

SERVICE FACILITIES

Clarke®, Elk Grove, Illinois 60007
2280 Elmhurst Road
(847) 956-7900

Clarke®, Denver, Colorado 80204
1955 West 13th Ave.
(303) 623-4367

Clarke®, Houston, Texas 77040
7215 North Gessner Road
713-937-7717

SERVICE AND SALES FACILITY

American Lincoln® / Clarke, Madison Heights,
Michigan 48071-0158
29815 John R.
(810) 544-6300

American Lincoln® / Clarke, Marietta, Georgia 30066
1455 Canton Road
(770) 973-5225

SALES AND DISTRIBUTION CENTER

Clarke®, Secaucus, NJ 07094
74 Henry Street
(201) 864-5503

Clarke®
Clarke American Sanders
A.L. Cook
Customer Service Headquarters and Factory
2100 Highway 265
Springdale, Arkansas 72764
(479) 750-1000

Technical Service
1-800-356-7274

European Locations

PRODUCTION FACILITIES

ALTO Danmark A/S, Aalborg
Blytaekervej 2
DK-9000 Aalborg
+45 72 18 21 00

ALTO Danmark A/S, Hadsund
Industrikvarteret
DK-9560 Hadsund
+45 72 18 21 00

SALES SUBSIDIARIES

Clarke® Canada Ltd., Rexdale Ontario
24 Constellation Ct.
(416) 675-5830

ALTO Overseas Inc., Sydney (Australia)
1B/8 Resolution Drive
Caringbah NSW 2229
+61 2 9524 6122

ALTO Cleaning Systems Asia Pte Ltd., Singapore
No. 17 Link Road
Singapore 619034
+65 268 1006

ALTO Deutschland GmbH, Bellenberg (Germany)
Guido-Oberdorfer-Straße 2-8
89287 Bellenberg
+49 0180 5 37 37 37

ALTO Cleaning Systems (UK) Ltd., Penrith
Gilwilly Industrial Estate
Penrith
Cumbria CA11 9BN
+44 1768 868 995

ALTO France S.A. Strasbourg
B.P. 44, 4 Place d'Ostwald
F-67036 Strasbourg
Cedex 2
+33 3 8828 8400

ALTO Nederland B.V.
Postbus 65
3370 AB Hardinxveld-Giessendam
The Netherlands
+31 184 677 200

ALTO Sverige AB, Molndal (Sweden)
Aminogatan 18
Box 4029
S-431 04 Molndal
+46 31 706 73 00

ALTO Norge A/S, Oslo (Norway)
Bjornerudveien 24
N-1266
+47 2275 1770

Clarke® LIMITED U.S. WARRANTY

This Clarke Industrial/Commercial Product is warranted to be free from defects in materials and workmanship under normal use and service, when operated and maintained in accordance with Clarke's Maintenance and Operations instructions. The warranty period is subject to the conditions stated below.

3 YEARS FOR PARTS AND 1 YEAR FOR SERVICE LABOR (See exceptions below)

Motors must be inspected for carbon motor brush wear at six-month intervals by an authorized Clarke repair station. Failure to comply with the six-month inspection requirement or failure to replace worn motor brushes identified during the inspection will void the warranty on the motors. Cost of the six-month inspection and replacement of carbon motor brushes is the responsibility of the purchaser. In the event of a warranty claim on the motors, proof of inspection and any required motor brush replacement must be provided. This warranty is extended only to the original purchaser for use of the product. It does not cover normal wear parts such as electrical cable, rubber parts, hoses and motor brushes.

BATTERY WARRANTY

In addition to the items above, any original equipment Clarke Battery which becomes unserviceable under normal use within a period of ninety (90) days from date of sale to the original user will be repaired or replaced with one of equal specification at our option, F.O.B. any authorized Clarke Sales or Service Branch, with no charge to the user, except transportation costs. After expiration of the above ninety (90) day period, any battery which fails under normal use will be adjusted to the original user with a new battery of equal specification on an eighteen (18) months pro rate basis from the date of purchase. Adjustment will be determined using the then current list price, plus transportation costs.

Warranty is rendered null and void if battery is not kept filled to the proper level with DISTILLED WATER.

CLARKE: POLYDUR® AUTOMATIC SCRUBBER SOLUTION AND RECOVERY TANK EIGHT-YEAR U.S. GUARANTEE

Your new Clarke machine has polydur Solution and Recovery Tanks. Polydur is a rotationally molded, low-density linear polyethylene that won't crack or dent, and withstands most corrosives and temperature extremes. Clarke backs up your Polydur tanks with an eight-year guarantee. If a tank breaks or leaks under normal use within eight years of the date of purchase, it will be replaced free.

CLARKE UNIBODY FRAME EIGHT-YEAR U.S. WARRANTY

Clarke warrants the frame of this machine for a period of eight years against defects in materials and workmanship under normal use and service.

STATED WARRANTIES ARE IN LIEU OF ALL OTHER WARRANTIES, EXPRESSED OR IMPLIED

Clarke's liability under this warranty is limited to repair of the product and/or replacement of parts and is given to purchaser in lieu of all other remedies, including INCIDENTAL AND CONSEQUENTIAL DAMAGES.

THERE ARE NO EXPRESS WARRANTIES OTHER THAN THOSE SPECIFIED HEREIN. THERE ARE NO WARRANTIES WHICH EXTEND BEYOND THE DESCRIPTION OF THE FACE HEREOF. NO WARRANTIES, INCLUDING BUT NOT LIMITED TO WARRANTY OF MERCHANTABILITY, SHALL BE IMPLIED. A warranty registration card is provided with your Clarke product. Return the card to assist Clarke in providing the performance you expect from your new floor machine.

If a difficulty develops with the product, you should: a) Contact the nearest authorized Clarke repair location or contact the Clarke Service Operations Department, 2100 Highway 265, Springdale, Arkansas 72764, for the nearest authorized Clarke repair location. Only these locations are authorized to make repairs to the product under this warranty. (b) Return the product to the nearest Clarke repair location. Transportation charges to and from the repair location must be prepaid by the purchaser. Clarke will repair the product and/or replace any defective parts with out charge within a reasonable time after receipt of the product. Clarke, 2100 Highway 265, Springdale, Arkansas 72764.

Clarke reserves the right to make changes or improvements to its machine without notice.

Always use genuine Clarke Parts for repair.

Clarke®

**2100 Highway 265
Springdale, Arkansas, 72764**