



SSS SWEEPERS

MODELS MS-31 & MS-39

INTRODUCTION

OPERATING & MAINTENANCE INSTRUCTIONS

READ THIS BOOK

This operator's book has important information for the use and safe operation of this machine. Read this book carefully before starting the machine. Keep this book and tell all operators to read the book. If you do not follow the instructions, you can cause an injury or damage equipment, furniture or buildings.

For new books write to:

Triple S
2 Executive Park Drive
Billerica, MA 01862

Carefully inspect all components to ensure that there is no concealed freight damage. If such damage is discovered, file a "CONCEALED DAMAGE REPORT" immediately with the delivering carrier.

The contents of this manual are based on the latest product information available at the time of publication. Triple S reserves the right to make changes or improvements to its machines without notice.

**FOR YOUR CONVENIENCE, RECORD THE
MACHINE MODEL AND SERIAL NUMBER:**

MODEL _____

SERIAL NUMBER _____

PURCHASED FROM _____

DATE PURCHASED _____

NOTES

OPERATION AND MAINTENANCE

Introduction

The SSS Sweepers, Models MS-31 and MS-39 are designed with three brushes: two counter rotating circular brushes and one centrally located cylindrical brush. The two circular brushes pick up small and large debris and the cylindrical brush removes the remaining fine debris. The sweepers are for use on hard, flat surfaces. The sweepers will pick up paper, leaves and general litter – both inside and out. However they are not designed for dust. The debris is swept into the hopper and the hopper is easily removed by lifting the handle; then the hopper can be carried separately for disposal of the debris.

Assembly

Your sweeper requires little assembly before operation. Follow these simple steps:

Assemble the operator's handle. The machine handle is shipped in three parts: the "U" shaped tube and two black lower sections (or holders).

- 1. First connect each black holder to the U tube.** Depress the spring button on the U tube, then slide the black holder on until the spring button clicks into the hole.
- 2. Connect the handle assembly to the machine.** Simply slide the handle assembly over the recessed holes on each side of the front cover. Then snap into the holes to lock in place.

Operation

This sweeper can be used for both indoor and outdoor sweeping.

DO NOT PICK UP ANYTHING THAT IS BURNING OR SMOKING, SUCH AS CIGARETTES, MATCHES OR HOT ASHES.

- 1. Make sure the hopper and front cover are securely fastened.** Slots in the hopper slide over locators on the front cover. After the hopper and front cover are fitted together, push the hopper's handle down. This will latch the hopper to the front cover.
- 2. Adjust the brush pressure to accommodate your pick up needs.** The height adjustment dial is located on the front of the sweeper. For larger debris use a high setting, number 1 is the highest position. Move to a higher number (lower position) for picking up finer debris. Do not press the brushes too firmly to the ground because this will eventually wear out the drive mechanism.

3. Start sweeping. The overlapping brushes ensure good coverage. Dirt and debris will be pushed into the hopper as soon as you begin pushing the sweeper. The carrying capacity of the hopper can be increased by raising the front of the sweeper, this will move debris to the back of the hopper.

4. Empty the hopper when you're done sweeping. Simply pull up on the hopper's handle and lift the hopper off the front cover. Dispose of the debris in an approved waste receptacle. **Clean** the hopper if necessary. **Reattach** the hopper to the front cover.

5. Store the sweeper indoors.

Maintenance

- 1. Clean the hopper and machine** by wiping with a dry cloth as needed.
- 2. Brushes:** After each use, remove any strings or debris.
- 3. Replacement or Cleaning of the Angled Wheels (24):** Set the height adjustment dial to position 8. Pull the angled wheel strongly, to remove it and its axle from the tooth sleeve. Clean or replace the wheel, then push it firmly back into the tooth sleeve. Make sure you place the wheels back in their correct positions, they are marked L and R for the left and right positions.
- 4. Cleaning or Replacement of the Circular Brushes (28) and Clutch Assembly (26 & 27):** Remove the angled wheel (24) as explained in Step 3. Pull the brush towards you - the brush and clutch assembly will come away from the pivot housing. The clutch assembly can now be pulled away from the brush. The brushes and clutch assembly may be cleaned with water. The gears should only be lubricated with silicone spray.

Ensure that the brushes and clutch assemblies are fitted on the correct side of the sweeper when reassembling. To guide you, the inside of the front cover is marked L and R, as are the wheels and each brush is marked L/// and R\\ which indicates the direction of the bristle point. To reassemble, place the brush over the pivot housing then push the clutch assembly over the pivot housing. Refit the angled wheel.

MS-31 & MS-39

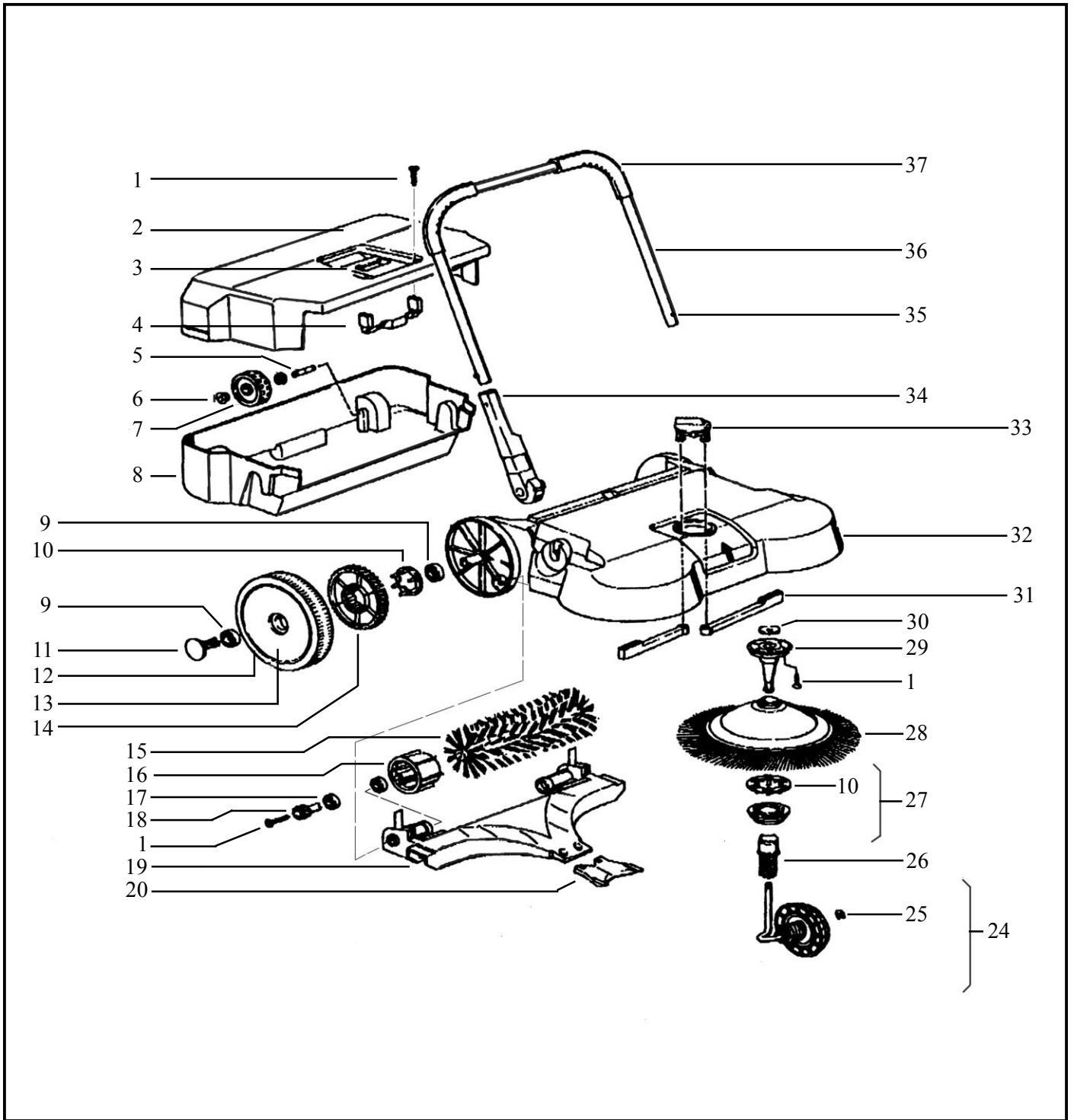

PARTS LIST

ITEM	PART NUMBER	DESCRIPTION	QTY
1	964151	Screw	
2	712315	Cover, Hopper	1
3	703901	Handle, Hopper	1
4	712015	Clamp	1
5	717701	Axle for Hopper	2
6	711115	Bushing	4
7	719704	Tread Wheel	2
8	712316	Bottom, Hopper	1
9	902037	Ball Bearing 6805zz	4
10	712415	Clutch Element Ring	2
11	712016	Wheel Clamp	2
12	719215	Tread Wheel	2
13	719716	Wheel	2
14	713516	Pinion (Gear)	2
15	710916	Cylindrical Brush	1
16	712716	Driver, Brush	2
17	902036	Ball Bearing 6903zz	4
18	713515	Pinion (Gear)	2
19	716615	Sweeping Plate	1
20	715101	Sweeping Lip	1
24	719715L	Wheel w/Axle Left - MS-31	1
	719715R	Wheel w/Axle Right - MS-31	1
	719720L	Wheel w/Axle Left - MS-39	1
	719720R	Wheel w/Axle Right - MS-39	1
25	980634	Washer, 6mm	2
26	713502	Tooth Sleeve	2
27	712410	Clutch Complete Left	1
	712411	Clutch Complete Right	1
28	710915L	Circular Brush Left - MS-31	1
	710915R	Circular Brush Right - MS-31	1
	710920L	Circular Brush Left - MS-39	1
	710920R	Circular Brush Right - MS-39	1
29	714215	Pivot Housing	2
30	980638	Washer Pivot Housing	2
31	718515	Adjustment Slide -MS-31	2
	718520	Adjustment Slide -MS-39	2
32	713215	Frame - MS-31	1
	713220	Frame - MS-39	1
33	712715	Dial: Height Adjustment	1
34	715117	Holder for Sliding Lever	2
35	712115	Spring Clip	2
36	715116	"U" Handle Tube (Sliding Lever)	1
37	713903	Grip, Handle	2

**SSS SWEEPER, MODELS MS-31 & MS-39
LIMITED WARRANTY**

The SSS Sweeper has been manufactured, tested and inspected in accordance with specific engineering requirements, and is WARRANTED by the manufacturer to be free from defects in workmanship and materials.

This warranty is, however, subject to the following qualifications, conditions and limitations which are set forth to provide you and all users of the SSS Sweeper with information concerning the duration, extent, availability and applicability of this Limited Warranty, the procedure to be taken to obtain its performance and other information concerning the manufacturer's warranty policy.

1. TO WHOM EXTENDED AND DURATION OF ITEMS COVERED

This warranty extends to the original consumer purchaser from the date it was purchased and for the items and period as follows:

One (1) year - All components unless excluded below.

2. PARTS NOT COVERED BY WARRANTY

Certain parts of the SSS Sweeper require replacement in the ordinary course of use due to normal wear by reason of their characteristics. This warranty does not cover the following normal wear items:

Part Number	Part Name
710915L	Circular Brush, Left (MS-31)
710915R	Circular Brush, Right (MS-31)
710920L	Circular Brush, Left (MS-39)
710920R	Circular Brush, Right (MS-39)
710916	Cylindrical Brush

3. EXCEPTIONS AND EXCLUSIONS FROM WARRANTY

Defects, malfunctions, failure or damage of the SSS Sweeper caused by improper, unreasonable or negligent use or abuse while in the possession of the consumer are likewise excluded from this warranty.

If repair is done on your SSS Sweeper by anyone other than those below designated as authorized to perform such work without first having obtained factory instructions, the manufacturer, at its sole option, may determine that this warranty will not apply and that reimbursement for such repair will not be made because of the failure to comply with such factory specified instructions.

4. PROCEDURE TO BE TAKEN TO OBTAIN PERFORMANCE OF WARRANTY

To secure repair of the SSS Sweeper or any warranted parts under this warranty, the following procedure should be taken: The inoperative SSS Sweeper or warranted parts, together with satisfactory evidence of the purchase date, must be delivered with shipping and delivery charges prepaid to the Dealer from whom purchased.

If you are unable to locate the Dealer, you may write or otherwise communicate with **Triple S, 2 Executive Park Drive, Billerica, MA 01862** for instructions before repair service is performed by anyone else. In such event Triple S will provide either the location of a closely available Triple S distributor Service Department or other factory instructions.

Upon compliance with the above procedure, all warranted defects will be repaired, at no additional charge or costs to the consumer, and the repaired product returned to the consumer, with all shipping and delivery charges prepaid.

In following the procedures above set forth PLEASE MAKE CERTAIN to state the Triple S model, type and serial number as shown on the name plate of the SSS Sweeper.

REPLACEMENT

In the event of the defect, malfunction or failure of your SSS Sweeper or any warranted part to conform with this warranty, the manufacturer may at its sole option and own expense, replace the SSS Sweeper or any warranted part with another new identical or reasonably equivalent model or part in lieu of repairing the defect.

5. NO REFUND OF PURCHASE PRICE

Triple S will not, as a matter of its warranty policy, refund the consumer's purchase price.

6. WARRANTY REGISTRATION CARD FOR YOUR SSS SWEEPER AND REQUESTS FOR INFORMATION

Please fill out the warranty registration card accompanying your SSS Sweeper, giving complete information as requested on the card, and return to Triple S.

This warranty is in lieu of all other expressed or implied warranties.

