

Operator's Manual

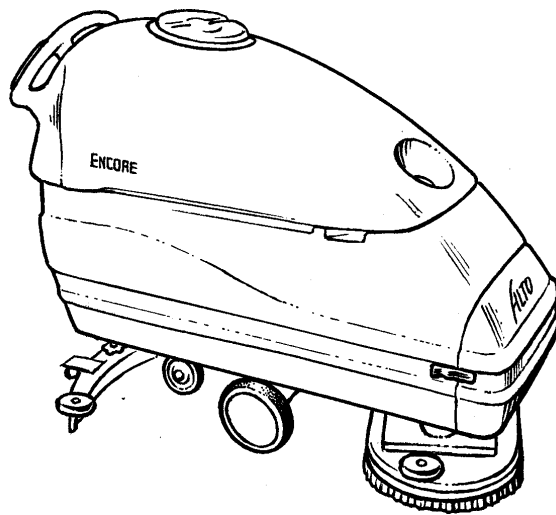

ENCORE
S2426/L2426

READ THIS BOOK

▲ CAUTION: Read the Operator's Manual before using the appliance.

This book has important information for the use and safe operation of this machine. Failure to read this book prior to operating or attempting any service or maintenance procedure to your ALTO machine could result in injury to you or to other personnel; damage to the machine or to other property could occur as well. You must have training in the operation of this machine before using it. If operator(s) cannot read this manual, have it explained fully before attempting to operate this machine.

Si Ud. o sus operadores no pueden leer el Inglés, se hagan explicar este manual completamente antes de tratar el manejo o servicio de esta máquina.

All directions given in this book are as seen from the operator's position at the rear of the machine.

For new books write to: ALTO U.S. Inc., 2100 Highway 265, Springdale, Arkansas 72764.

Table of Contents

Operator Safety Instructions	3
Introduction & Machine Specifications	5
Procedures for Transporting Machine	6
Symbols Used on Encore S2426 and L2426	8
Machine Control Panel	10
Machine Controls and Features	11
How to Prepare the Machine for Operation	12
How to Install the Batteries	12
Battery Maintenance	13
How to Charge the Batteries	14
How to Adjust Brush Cleaning Path	15
How to Install a Brush or Pad Driver	15
How to Remove a Brush or Pad Driver	16
How to Operate the Machine	16
How to Operate the Squeegee	16
Filling the Solution Tank	16
Operating the Machine	17
How to Clean a Dirty Floor	18
Maintenance	19
Procedures Before Work is Began	19
Procedures to Perform at the End of Work	20
Procedures to Perform Every Week	21
Maintenance for the Squeegee	22
How to Adjust the Squeegee	22
How to Clean the Solution Line	23
How to Center or Off set Brushhead	23
Accessories	25

SECTION II - Parts and Service Manual

How to Correct Problems in the Machine	28
Encore S2426/L2426 Final Assembly Drawing	30
Parts List	31
Recovery Tank Drawing	32
Parts List	33
Solution Tank Assembly Drawing	34
Parts List	35
Rear Panel Assembly Drawing	36
Parts List	37
Control Panel Assembly Drawing	38
Parts List	39
Squeegee Lift Assembly Drawing	40
Parts List	41
Squeegee Assembly Drawing	42
Parts List	43
Frame Axle Assembly Drawing	44
Parts List	45
Brush Head Assembly Drawing	46
Parts List	47
Optional Brake Assembly Drawing and Parts List "S" Model	48
Optional Brake Assembly Drawing and Parts List "L" Model	49
Vacuum Motor Drawing and Parts List	50
Gearbox Assembly Drawing and Parts List	51
Brush Motor Assembly Drawing and Parts List	52
Transaxle Repair Parts	53
Battery Charger Drawing and Parts List	54
Encore S2426 Connection Diagram	55
Encore S2426 Electrical Schematic	56
Encore L2426 Connection Diagram	57
Encore L2426 Electrical Schematic	58

OPERATOR SAFETY INSTRUCTIONS

 **WARNING**

 **AVERTISSEMENT**

 **ADVERTENCIA**

 **DANGER:** Failure to read and observe all **DANGER** statements could result in severe bodily injury or death. Read and observe all **DANGER** statements found in your Owner's Manual and on your machine.

 **WARNING:** Failure to read and observe all **WARNING** statements could result in injury to you or to other personnel; property damage could occur as well. Read and observe all **WARNING** statements found in your Owner's Manual and on your machine.

 **CAUTION:** Failure to read and observe all **CAUTION** statements could result in damage to the machine or to other property. Read and observe all **CAUTION** statements found in our Owner's Manual and on your machine.

 **DANGER:** Failure to read the Owner's Manual prior to operating or attempting any service or maintenance procedure to your Clarke Technology machine could result in injury to you or to other personnel; damage to the machine or to other property could occur as well. You must have training in the operation of this machine before using it. If you or your operator(s) cannot read English, have this manual explained fully before attempting to operate this machine.

 **DANGER:** Operating a machine that is not completely or fully assembled could result in injury or property damage. Do not operate this machine unless it is completely assembled. Inspect the machine carefully before operation.

 **DANGER:** Machines can cause an explosion when operated near flammable materials and vapors. Do not use this machine with or near fuels, grain dust, solvents, thinners, or other flammable materials. This machine is not suitable for picking up hazardous dust. Use only commercially available floor cleaning waxes intended for machine operation.

 **DANGER:** Lead acid batteries generate gases which can cause an explosion. Keep sparks and flames away from batteries. Do not smoke around the machine. Charge the batteries only in an area with good ventilation. Make sure that the AC charger plug is unplugged from the wall receptacle before connecting or disconnecting the DC plug to or from the battery pack.











 **DANGER:** Working with batteries can be dangerous! Always wear eye protection and protective clothing when working near batteries. Remove all jewelry. Do not put tools or other metal objects across the battery terminals, or the tops of the batteries.

 **DANGER:** Using a charger with a damaged power cord could result in an electrocution. Do not use the charger if the power cord is damaged.

 **WARNING:** Operating this machine from anywhere other than the back of the machine could result in injury or damage. Operate this machine only from the rear.

 **WARNING:** This machine is heavy. Get assistance before attempting to transport or move it. Use two able persons to move the machine on a ramp or incline. Always move slowly. Do not turn the machine on a ramp. Do not use on surfaces having a gradient exceeding that marked on the appliance. Read the "Procedures For Transporting" in this manual before transporting as machine might topple over if not secured.

 **WARNING:** Machines can topple over and cause injury or damage if guided over the edges of stairs or loading docks. Stop and leave this machine only on a level surface. When you stop the machine, put all switches into their "OFF" position. Turn the key switch "OFF" and remove the key.

-  **WARNING:** Maintenance and repairs performed by unauthorized personnel could result in damage or injury. Maintenance and repairs must be performed by authorized Clarke Technology personnel only.
-  **WARNING:** Any alterations or modifications of this machine could result in damage to the machine or injury to the operator or other bystanders. Alterations or modifications not authorized by the manufacturer voids any and all warranties and liabilities.
-  **WARNING:** Electrical components of this machine can "short-out" if exposed to water or moisture. Keep the electrical components of the machine dry. Wipe the machine down after each use. This appliance is for dry use only and is not to be used or stored outdoors in wet conditions.
-  **WARNING:** Operating a machine without observing all labels and instructional information could result in injury or damage. Read all machine labels before attempting to operate. Make sure all of the labels and instructional information are attached or fastened to the machine. Get replacement labels and decals from your Clarke Technology distributor.
-  **WARNING:** Wet floor surfaces can be slippery. Water solutions or cleaning materials used with this type of machine can leave wet areas on the floor surface. These areas can cause a dangerous condition for the operator or other persons. Always put "Caution" signs around/near the area you are cleaning.
-  **WARNING:** Improper discharge of waste water may damage the environment and be illegal. The United States Environmental Protection Agency has established certain regulations regarding discharge of waste water. City, state and national regulations regarding this discharge may also be in effect in your area. Understand and follow the regulations in your area. Be aware of the environment hazards of chemicals that you dispose.
-  **WARNING:** Only use the brushes provided with the appliance or those specified in the Operator's Manual. The use of other brushes may impair safety.
-  **CAUTION:** Use of this machine to move other objects or to climb on could result in injury or damage. Do not use this machine as a step or furniture. Do not ride on this machine.
-  **CAUTION:** Your machine warranty will be voided if anything other than genuine Clarke Technology parts are used on your machine. Always use Clarke Technology parts for replacement.
-  **CAUTION:** This machine contains lead acid batteries. The batteries must be disposed of in an environmentally acceptable manner.

Introduction & Machine Specifications

Introduction & Machine Specifications

Clarke Technology's newly designed Encore S2426 and L2426 automatic scrubbers are efficient and superior floor cleaning machines. The Encore uses two brushes to scrub a path 24 or 26 inches wide. A squeegee wipes the floor while the vacuum motor removes the dirty solution from the floor - all in one pass.

The Encore S2426 comes complete with either four - 6 volt batteries or two - 12 volt batteries, one battery charger, either two brushes or two pad drivers, and one operator's manual.

The Encore L2426 comes complete with four - 6 volt batteries, one battery charger, either two brushes or two pad drivers, and one operator's manual.

SPECIFICATIONS:

Model	Encore L2426	Encore S2426
Machine Power Supply	24 Volt D.C., (4) 6V 250 AH Deep Cycle Batteries or (4) 6V 330 AH Deep Cycle Batteries	24 Volt D.C., (2) 6V 195 AH Deep Cycle Batteries or (4) 6V 250 AH Deep Cycle Batteries or (4) 6V 330 AH Deep Cycle Batteries
Pad or Brush 2 per machine	Gimbal Style	3-Lug Driver Style
Traverse	0.5 hp (0.4 kW) Transaxle	Brush Assist
Traverse Forward Speed	Variable to 250 ft./min (76 m/min)	Not Applicable
Traverse Reverse Speed	Variable to 190 ft./min. (58 m/min)	Not Applicable
Battery Protection	Low Voltage	
Motor Vacuum	3/4 HP, 3 stage, Acoustical High Efficient Tangential	
Solution Tank	20 Gallons (76 liters)	
Solution Level	Calibrated level indicator on rear of machine	
Recovery Tank	20 Gallons (76 liters)	
Recovery Full Indicator	Electric Shut-Off	
Parabolic Squeegee	Swing type with breakaway feature, No tool operation feature 32 inches (81 cm) hard width with 34 inches (86 cm) flex blade width.	
Squeegee Operation	Reverse direction on floor and 3 - position manual lever style operation	
Cleaning Swath	24 or 26 inch (61 or 66 cm) adjustable head	
Motor, Brush	0.75 HP (0,56 kW) 5.2:1 High Torque Gear Box	
Brush / Pad Size	(2) 13 inch (33 cm)	
Brush Speed	200 RPM	
Brush Pressure	0-150 lbs. / 0-68 kg.	
Brush Solution Retention	Fiber Bristles	
Drive Wheels	(2) 8 in. x 2 in. (20 cm x 5 cm) Neoprene tread	
Caster	Dual 4 in. x 2 in. (10 cm x 5 cm)	
Charger	24 V D.C., 25 Amp, 115/60 or 24 V D.C., 25 Amp, 230/50	
Grade Cleaning	5 Degree (6%)	2%
Length	56 inches (142 cm)	
Width	28 inches (71 cm)	
Height	43 inches (109 cm)	
Weight	871 lb / 395 kg	
Line of Sight (from Operator Height): 68 inches (173 cm)	7.5 feet (2.3 m)	
Warranty	Machine 3 Years, Polydur tanks- 8 years	
	Batteries- 18 months, pro-rated	
Noise	71 dBA	71 dBA
Vibration	< 2.5 m/s ²	< 2.5 m/s ²

Procedures For Transporting

How to Put the Machine Into a Van or Truck

WARNING: This machine is heavy. Get assistance before attempting to transport or move it. Use two able persons to move the machine on a ramp or incline. Always move slowly. Do not turn the machine on a ramp. Do not stop and leave the machine on a ramp or incline. The loading ramp must be a minimum of 32" wide.

WARNING: Machines can topple over if guided over the edges of stairs or loading docks and cause injury or damage. Stop and leave this machine only on a level surface. When you stop the machine, put all switches into their "OFF" position.

1. Make sure the loading ramp is at least eight (8) feet (2.5m) long and a minimum of 32" (0.8m) wide, and strong enough to support the machine.
2. Make sure the ramp is clean and dry.
3. Put the ramp in position.
4. Remove squeegee assembly, brush housing and brush or pad driver before loading. ALTO recommends that both the solution tank and recovery tank are empty before loading.
5. Turn key switch "ON" (on L2426 model only).
6. Align the machine on a level surface five (5) feet (2 m) in front of the ramp.
7. Put the traverse knob at full speed (on L2426 model only).
8. For the L2426 machine, push in either one of the forward/reverse switches while pushing in the white reverse switch. Back the machine up the ramp. See figure 1.
9. For the S2426 machine, push the machine backwards to the top of the ramp.
10. Turn the key switch "OFF".

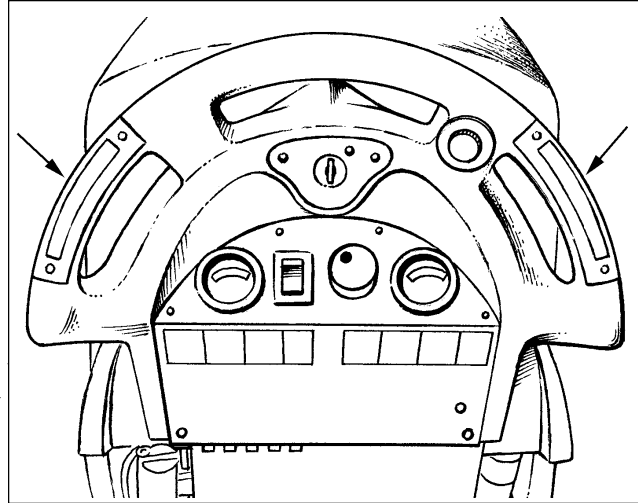

Figure #1

Procedures For Transpoting (cont.)

11. **Fasten the machine to the vehicle.** Clarke Technology recommends a strap over the top of the machine and a strap to keep the machine from rolling forward or backwards. If this is not done, there is a possibility of the machine toppling over. Four tie down points (2 along each side of frame) are provided on machine for securing machine.

How to Remove the Machine From a Van or Truck

1. Make sure there are no obstructions in the area.
2. Make sure the unloading ramp is at least eight (8) feet (2.5m) long and a minimum of 32" (0.8m) wide, and strong enough to support the machine.
3. Make sure the ramp is clean and dry.
4. Put the ramp in position.
5. Unfasten the machine.

▲ WARNING: The machine is heavy. Make sure you use two able persons to assist in moving the machine down the ramp.

6. On S2426 model, get two people to pull machine off ramp. It is recommended that the "S" model be unloaded in the forward position.
7. Turn the key switch "ON". (L2426 model only)
8. Set the traverse center knob to the slowest forward speed setting. Carefully and slowly, drive the machine to the top of the ramp and start down.
9. While pushing in the right or left forward/reverse switch the machine will go forward. See figure 2.
10. As the machine begins to travel down the ramp, push in the forward/reverse switch to maintain a slow downward speed.
11. Replace squeegee assembly, brush housing, and brush or pad driver after machine is unloaded and ready to use.

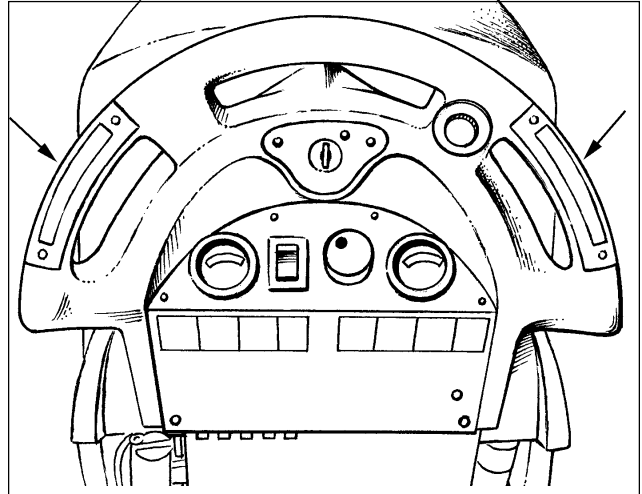
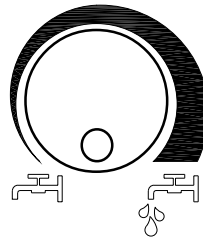

Figure #2

SYMBOLS USED ON ENCORE S2426 and L2426



Warning
("L Class" & "S Class")



Solution Control
("L Class" & "S Class")



Power
("L Class" & "S Class")

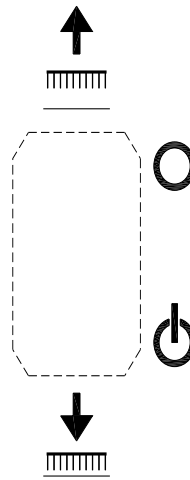

Brush Up/Down
("L Class" & "S Class")



Traverse Speed Control
("L Class")

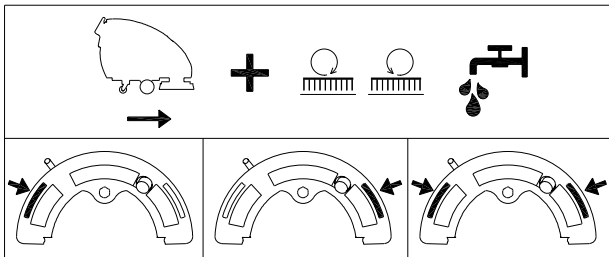

Traverse Directions Forward
(Traverse and Solution, and Brush Rotation)
("L Class")

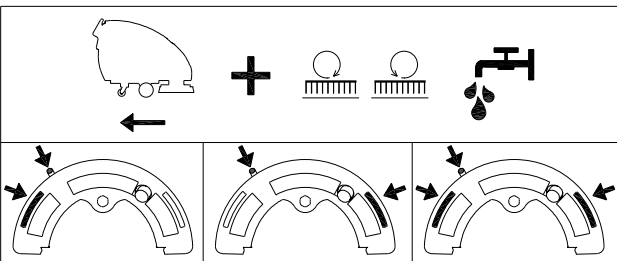

Traverse Directions Reverse
(Traverse and Solution, and Brush Rotation)
("L Class")

SYMBOLS USED ON ENCORE S2426 and L2426

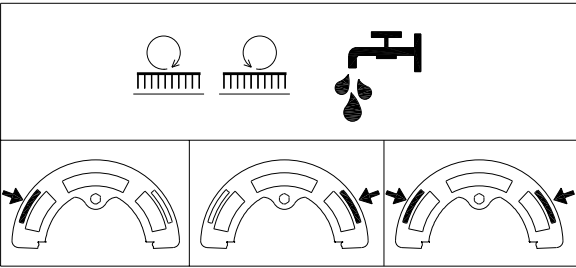

Solution/Brush Motors ("S Class")



Warning Label ("L Class" & "S Class") with parking brake



Warning Label ("L Class" & "S Class") without parking brake

Machine Control Panel

Key Switch (See Figure 3, Item "A")

The key switch turns "ON" the power to the control panel. "O" is "OFF" and "I" is "ON".

Forward Reverse Switch (See Figure 3, Item "B") On Traverse ("L") Model Only -

The forward/reverse switch turns the traverse motor "on" forward and if the brush motors are in the down position, activates the brush motors/solution control module. There is a two second delay for the pad motor to stop after releasing the switch. Either the right or the left switch can be used. Use either switch in conjunction with the white reverse switch to reverse the traverse motor.

"S" Model - These switches activate brush motors and solution/control module if brush motors are in the down position.

Battery Meter (See Figure 3, Item "C")

The battery meter indicates the relative charge on the battery pack. Do not continue to run the machine when the needle is in the "red" area. This will shorten the life of the battery pack.

Brush Pressure Meter (See Figure 3, Item "D")

The pad pressure meter indicates the relative amount of pressure the pad is putting on the floor. To maximize run time on a battery charge, keep the needle towards the center of the green area.

Reverse Switch (See Figure 3, Item "E")

On Traverse Model Only

The reverse switch, when used in conjunction with one of the forward/reverse switches, causes the machine to reverse directions. The reverse speed is 70% of the forward speed.

Hour Meter (Not Illustrated) (Option)

The hour meter indicates the number of hours the machine has operated. It runs only when the brush motor is on.

Circuit Breakers (See Fig 3, Items "F", "G", "H", "I" & "J")

The circuit breaker reset buttons are located on the rear cover. The breakers are located as follows:

Item F - Actuator Head (5 amp)

Item G - Vacuum Motor (30 amp)

Item H & I - Brush Motor (40 amp)

Item J - Traverse Motor (25 amp) (L2426 only)

If a circuit breaker trips, determine which motor is not operating and turn the key switch "OFF". Wait five minutes and push the reset button back in. Turn the key switch "ON" and try again. An authorized service person should be contacted if the breaker trips again.

Control Handles (See Figure 3, Item "K")

The control handles are located at the rear of the machine. They are used to guide the machine.

Solution Control Knob (See Figure 3, Item "L")

The solution control knob regulates the flow of chemical solution to the floor. To increase the flow, turn knob clockwise. To decrease the flow, turn counter clockwise. Full counter clockwise is OFF and full clockwise is ON.

Traverse Speed Knob (See Figure 3, Item "M")

To increase speed, turn knob clockwise.

Brush Motor Switch (See Figure 3, Item "N")

To activate brush motor, push brush position switch to down position. Brush Motor and solution flow will activate when the traverse buttons are pushed. To shut brush motor off, hold brush position switch in up position until actuator stops.

Vacuum Motor Switch (See Figures 4 & 5, pg. 11)

To activate vacuum motor, lower squeegee handle. Handle has two positions. Lowest position is operating position and the middle position is transport to clear vacuum hose.

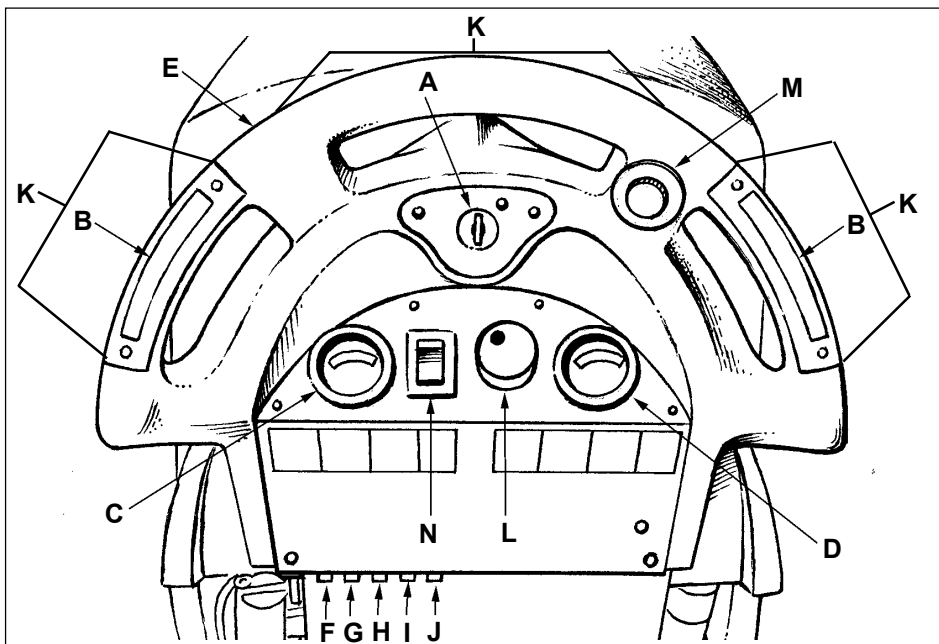

Figure 3

Machine Controls and Features

Squeegee Lift Handle, See Figures 4 and 5

The squeegee lift handle is located below the control handles in the center. It is used to raise or lower the squeegee. The vac motor is turned on when the handle is lowered to either the first or last position.

Float Shut Off, See Figure 6

The shut-off switch for the vac motor is located in the recovery tank. It automatically turns off the vac motor when the recovery tank is full. **NOTE: If excessive foaming occurs in recovery tank, defoamer must be added. Damage to vacuum motor could result from foam.**

Parking Brake (Optional), See Figure 7

NOTE: Parking Brake must be used if operating machine on greater than 2% gradient.

The parking brake prevents movement of the machine.

CAUTION: Do not activate the parking brake while the machine is moving.

"L" Model - The brake is located on the right hand side of the machine on the transaxle motor. Turn the key switch off or disconnect the power to the battery to apply the brake.

There is a mechanical lever located on the brake. This lever is an override. To manually release the brake, rotate the lever clockwise. To return the brake to normal or to apply the brake, rotate the lever up counter clockwise.

NOTE: If the lever is left in the override position, the brake will not function with the key switch, and the machine will not operate.

"S" Model - The brake is located to the left hand rear of the machine. Press pedal to activate brake and release pedal to disengage brake.

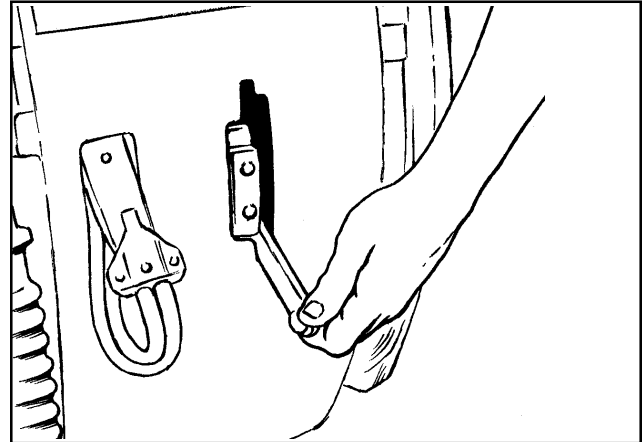

Figure 4

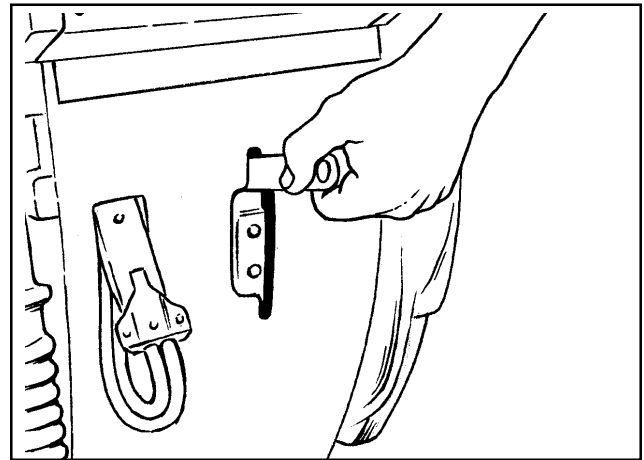

Figure 5

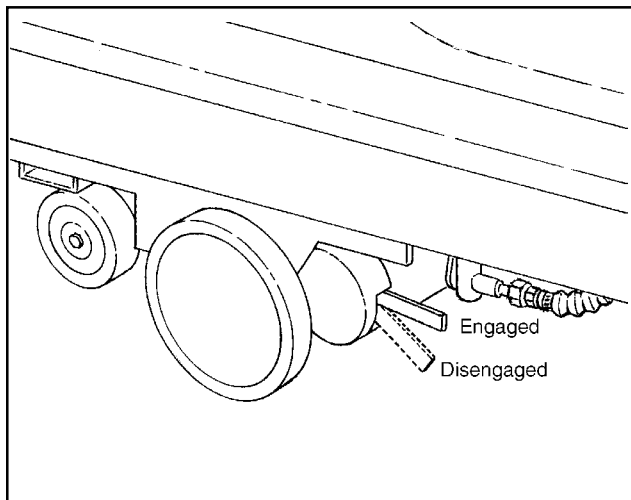

Figure 7

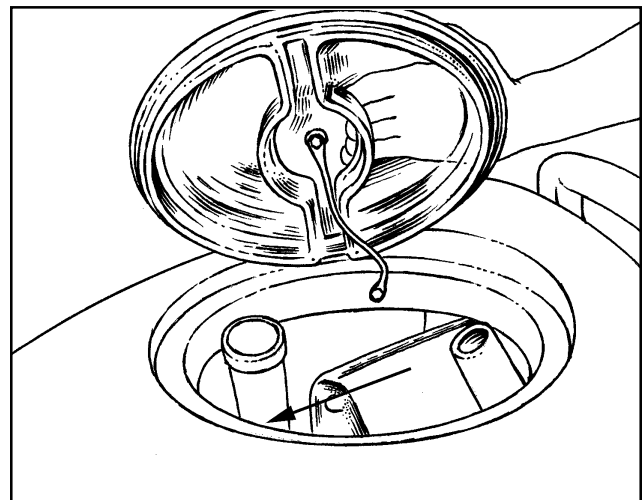

Figure 6

How To Prepare the Machine For Operation

How To Install The Batteries

The Encore machines uses either two 12-volt batteries or four - 6 volt batteries. The batteries are located in the battery compartment under the recovery tank.

To install the batteries, follow this procedure:

1. Turn machine off. Set brake (if equipped).
2. Make sure recovery tank is empty.
3. Tip up the recovery tank until it locks in the full open position. See figure 8A.

CAUTION: Before raising the tank, be sure tank is empty.

NOTE: There is an intermediate position available for holding the recovery tank open for charging batteries. See figure 8B.

WARNING: Do not operate or perform maintenance on the machine while the recovery tank is in the intermediate position. The tank can be accidentally bumped and it may slam shut.

4. Place the batteries in the tray as shown in figure 8C.

WARNING: The batteries are heavy. Lifting batteries without help could result in an injury. Get help to lift the batteries.

WARNING: Working with batteries can be dangerous. Always wear eye protection and protective clothing when working near batteries. **NO SMOKING!**

5. Connect the cables between batteries and install long battery cable assembly as indicated. See figure 8C.
6. Join the connector from the battery pack to the connector on the control panel. See figure 9.
7. Close recovery tank by pulling up on the latch arm and then slowly lowering the tank.

NOTE: Charge the batteries before using the machine.

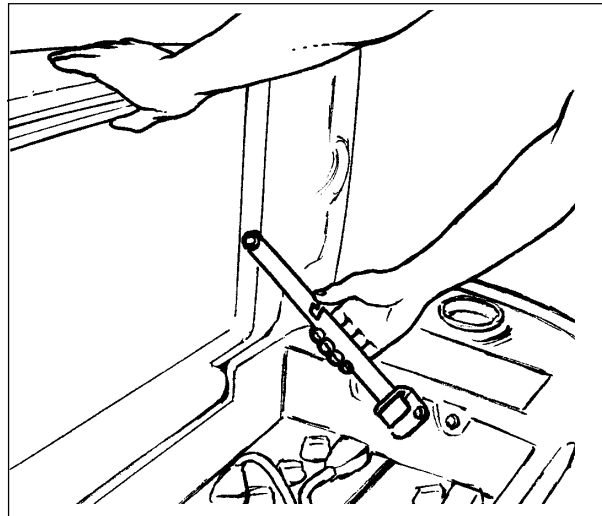

Figure 8A

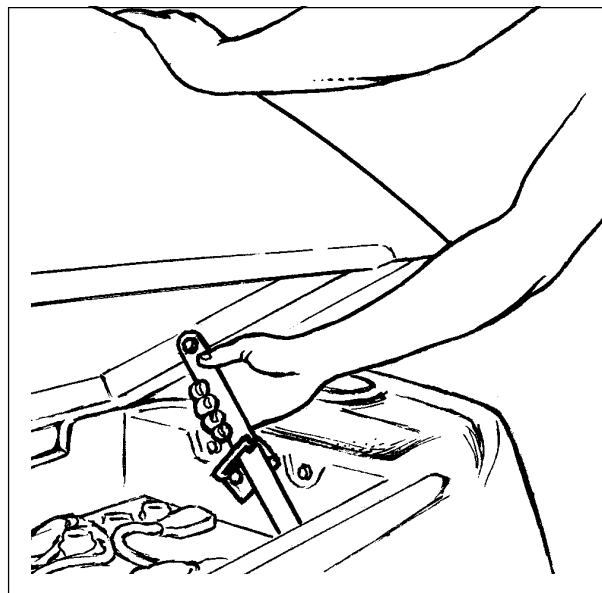

Figure 8B

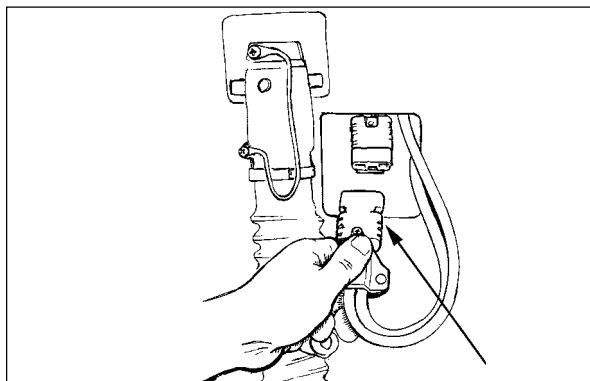

Figure 9

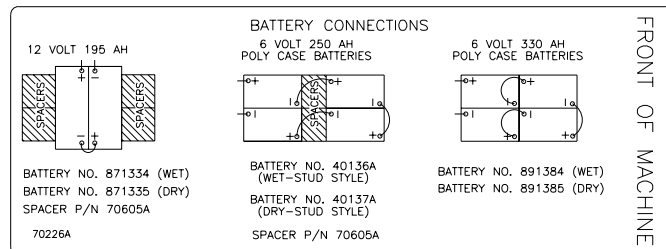

Figure 8C

How To Prepare the Machine For Operation

Battery Maintenance

The electrical power to operate the machine comes from the storage batteries. Storage batteries need preventative maintenance.

⚠ WARNING: Working with batteries can be dangerous. Always wear eye protection and protective clothing when working near batteries. **NO SMOKING!**

To maintain the batteries in good condition, follow these instructions:

1. Keep the electrolyte at the correct level. The correct level is between 1/4" (1/2 cm) below the bottom of the tube in each cell and above the tops of the plates. Check the level of the electrolyte each time you charge the batteries. See figure 10.

NOTE: Check the level of electrolyte prior to charging the batteries. Be sure the plates in each cell are covered with electrolyte before charging. Do not top off the cells prior to charging the battery. Electrolyte expands during charging. As a result, the electrolyte could overflow from the cells. Always top off the cells with distilled water after charging.

⚠ CAUTION: Irreversible damage will occur to the batteries if electrolyte does not cover the plates. Keep the electrolyte at the correct level.

⚠ CAUTION: Machine damage and discharge across the tops of the batteries can occur if the batteries are over filled. Do not fill the batteries up to the bottom of the tube in each cell. Wipe any acid from the machine or the tops of the batteries. Never add acid to a battery after installation.

⚠ CAUTION: Batteries must be refilled with distilled water only. Do not use tap water as it may contain contaminants that will damage batteries.

2. Keep the tops of the batteries clean and dry. Keep the terminals and connectors clean. To clean the top of the batteries, use a damp cloth with a weak solution of ammonia or bicarbonate of soda solution. To clean the terminals and connectors, use a terminal and connector cleaning tool. Do not allow ammonia or bicarbonate of soda to get into batteries.

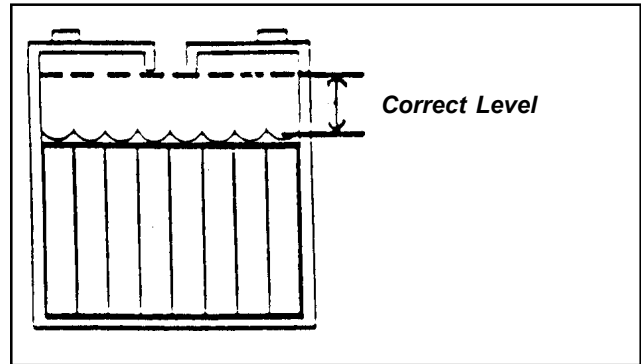

Figure 10

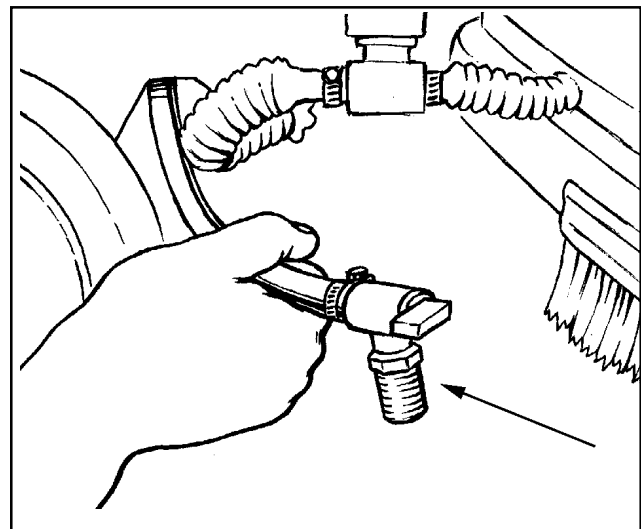

Figure 11

3. Keep the batteries charged.
4. To drain battery compartment: (See figure 11)
 - a. Always wear protective eye protection and protective clothing.
 - b. Add a weak solution of ammonia or bicarbonate of soda solution to battery compartment to neutralize any spilled acid.
 - c. Pull drain hose out from under transaxle.
 - d. Place hand behind flange and open valve.
 - e. When empty, close valve.
 - f. Replace valve and drain hose on top of transaxle.
 - g. Neutralize any acid spills with ammonia or bicarbonate of soda.

How To Prepare the Machine For Operation

How To Charge The Batteries

- ⚠ WARNING:** Charging the batteries in an area without adequate ventilation could result in an explosion. To prevent an explosion, charge the batteries only in an area with good ventilation.
- ⚠ WARNING:** Lead acid batteries generate gases which could explode. Keep sparks and flames away from batteries. **NO SMOKING!**
- ⚠ WARNING:** Failure to disconnect the AC plug from the wall receptacle before connecting or disconnecting the DC connector on the charger could result in an explosion. Always disconnect the AC plug from the wall receptacle before connecting or disconnecting the DC connector on the charger.

To charge the batteries, follow this procedure:

1. Put the charger on a flat surface. Make sure the vents on the sides are at least two inches away from walls and other objects. Make sure there are no objects near the vents on the bottom of the charger.
2. "L" Model - when key is off, brake is activated. Make sure key is off.

"S" Model - Set the parking brake (if provided) by putting it into the down position. See figure 12. Make sure the key switch is in "OFF" position.

3. Before charging the batteries the battery compartment needs to be vented. To vent compartment, tip up the recovery tank until it locks in either of the two open positions. See figure 13A. To close the tank, pull up on the latch arm and then slowly lower the tank to the closed position.

- ⚠ CAUTION:** Before raising tank, be sure tank is empty.

NOTE: There is an intermediate position available for holding the recovery tank open for charging batteries. See figure 13B.

- ⚠ WARNING:** Do not operate or perform maintenance on the machine while the recovery tank is in the intermediate position. The tank can be accidentally bumped and it may slam shut.

To place the tank in the intermediate position, pull up on the latch arm while raising the recovery tank until it slips into the knotch area of arm. While pulling up on the latch arm, carefully lower the recovery tank making sure it is securely locked into place. See figure 13B. To release the latch arm, tip the recovery tank up slightly while pushing down on the latch arm and then slowly lower the tank.

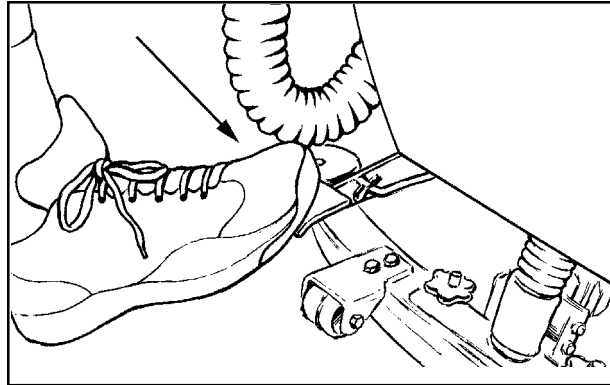

Figure 12
("S" Model)

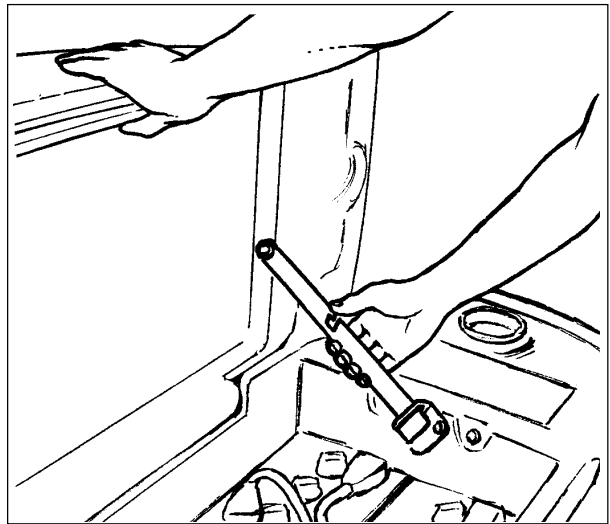

Figure 13A

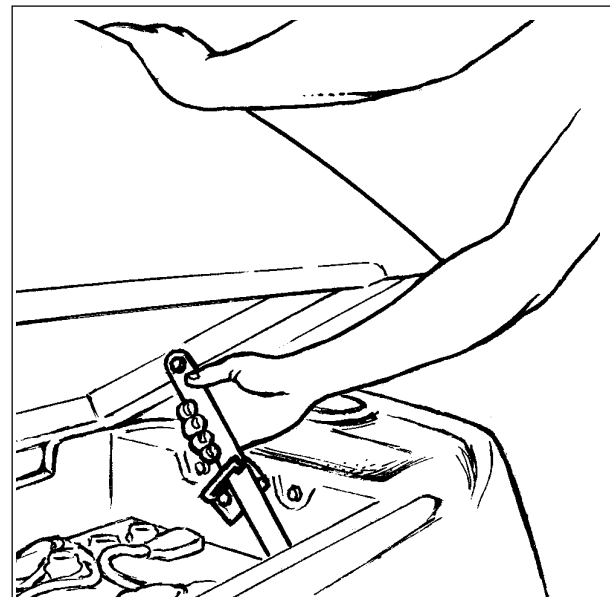

Figure 13B

How To Prepare the Machine For Operation

4. Disconnect the battery pack connector from the control housing connector. See figure 14A.
5. Connect the DC connector on the charger to the battery pack connector. See figure 14B.
6. Connect the charger to a properly grounded single phase (3-wire) wall receptacle having the input voltage, frequency, and ampere capacity specified on the nameplate of the charger.

For more information on the use of the charger, read the instructions supplied with the charger.

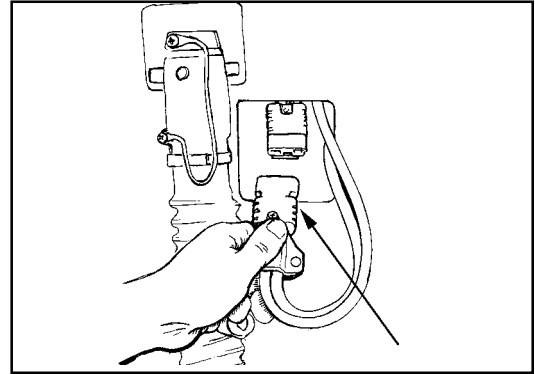

Figure 14A

How To Adjust Brush Cleaning Path from 24" to 26"

1. Insure brush head is in up position.
2. Turn the key switch "OFF" and remove the key.
3. Open front cover.
4. Raise plunger pin and rotate brush head. See figure 15.
5. Insure plunger pin is engaged in brush plate.
6. Close front cover.

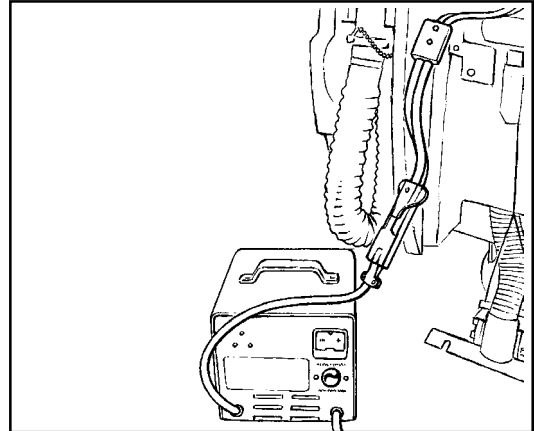

Figure 14B

How To Install The Brushes Or Pad Drivers

To install the brushes or pad drivers on the machine, follow this procedure:

1. Turn the key switch "ON".
2. Raise the brush head by pressing and holding the brush switch until brush head is in its full up position.
3. Turn the key switch "OFF" and remove the key.
4. Go to the front of the machine and unlatch front cover, swing cover open.
5. Unlatch right and left brush housings and remove them. See figure 16.
6. Put a brush or pad driver under the brush motor plate. See figure 17.
7. ("L" Model) Align the lugs on the motor gimbal with the slots in the brush gimbal.
("S" Model) Align the lugs on the motor with the slots on the brush gimbal.
8. ("L" Model) Pull the brush up until the gimbal locks.
("S" Model) Pull the brush up and rotate counter direction to scrub rotation, until lugs lock.
9. Repeat steps 6, 7, and 8 to install the second brush or pad driver.
10. Reinstall right and left brush housings and latch front cover.

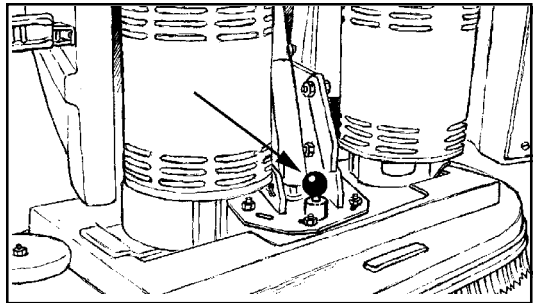

Figure 15

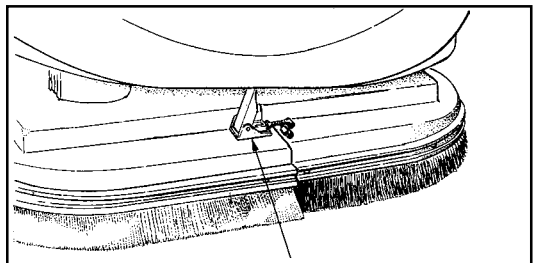

Figure 16

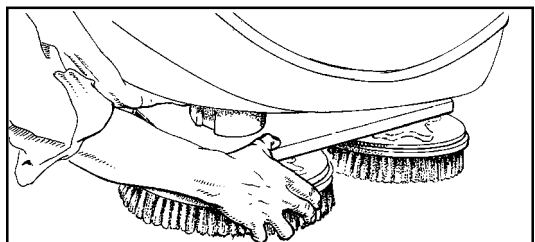

Figure 17

⚠ DANGER: Operating a machine that is not completely or fully assembled could result in injury or property damage. Do not operate this machine unless it is completely assembled. Inspect the machine carefully before operation.

How To Prepare the Machine For Operation

How To Remove The Brushes Or Pad Drivers

To remove the brushes or pad drivers from the machine, follow this procedure:

1. Turn the key switch "ON".
2. Raise the brush head by pressing and holding the brush switch until brush head is in its full up position.
3. Turn the key switch "OFF" and remove the key.
4. Go to the front of the machine and unlatch front cover. Swing cover open and unlatch the brush housings.
5. ("L" Model) Push down on two sides of the brush or pad driver until the gimbals release.

("S" Model) Rotate brush same direction to scrub rotation with a quick snapping action until brush releases.

6. Reinstall right and left brush housing and latch front cover.

⚠ DANGER: Operating a machine that is not completely or fully assembled could result in injury or property damage. Do not operate this machine unless it is completely assembled. Inspect the machine carefully before operation.

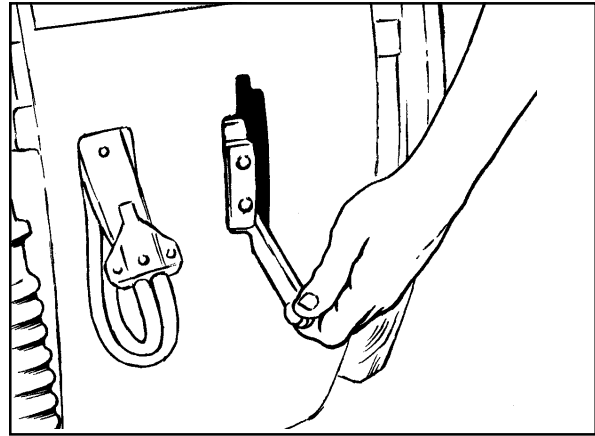

Figure 18

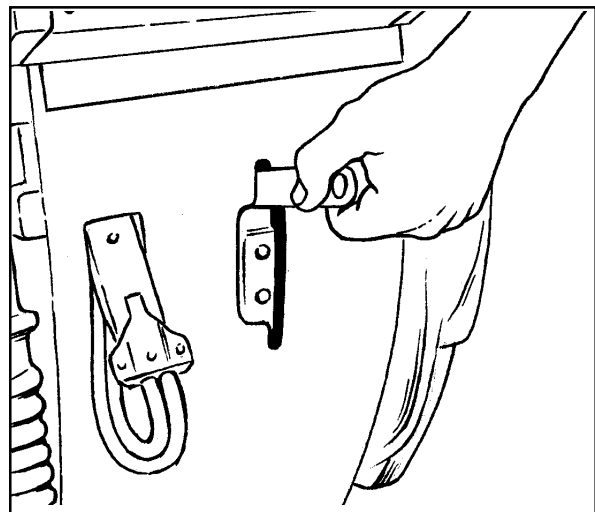

Figure 19

How To Operate The Machine

How To Operate The Squeegee

The squeegee wipes the floor while the vacuum motor removes the dirty solution from the floor. Use your hand to lower or raise the squeegee handle. To operate the squeegee, follow this procedure:

1. To lower the squeegee and start the vacuum motor, move the squeegee lever to the right and down. See figure 18.
2. To raise the squeegee, lift the squeegee lever up. See figure 19.

NOTE: The center position lets the vacuum motor continue to run with the squeegee off the floor to avoid drips and also allows you to back up the machine.

How To Fill The Solution Tank

The solution tank can be filled in the front or through the clear drain hose at the rear of the machine (See figure 20). To fill the solution tank follow this procedure:

1. Add a cleaning chemical to the solution tank. For the correct amount of chemical, follow the directions shown on the container.
2. Fill the solution tank with water. When filling machine in the front with a hose, position hose inside the fill screen as shown in figure 20A.

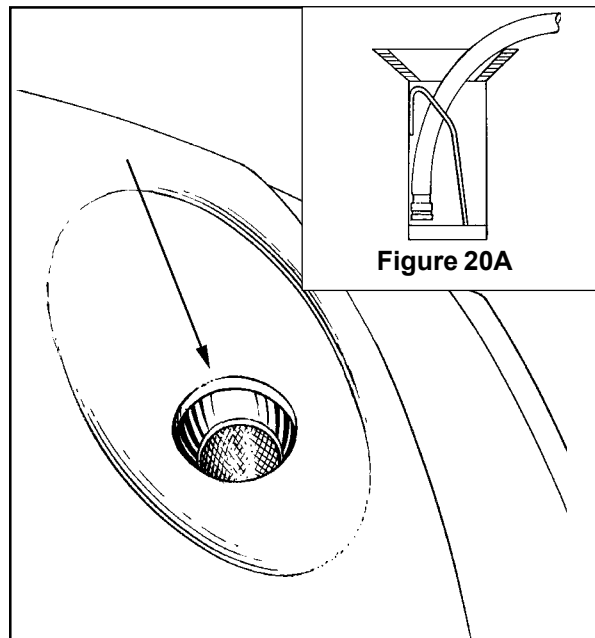

Figure 20A

Figure 20

How To Operate The Machine

When filling machine from the rear, position clear drain hose against bracket and insert hose as shown in figure 20B. Solution level can be viewed from the back of the machine.

⚠ WARNING: Water solutions or cleaning materials used with this type of machine can leave wet areas on the floor surface. These areas can cause a dangerous condition for the operator or other persons. Always put CAUTION signs near the area you are cleaning.

⚠ WARNING: Machines can ignite flammable materials and vapors. Do not use with or near flammables such as gasoline, grain dust, solvents and thinners. Only use a cleaning concentration recommended by the chemical manufacturer.

⚠ WARNING: Clarke Technology recommends a maximum water temperature of 120°F (49°C).

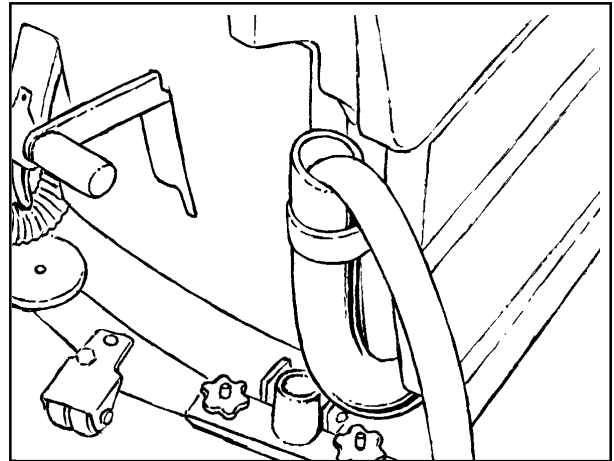

Figure 20B

Operating The Machine

NOTE: Put the machine in the lowest traverse speed setting. Use the machine in an area that has no furniture or objects until you can do the following:

1. Move the machine in a straight direction, forward and backward.
2. Stop the machine safely.
3. Turn the machine both left and right and return to a straight direction.

To move the machine, follow this procedure:

1. Release the parking brake (if equipped with machine).
2. Turn the key switch to the "ON" position
3. Raise the brush to the highest setting.
4. Raise the squeegee.
5. When either the left or right forward/reverse switches (figure 21, item A) are pushed in, the machine will go forward.
6. Control the speed of traverse by using the traverse speed control knob (figure 21, Item C).
7. To stop, release the forward/reverse switch.
8. To reverse the machine, push in the white reverse switch (figure 21 item B) and either the right or left forward/reverse switch (figure 21 item A) at the same time.
9. To stop, release the forward/reverse switch.
10. To turn the machine, push the rear of the machine to the side.
11. When you stop the machine, turn the key switch "OFF", remove the key and set the parking brake (if equipped).

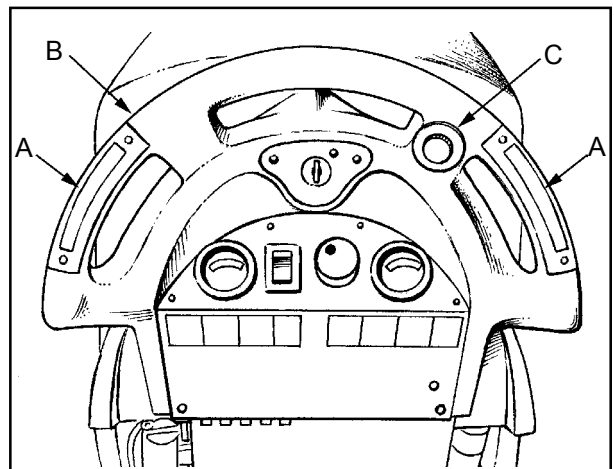



Figure 21

How To Operate The Machine (cont)

How To Clean A Floor

 **WARNING:** Water solutions or cleaning materials used with this type of machine can leave wet areas on the floor surfaces. These areas can cause a dangerous condition for the operator or other persons. Always put CAUTION signs near the area you are cleaning.

To clean a floor follow this procedure:

1. Set the parking brake (if equipped with machine.)
2. Put the water and a cleaning chemical in the clean solution tank.
3. Release the parking brake (if equipped with machine.)
4. Turn the key switch "ON".
5. Lower the squeegee.
6. Activate the brush switch until correct pressure is achieved.

 **WARNING:** This machine is capable of maximum head pressure with worn pads or brushes. With this feature, there is the possibility of exceeding the recommended brush pressure on new pads or brushes. This will either create reoccurring circuit breaker tripping or the possibility of lost traction and control. The brush switch should be activated to accomplish only enough brush pressure for the job. This will allow longer battery life and cleaning time.

NOTE: Keep the machine moving when the brush is rotating on the floor. Pre-wet brush/pad or keep light pressure on brush until solution flow is adequate to keep brush/pad from scratching the floor.

To pre-wet brushes you should first turn the speed knob to the lowest setting on the "L" model. Then on both the "S" and "L" models, lower brushes until brushes are just touching the floor. Activate the forward/reverse switch to start motor and solution flow.

7. Turn the solution knob to the right to activate the flow of solution. Adjust the flow of clean solution to the flow desired.
8. Move the machine across the floor in the forward direction.
9. Make a 180° turn.

NOTE: When you make more passes across the floor, let the brush clean approximately 2 inches (5 cm) of the area already cleaned by the brush.

NOTE: During most cleaning procedures, apply and remove the solution in one operation.

How To Clean A Very Dirty Floor

To clean a very dirty floor, follow this procedure:

1. Apply solution to the floor.
2. Do not lower the squeegee. This will keep the vacuum motor off.
3. Lower the brush or pad and scrub the floor.
4. Scrub the floor again with additional solution and lower the squeegee.
5. Pick up all the solution with the squeegee.

Maintenance

⚠ WARNING: Maintenance and repairs must be done by authorized personnel only.

⚠ WARNING: Always empty the solution tank and recovery tank before doing any maintenance.

⚠ WARNING: Keep all fasteners tight.

These Maintenance Procedures Must Be Done Every Day

Keep the machine clean, it will need fewer repairs and have longer life.

Do These Procedures When You Begin Your Work Period

1. Turn off key switch.
2. Disconnect AC power from battery charger (follow charger instructions).
2. Disconnect the plug on the battery charger from the battery pack connector.
3. Join the connector from the batteries to the control panel cable connection. See figure 22.
4. Make sure the Screen filter over the vacuum motor is clean and in position. See figure 24.
5. Make sure the recovery tank lid is on correctly. See figure 23, Item A.
6. Make sure the valve on the recovery drain hose is clean. Tightly close the valve.
7. Make sure the brushes/pads are in position and installed correctly.
8. Make sure brush housings and skirts are in position on the brush head.
9. Check the installation of the squeegee and squeegee hose.
10. Make sure the solution drain / level indicator hose is secure on the storage mount on the rear of the machine.

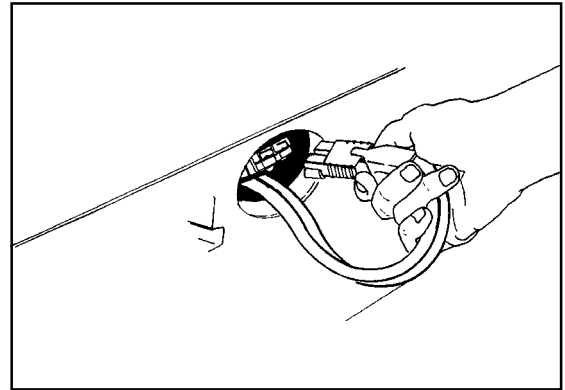

Figure 22

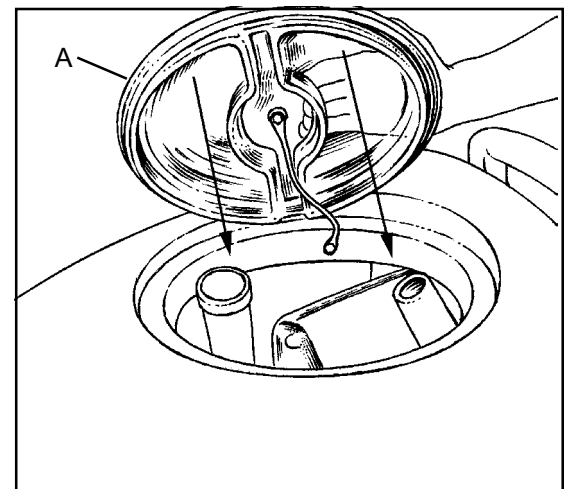

Figure 23

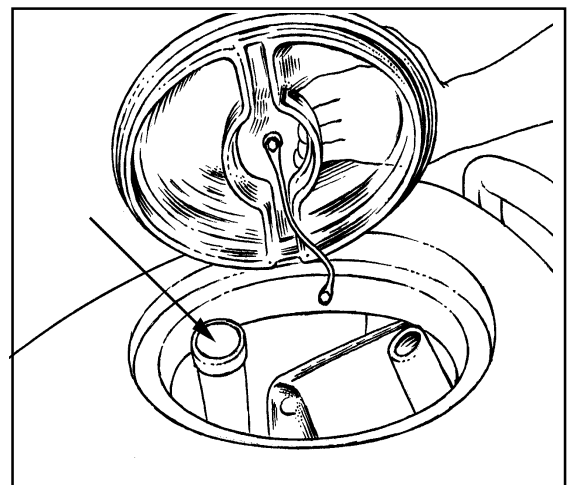

Figure 24

Maintenance

Do These Procedures When You End Your Work

1. Drain the solution tank (Figure 25) and the recovery tank (Figure 26). To drain the tanks, follow this procedure:
 - a. Turn the key switch "OFF".
 - b. Remove the drain hose from the back of the machine.
 - c. Put the end of the hose over a drain or bucket.
 - d. *Recovery Tank:*
 - 1.) Turn the valve handle to the left. Pull the handle out to open the drain (Figure 27).

NOTE: Have the opening in the side of the valve away from you when you open the valve.

- 2.) To open the valve completely, turn the handle to the right. Pull the handle out of valve (Figure 28).

Solution Tank:

When hose is lowered to water level, water will flow.

2. Flush the tanks. To flush the tanks, put clean water in the tank through the opening on top of the tank.
3. If a tank or drain hose has an obstruction, use a pressure water hose to flush the tank or hose. Put the water hose into the drain hose.
4. Leave the tanks and the recovery drain valve open to dry in the air.
5. Check the squeegee blade. Use a cloth to clean the squeegee blade. If the squeegee blade is damaged or worn, turn or replace the blade.
6. Check and clean the solution lid gasket. Use a mild cleaning solution and rinse the parts in clean water.

Check the batteries and if necessary add distilled water after charging. The correct level is within 1/4 inch (1/2 cm) of the bottom of the tube in each cell.

CAUTION: Tap water may contain contaminants that will damage batteries. Batteries must be refilled with **DISTILLED WATER ONLY**.

WARNING: Lead acid batteries generate gases which can cause an explosion. **NO SMOKING.** Always wear eye protection and protective clothing when working near batteries.

Use a clean cloth and wipe the surface of the machine.

Charge the batteries. See the instruction in the section of this book called "How To Charge The Batteries".

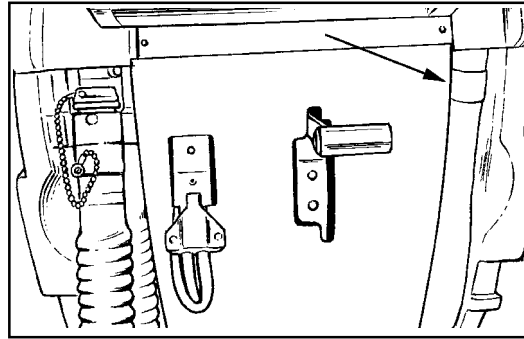

Figure 25

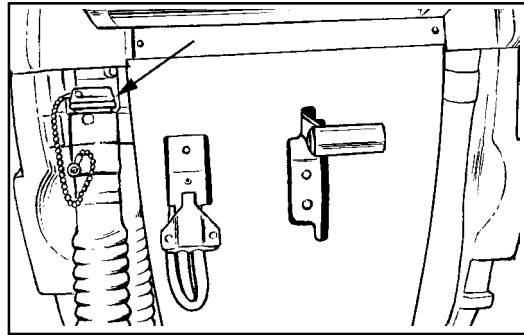

Figure 26

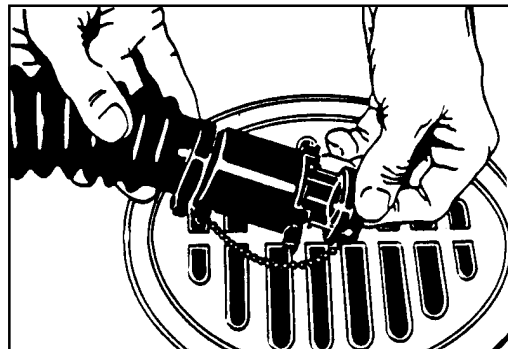

Figure 27

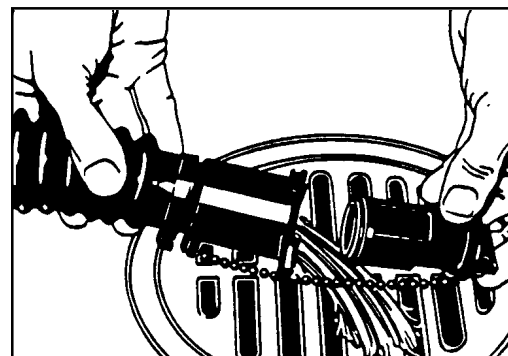

Figure 28

Maintenance

Maintenance Procedures To Be Done Every Week:

⚠ WARNING: Maintenance and repairs must be done by authorized personnel only. Always empty the solution tank and the recovery tank before doing any maintenance. Keep all fasteners tight.

⚠ WARNING: Always wear eye protection and protective clothing when working near batteries. Do not put tools or other metal objects across the battery terminals or the tops of the batteries.

⚠ CAUTION: To prevent damage to the machine, and discharge across the tops of the batteries, do not fill the batteries above the bottom of the tube in each cell. Wipe any acid from the machine or the tops of the batteries. Do not add acid to battery after installation.

NOTE: Always turn off key switch before servicing the machine.

⚠ WARNING: Always wear eye protection and protective clothing when working near batteries. **NO SMOKING!**

1. To inspect batteries, tip up recovery tank until it locks in the full open position. See figure 29A. To close the tank, pull up on the latch arm and then slowly lower the tank to the closed position.

⚠ CAUTION: Before raising the tank, be sure tank is empty.

NOTE: There is an intermediate position available for holding the recovery tank open for charging batteries. See figure 29B.

⚠ WARNING: Do not operate or perform maintenance on the machine while the recovery tank is in the intermediate position. The tank can be accidentally bumped and it may slam shut.

2. Disconnect the batteries. Use a cloth and a solution of ammonia or bicarbonate of soda to wipe the top of the batteries. Clean the battery terminals. Reconnect the batteries.
3. Check the hoses for leaks, obstructions and other damage.
4. Check and clean the filter screen in the solution hose. To clean the screen, follow this procedure:
 - a. Close the solution flow valve.
 - b. Turn the connector to the left.
 - c. Remove and clean the filter screen.
 - d. Install the filter screen in the valve connector. Turn the connector to the right to connect the hose. See figure 34
 - e. Open the solution flow valve. See figure 34.

5. Use a grease gun to lubricate the dual casters. See figure 30.

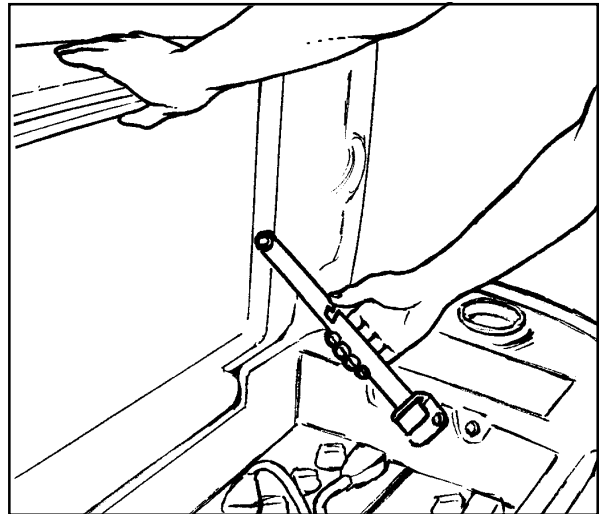

Figure 29A

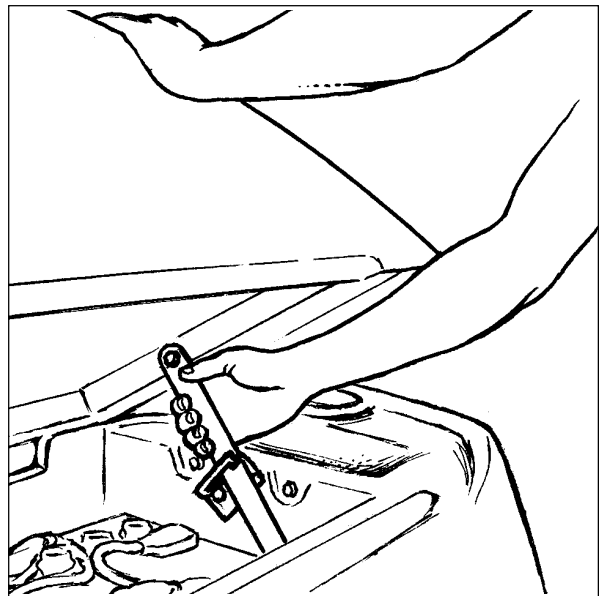

Figure 29B

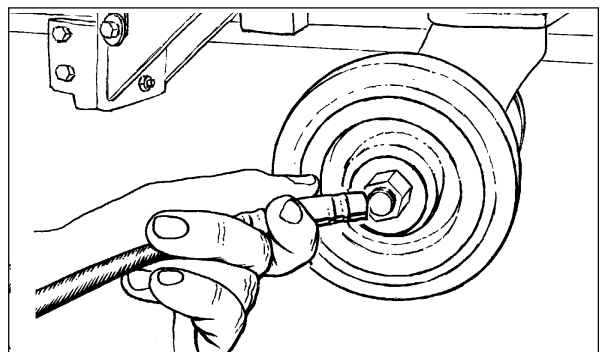

Figure 30

Maintenance

Maintenance For The Squeegee

To remove the squeegee, follow this procedure:

1. Remove the squeegee assembly by loosening the two knobs that attach the squeegee to the machine. Pull the squeegee assembly off. See figure 31.
2. Inspect the squeegee blade.
3. If the blade is worn, turn the blade so that a new edge is in the wiping position.
4. Reinstall squeegee assembly on the machine.

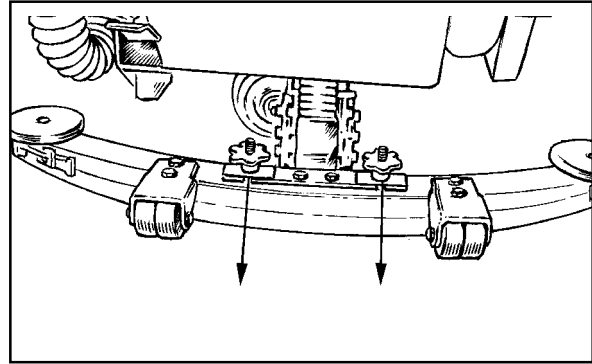

Figure 31

How To Adjust The Squeegee

The following adjustments are set at the factory, however they may require slight adjustment.

Adjusting Squeegee Tilt:

The tilt of the squeegee causes the rear blade to raise up in the center or on the ends, depending on which direction the tilt is changed. For tilt adjustment, refer to figure 32. Loosen left and right screw "X". In order to bring the blades down in the center, tip "Y" down. To bring both ends down, tip "Y" up. Make very small adjustments and try it until a uniform flare is achieved.

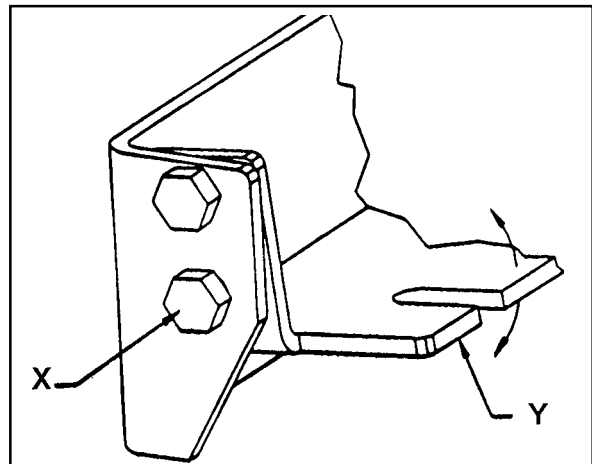

Figure 32

Adjusting Squeegee Blades:

When properly installed the front blade should be approximately 0.06" (1.5mm) above the rear blade. See figure 33.

⚠ WARNING: Maintenance and repairs must be done by authorized personnel only .

⚠ WARNING: Electrical repairs must be done by authorized personnel only.

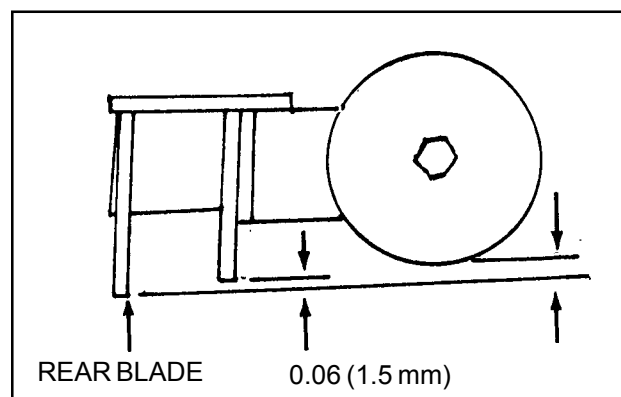

Figure 33

Maintenance cont.

Consult your Clarke Technology Authorized Service Person to do the service procedures.

Use only genuine Clarke Technology parts.

How to Clean the Solution Line

If the solution line becomes clogged follow this procedure:

1. Turn key switch "OFF" and remove the key.
2. Open brush motor cover and remove brush housing.
3. Remove brushes / pads.
4. Locate the solution valve. It is located behind the brush motor.
5. Turn solution valve "OFF". See figure 34, A)
6. Locate the solution filter screen. It is located on the back of the solution valve. See figure 34, B)
7. Unscrew the female garden hose connector from the back of the solution valve. The filter screen is in the female connector.
8. Remove the filter screen. See figure 34.
9. Clean and replace screen.
10. Attach the female garden hose connector to the solution valve.
11. Turn solution valve to "ON".

How to Center or Offset the Brush Head

The brush head on the Encore 2426 can be centered or offset 1 inch to the right side of the machine. To center or offset the brush head, follow this procedure:

Recommended tools: 3/8" drive ratchet, 3" extension and 9/16" socket.

CAUTION: Before offsetting the brush head, be sure that the recovery tank is empty of solution. Follow the instructions on page 20 on how to drain the recovery tank.

1. Turn the key switch "ON".
2. Raise the brush head by pressing and holding the brush switch until the brush head is in its full up position.

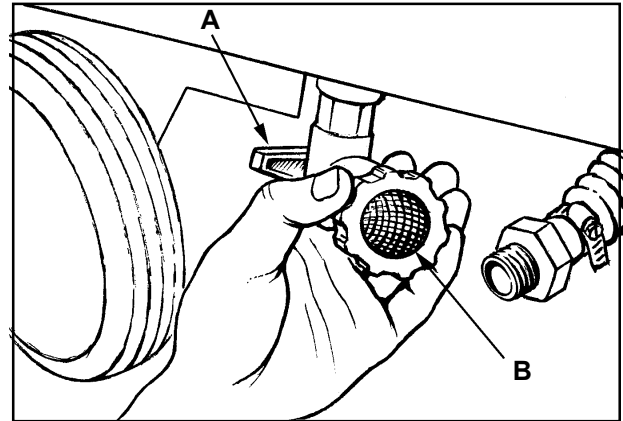

Figure 34

Maintenance cont.

3. Turn the key switch "OFF" and remove the key.
4. Tip up the recovery tank until it locks in the full open position.
5. Go to the front of the machine and unlatch the front cover and swing cover open.
6. Locate the four mounting studs on the brush head bracket. See figure 35. The top two mounting nuts can be accessed through the top of the solution tank. The lower two can be accessed through the front. Loosen the four mounting nuts 2 to 3 turns counterclockwise. NOTE: Do not remove mounting nuts.
7. The brush head assembly can slide to the right side by one inch or placed back into the center. Slide the brush head assembly all the way to the ends of the slots for the desired position. This insures that the head operates straight up and down.
8. After repositioning the brush head, tighten nuts securely to approximately 236 inch-lbs.
9. Close the front cover.
10. Close the recovery tank.

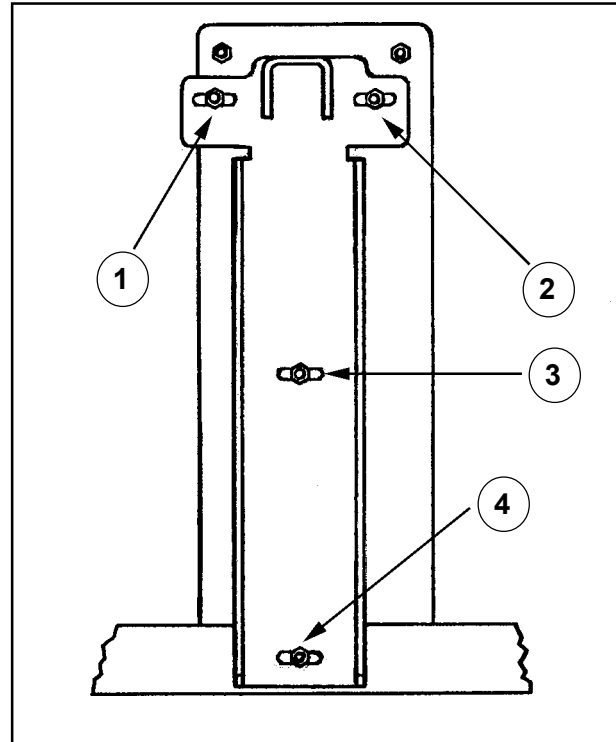

Figure 35

Clarke Technology
Encore S2426 and L2426
Accessories - 5/01

ACCESSORIES

Description	Part No.
Power Wand System Kit	10150A
Clarke Care Kit	14607A
39" Squeegee Assembly	10068A
32" Squeegee Assembly	10129A
Poly Dur Protectant	50478A
Kit, Grease Gun	55420A
Kit, Low Voltage Shut-Off	14097A
Brake Kit Assembly "L"	10072A
Brake Kit Assembly "S"	10073A
Accessory Bag	30070A
Hour Meter Kit	10656A
Soft Caster Assembly	51092A
Gimbal, Brush "L"	833802◆
Gimbal, Brush Spring "L"	838301◆
Dual Direct Clutch Plate "S"	30034A◆
Spacer for 30034A Clutch Plate "S"	10143A◆
Center Lock Pad Retainer	56941A◆
Kit, Solution Fill	10177A◆

Brushes and Pad Assemblies:

Size	Description	Part No. (Gimbal "L")	Part No. (Clutch "S")	Used For
13"	Polypropylene	11438A	10141A	General Scrubbing Hard Floors
13"	Pad Driver Asm.	17531A	10140A	Use for Pads
13"	Clean Grit	11439A	10152A	
13"	Super Grit	11440A	10153A	
13"	Nylon Soft	11437A	10154A	

Squeegee Blades:

Description	32" Assembly	39" Assembly
Blade, Rear - Gum Rubber	30067A	30069A
Blade, Rear - Nitrile Solid	30081A	30082A
Blade, Rear - Ribbed Orange	30085A	30086A
Blade, Front - Ribbed Natural	30066A	30091A
Blade, Front - Slit Grout	30079A	30080A
Blade, Front - Ribbed Orange	30083A	30084A

NOTE: ◆ indicates a change has been made since last publication of this manual.



ENCORE
S2426 and L2426
Section II
Parts and Service Manual

(70200A)

HOW TO CORRECT PROBLEMS IN THE MACHINE

PROBLEM	CAUSE	ACTION
There is no solution flow.	<p>The solution tank is empty.</p> <p>The solution valve is closed.</p> <p>There is an obstruction in the solution hose or filter.</p> <p>The solution valve or electric wiring is damaged.</p> <p>The solution module is defective.</p>	<p>Fill the solution tank.</p> <p>Open the solution valve.</p> <p>Remove the obstruction from the hose or filter.</p> <p>Repair or replace the valve or the electric wiring.</p> <p>Replace solution module</p>
The solution flow does not stop.	<p>The solution valve is open.</p> <p>The solution valve or wiring is damaged.</p> <p>The solution valve is dirty</p> <p>There is a damaged seat and washer in the solution valve.</p> <p>The solution module is defective.</p>	<p>Close or Clean the solution valve.</p> <p>Repair or replace the valve and the wiring.</p> <p>Clean the solution valve.</p> <p>Replace the seat and washer.</p> <p>Replace solution module.</p>
The machine does not remove all the water from the floor.	<p>The squeegee is up.</p> <p>The squeegee tilt is not correct.</p> <p>The recovery tank is full.</p> <p>The screen filter is dirty.</p> <p>There is an obstruction or damage in the squeegee, squeegee hose or standpipe.</p> <p>The vacuum motor is not running.</p> <p>The squeegee hose is disconnected, or damaged</p> <p>The squeegee blade is damaged, worn, or incorrectly installed.</p> <p>The gaskets on the cover of the recovery tank are damaged.</p>	<p>Lower the squeegee.</p> <p>To adjust See Figure 11, page 23.</p> <p>Drain the recovery tank.</p> <p>Clean the screen filter.</p> <p>Remove the obstruction or repair the damage.</p> <p>Check for tripped breaker. Have an authorized service person make repairs.</p> <p>Check and connect hose.</p> <p>Turn or replace the squeegee blade. Correctly install the squeegee blade.</p> <p>Replace the gaskets.</p>
The batteries do not give the normal running time.	<p>The battery terminals are dirty or damaged.</p> <p>The electrolyte level is too low.</p> <p>The batteries are not fully charged.</p> <p>The charger is damaged.</p> <p>The battery is defective.</p> <p>The batteries are disconnected.</p> <p>Brush is in heavy scrub setting.</p>	<p>Clean the terminals and connectors. Replace the damaged cables. Charge the batteries.</p> <p>Add distilled water to each cell and charge the batteries.</p> <p>Charge the batteries for a full 16 hour charge.</p> <p>Have an authorized service person repair the charger.</p> <p>Check voltage of each cell while discharging.</p> <p>Connect the batteries.</p> <p>Adjust Pressure.</p>

PROBLEM	CAUSE	ACTION
<p>The cleaning is not even.</p>	<p>The scrub brush or pad is worn.</p> <p>There is damage to the brush assembly, caster or the solution valve.</p> <p>The brush motor is not running</p> <p>The solution level is low.</p>	<p>Replace the scrub brush or pad.</p> <p>Have an authorized service person make the needed repairs.</p> <p>Check for tripped breaker. Reset. Check for loose connections.</p> <p>Fill the solution tank.</p> <p>NOTE: If the problem continues consult an authorized service person.</p>
<p>The machine does not run.</p>	<p>The machine loses power.</p> <p>Key or switch is off.</p> <p>Batteries are unplugged. Battery terminals are dirty.</p> <p>Batteries are discharged</p>	<p>Reset the circuit breaker.</p> <p>Turn key or switch on.</p> <p>Check the battery connections.</p> <p>Check battery gauge and recharge</p> <p>NOTE: If the problem continues consult an authorized service person.</p>

CLARKE TECHNOLOGY
Encore S2426/L2426
Final Assembly Drawing 11/23/00

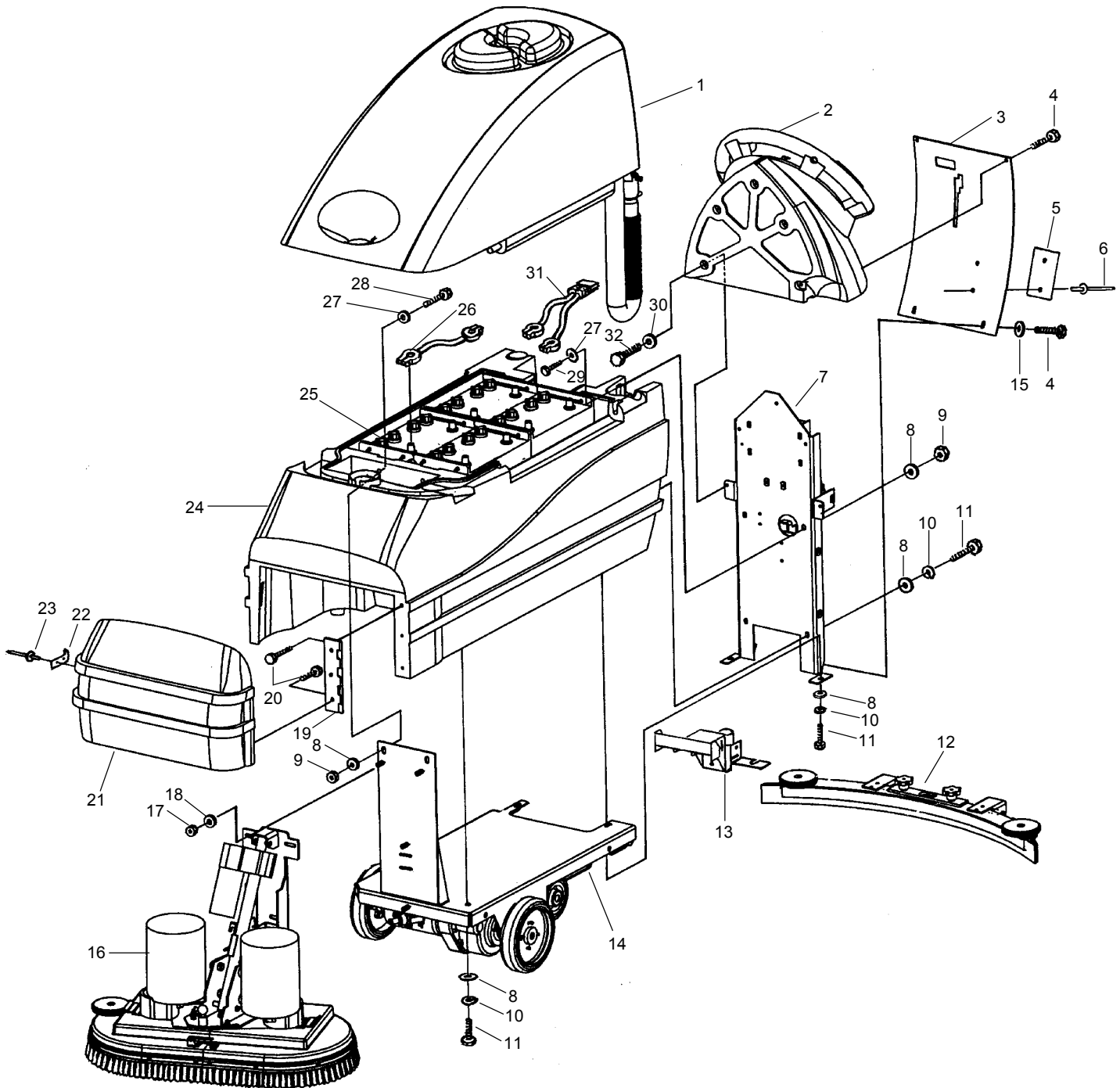

CLARKE TECHNOLOGY
Encore S2426/L2426
Final Assembly Parts List 11/23/00

Ref. #	Part No.	Description	Qty "L"	Qty "S"
1	10062A	Assembly, Recovery Tank	1	1
2	10065A	Assembly, Control Panel "L"	1	-
	10066A	Assembly, Control Panel "S"	-	1
3	30064A	Rear Cover	1	1
4	80108A	Screw, 10-24 x 1/2 SS	4	4
5	70080A	Plate, Warning	1	1
6	83010A	Rivet, Pop 1/8	2	2
7	10064A	Assembly, Rear Panel "L"	1	-
	10067A	Assembly, Rear Panel "S"	-	1
8	980651	Washer, 5/16 Flat	11	11
9	920110	Nut, 5/16 -18 ESNA	4	4
10	980652	Washer, 5/16 Lock	7	7
11	85811A	Screw, 5/16 -18 x 3/4	7	7
12	10129A	Assembly, Squeegee 32"	1	1
13	10075A	Assembly, Squeegee Lift	1	1
14	10069A	Assembly, Traverse System "L"	1	-
	10070A	Assembly, Non-Traverse System "S"	-	1
15	980982	Washer #10	2	2
16	10071A	Assembly, Brush Head "L"	1	-
	10061A	Assembly, Brush Head "S"	-	1
17	81105A	Nut, 3/8-16 ESNA	4	4
18	87031A	Washer, 3/8 Flat SS	4	4
19	50965A	Hinge	1	1
20	85395A	Screw, 1/4-20 x 1/2 SS	6	6
21	30059A	Front Cover	1	1
22	50966A	Latch, Front Cover	Ref	Ref
23	930090	Rivet, 5/32 X 9/16	2	2
24	10063A	Assembly, Solution Tank	1	1
25*	Page 12	Battery		
	871334	Battery 12V, 195 AH (wet - UT Post)	-	2
	871335	Battery 12V, 195 AH (dry - UT Post)	-	2
	40136A	Battery 6V, 250 AH (wet - Stud Post)	4	4
	40137A	Battery 6V, 250 AH (dry - Stud Post)	4	4
	891384	Battery, 6V 330 AH (wet - UT Post)	4	4
	891385	Battery, 6V 330 AH (dry - UT Post)	4	4
26	41206A	Series Battery Cable (Taper Style)	3	3
	41217A	Series Battery Cable (Ring Style)	3	3
27	980205	Washer, 5/16 Fender	4	4
28	85734A	Screw, 5/16-18 x 2	2	2
29	85739A	Screw, 5/16-18 x 3 Hex	2	2
30	87026A	Washer, 1/4 flat SS	5	5
31	41211A	Battery, Cable (Taper Style)	1	1
	40174A	Battery, Cable (Ring Style)	1	1
32	85518A	Screw, 1/4-20 x 3/4	5	5
NI	10132A	Lit Kit	1	1
NI	17531A	Pad Driver Assembly	1	-
	10140A	Pad Driver Assembly	-	1
NI	40512A	Battery charger	1	1
NI	77092A	Label, Gases	1	1
NI	77093A	Label, Falling	1	1
NI	70226A	Label, Battery	1	1
NI	30070A	Accessory Bag	1	1
NI	10072A	Parking Brake Assembly "L"	1	-
NI	10073A	Parking Brake Assembly "S"	-	1

* See page 12 for installation.

CLARKETECHNOLOGY
 Encore S2426/L2426
 Recovery Tank Assembly Drawing 8/00
 Drawing #10062A

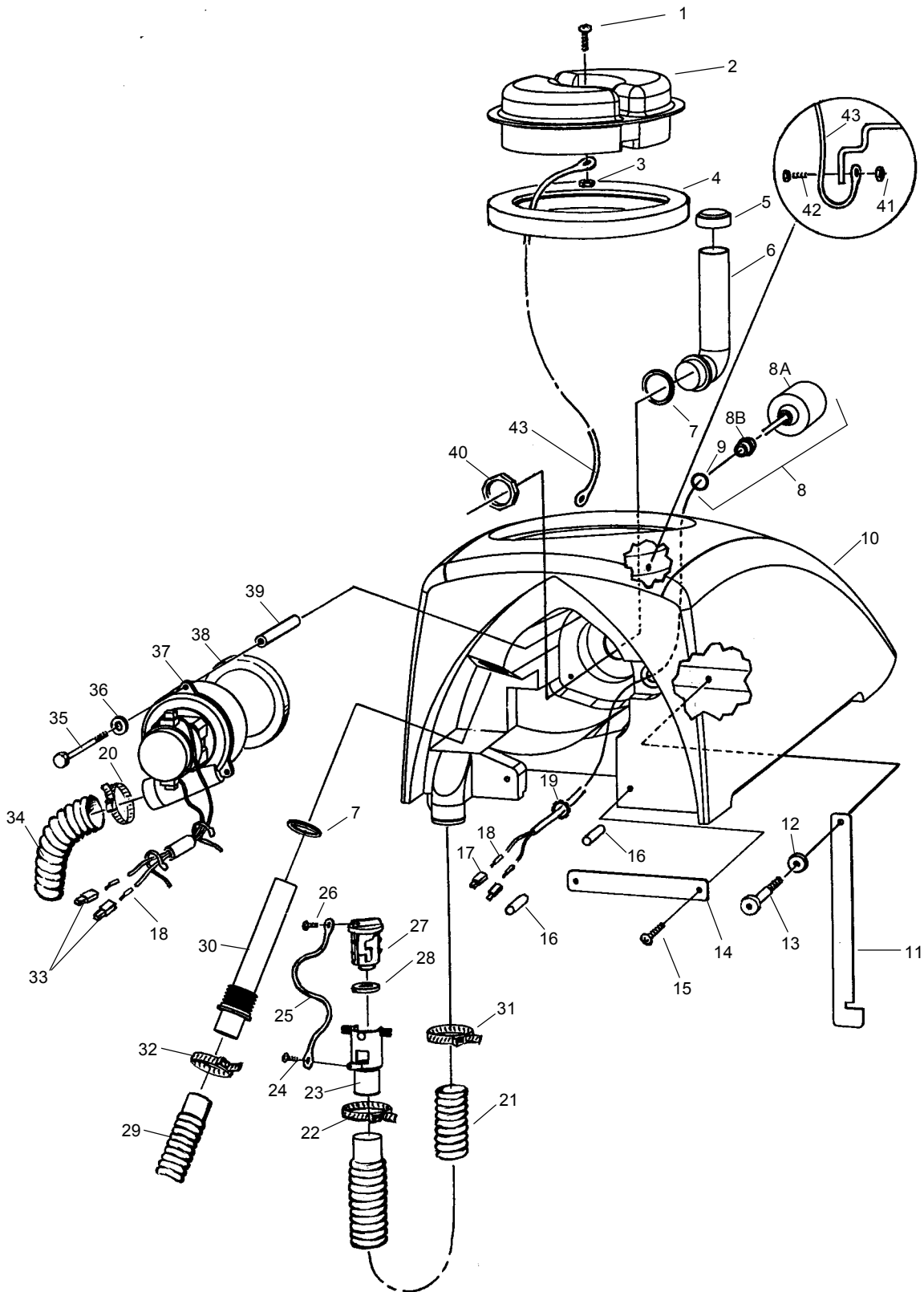

#40 Recommended Torque
 175 + or - 5 inch pounds

CLARKE TECHNOLOGY
Encore S2426/L2426
Recovery Tank Assembly Parts List 8/00

Ref. #	Part No.	Description	Qty
1	962798	Screw, 10-24 x .5	1
2	30057A	Lid	1
3	81110A	Nut, 10-24 SS	1
4	30065A	Gasket, Lid	1
5	58069A	Strainer	1
6	39338A	Stand Tube	1
7	837304	O-Ring	2
8	10660A	Switch Kit, (Includes 8A, 8B, 9)	1
8A	40002A	Switch (included in Item 8)	1
8B	56459A	Relief, Strain (included in Item 8A)	1
9	59877A	Seal, Washer	1
10	30061A	Tank, Recovery	1
11	60373A	Latch, Recovery Tank	1
12	87622A	Washer, Nylon 5/16 x 5/8 x 1/32	1
13	80043A	Screw, .25 x 20 x .25, Shoulder	1
14	60336A	Strap, Hose Retainer	1
15	85100A	Screw, 10-32 x 1/2 SS Xylan Coating	2
16	30068A	Hinge, Pin (included w/ item 10)	2
17	43402A	Housing, Connector(included in 8A)	2
18	41809A	Contact (included in 8A)	4
19	82100A	Nut, Strain Relief Lock	1
20	872010	Clamp, Hose	1
21	35165A	Hose, Drain	1
22	832002	Clamp, Hose	1
23	839401	Valve, Drain	1
24	962943	Screw, 8-18 x 1/2 PN	1
25	52206A	Chain	1
26	962987	Screw, 10-24 x 3/8 Pan	1
27	833901	Drain, Valve Handle	1
28	833407	Gasket, Drain Valve	1
29	51060A	Hose, Squeegee	1
30	830208	Squeegee Stand Tube	1
31	80110A	Hose Clamp	1
32	752020	Hose Clamp	1
33	43401A	Housing, Vac Motor Connector	2
34	674110	Hose	1
35	85728A	Screw, 1/4-20 x 4 Hex	3
36	87026A	Washer, 1/4 Flat	3
37	51049A	Motor, Vacuum (3-Stage)	1
	51050A	Motor, Vacuum, (2-Stage Option)	1
38	643418	Gasket	1
39	58533A	Spacer	3
40	920797	Nut	1
41	962666	Screw, 10-24 x 3/4	1
42	920296	Nut, 10-24 Elastic	1
43	38020A	Strap	1
NI	839410	Valve Asm. (includes 23, 24, 25, 26, 27, 28)	1
NI	70226A	Label, Battery Installation	1

CLARKE TECHNOLOGY Encore S2426/L2426
Solution Tank Assembly Drawing 5/01
Drawing #10063A

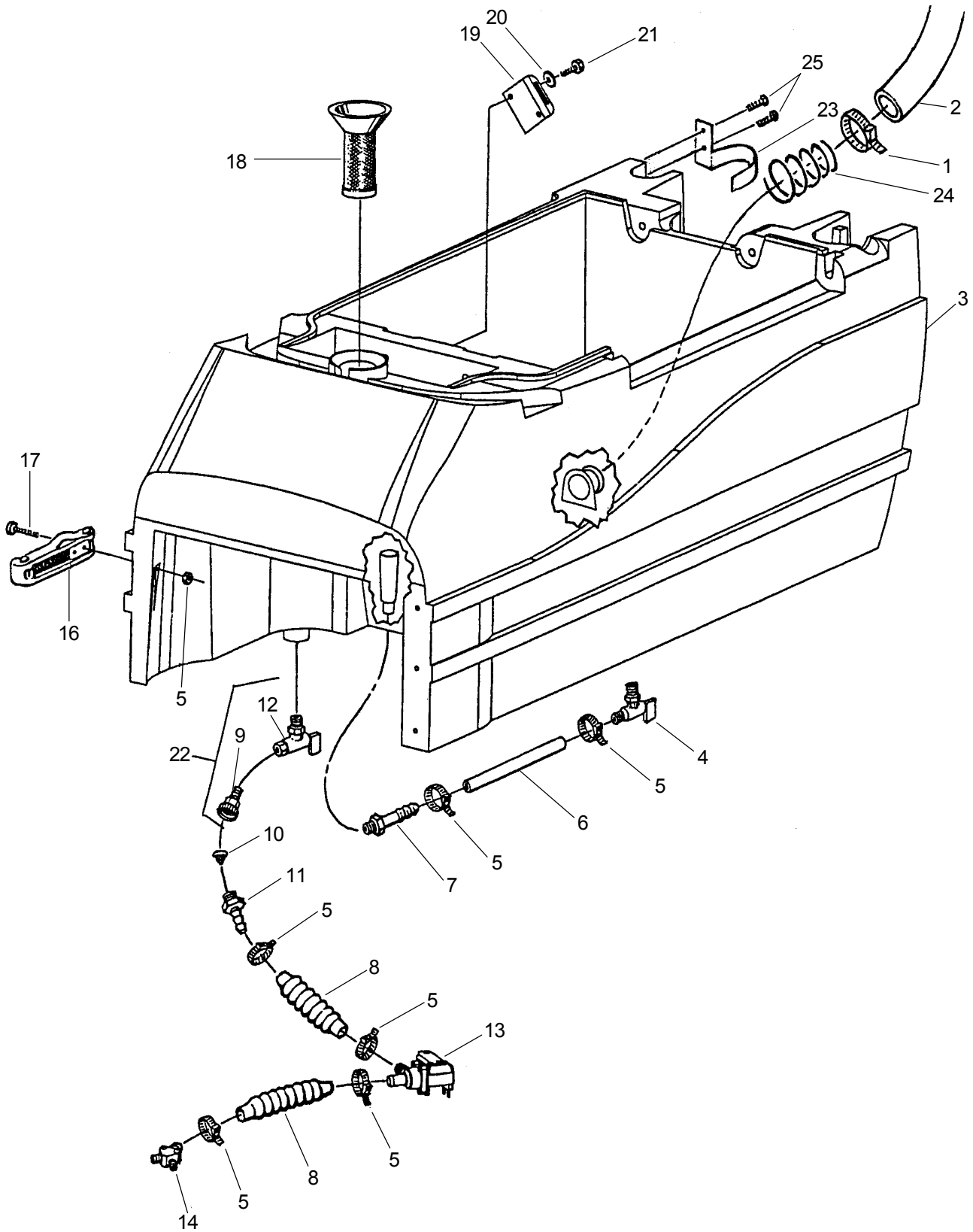

CLARKE TECHNOLOGY
Encore S2426/L2426
Solution Tank Assembly Parts List 5/01

Ref. #	Part No.	Description	Qty
1	872010	Clamp, Hose	1
2	50964A	Hose, Drain	1
3	30060A	Tank, Solution	1
4	59614A	Valve, Battery Drain	1
5	722030	Clamp, Hose	6
6	30453A	Hose, Clear Vinyl	1
7	820207	Adapter, Hose 3/8 MPT x 1/2 Hosebarb	1
8	30412A	Hose, Stretch	2
9	51205A	Adapter, Female	1
10	838517	Filter, Screen	1
11	830214	Adapter, Male, 3/4 Barb x GHT Male Thread	1
12	51204A	Valve, Solution	1
13	59789A	Valve, Solution	1
14	38014A	Splitter	1
15	81109A	Nut, 8-32 ESNA SS	2
16	50966A	Latch	1
17	80105A	Screw, 8-32 x 1 1/4 SS	2
18	50963A	Screen, Fill (with hose retention)	1
	51308A	Strainer (without hose retention)	1
19	69879A	Bracket, Latch	1
20	170892	Washer, Lock 1/4	2
21	170915	Screw, 1/4-20 x 3/4 SS Hex	2
22	51059A	Valve Assembly, Solution Shut-Off (incl. #9,12)	1
23	60480A	Bracket, Hose	1
24	51346A	Spring, Hose	1
25	80108A	Screw, 10-24 x 1/2	2
NI	30162A	Funnel (included w/Kit 10177A)	1
NI	10177A	Kit, Solution Fill (includes #18-51308A)(includes NI - 30162A)	1

CLARKE TECHNOLOGY
Encore S2426/L2426
Rear Panel Assembly Drawing 8/00
Drawing #10064A (L)
Drawing #10067A (S)

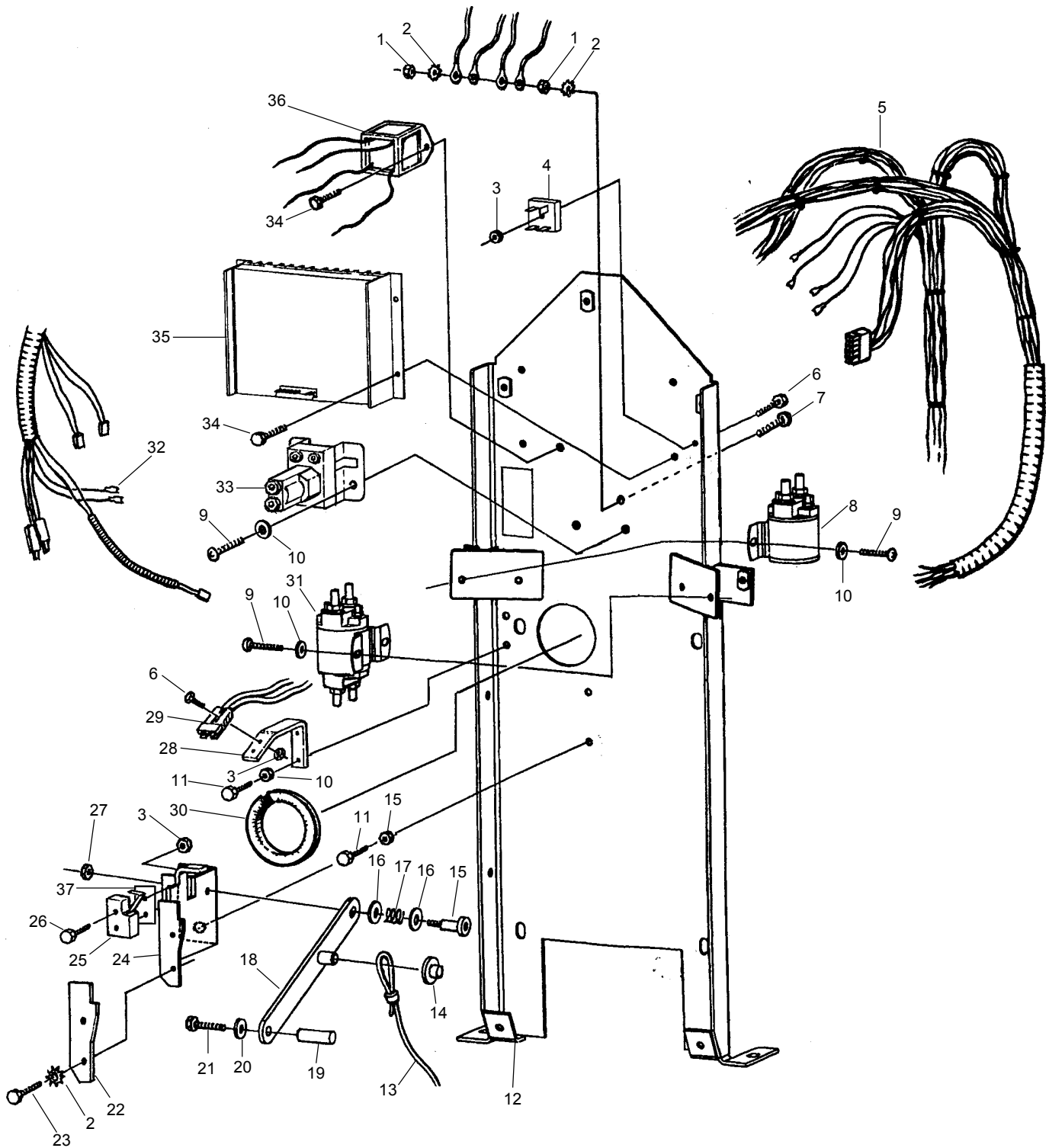

CLARKE TECHNOLOGY
Encore S2426/L2426
Rear Panel Assembly Parts List 5/01

Ref. #	Part No.	Description	Qty L	Qty S
1	920224	Nut, 10-32	2	-
2	980603	Washer, Starlock	4	2
3	920056	Nut, 6-32	5	4
4	46106A	Rectifier	1	-
5	40133A	Harness, Power "L"	1	-
	40134A	Harness, Power "S"	-	1
6	962212	Screw, 6-32 x 7/8	3	2
7	85383A	Screw, 10-32 x 3/4	1	-
8	41810A	Solenoid, Brush	1	1
9	85395A	Screw, 1/4-20 x 1/2	6	6
10	980614	Washer, Starlock, 1/4	10	10
11	85391A	Screw, 1/4-20 x 5/8	4	4
12	60261A	Panel, Rear Metal	1	1
13	60257A	Cable, Squeegee Lift	1	1
14	920346	Nut, Pal	1	1
15	80028A	Bolt, Shoulder, 5/16 x 1.0	1	1
16	980692	Washer, Flat 5/16 SS	2	2
17	438360	Spring	1	1
18	64901A	Lever, Squeegee Lift	1	1
19	64490A	Handle, Squeegee	1	1
20	980666	Washer, 3/8 Starlock	1	1
21	85389A	Screw, 3/8-16 x 5/8	1	1
22	68643A	Plate, Vacuum Wear	1	1
23	962968	Screw, 10-24 x 1/2	2	2
24	61260A	Plate, Squeegee Lift	1	1
25	47374A	Switch, Vacuum Lever	1	1
26	85601A	Screw, 6-32 x 1 1/4 PN	2	2
27	81217A	Nut, 1/4-20 x .218H Nylock	1	1
28	60264A	Bracket, Power Connector	1	1
29	41146A	Cable, Assembly Console	1	1
30	193951	Grommet, slotted, 8"	Ref	Ref
31	41811A	Solenoid, Main	1	-
	41810A	Solenoid, Main	-	1
32	40157A	Harness, Traverse	1	-
33	40169A	Solenoid, Vacuum	1	1
34	962798	Screw, 10-24 x 1/2	4	2
35	40132A	Control, Traverse	1	-
36	14097A	Low voltage Shutoff	-	1
37	30097A	Insulator, Mylar	1	1
NI	77093A	Label, Falling Parts	1	1
NI	77092A	Label, Gases	1	1
NI	47809A	3/8 Ring Terminal, 14-16	-	1
NI	911933	#10 Ring Terminal, 14-16	-	1
NI	40519A	Ring Terminal, 5/16	-	1

CLARKE TECHNOLOGY Encore S2426/L2426
Control Panel Assembly Drawing 8/00
Drawing #10065A "L" and 10066A "S"

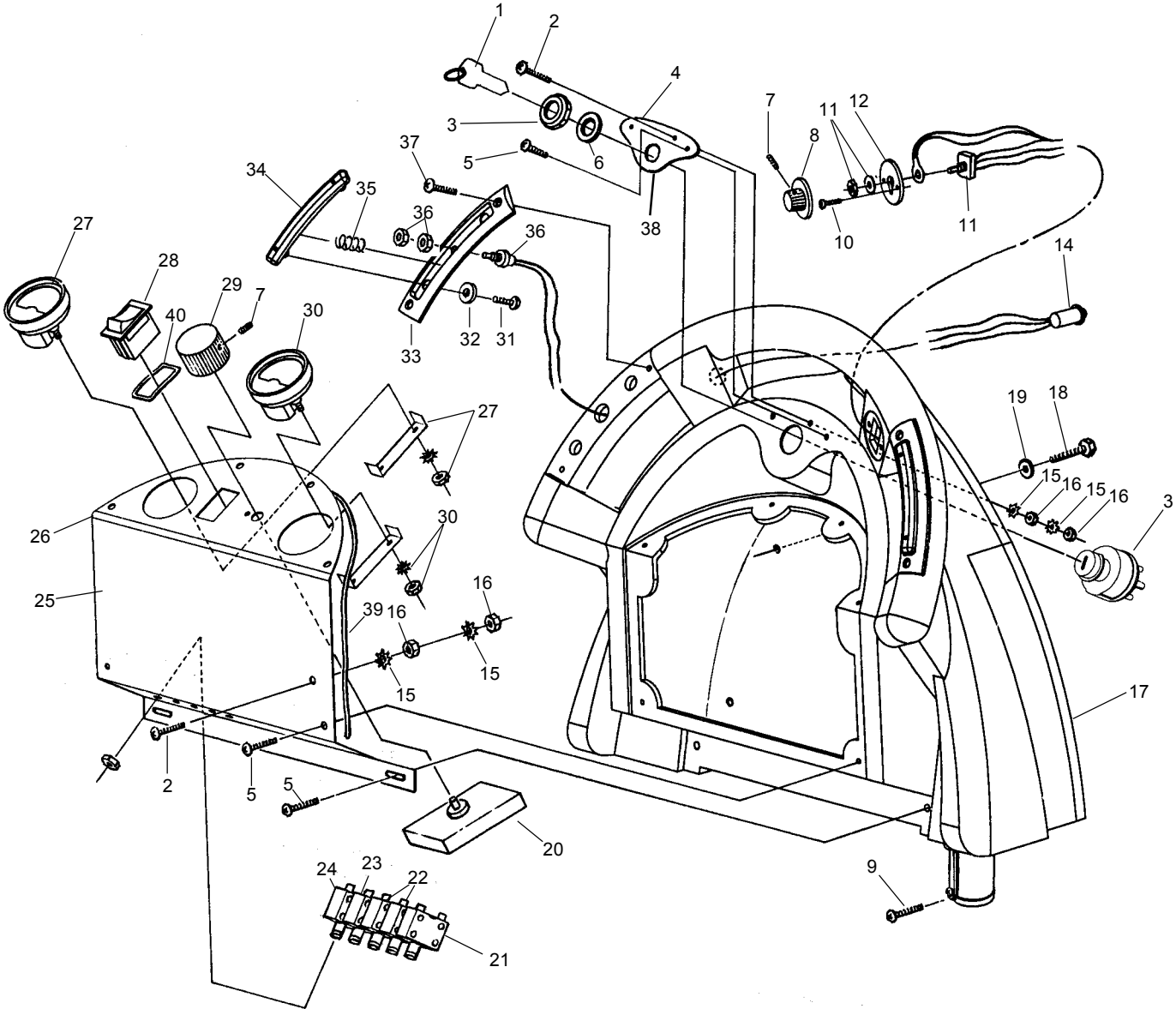

**CLARKE TECHNOLOGY Encore S2426/L2426
Control Panel Assembly Parts List 8/00**

Ref. #	Part No.	Description	Qty "L"	Qty "S"
1	55413A	Key (included w/Item 3)	Ref	Ref
2	84237A	Screw, 10-32 x 1/2	2	2
3	47380A	Switch, Key	1	1
4	60334A	Panel, Key Switch	1	1
5	80108A	Screw, 10-24 x 1/2 SS Black Xylan	8	8
6	87052A	Washer, Switch	1	1
7	962262	Screw, Set 8-32 x 1/2 (included in item 29)	4	2
8	50962A	Traverse, Control Knob	1	-
9	85703A	Screw, 10-00 x 1/2 PN	1	1
10	962957	Screw, 10-16	2	-
11	40135A	Harness, Potentiometer Assembly.	1	-
12	60259A	Bracket, Traverse Switch	1	-
13	980666	Washer, 3/8 Starlock	1	-
14	40158A	Switch, Reverse	1	-
15	980603	Washer	4	2
16	920224	Nut, 10-32 Hex	4	2
17	30062A	Control Handle	1	-
	30072A	Control Handle	-	1
18	85391A	Screw, 1/4-20 x 1/2 SS	Ref	Ref
19	87026A	Washer, 1/4 SS	Ref	Ref
20	44308B	Control, Solution	1	1
21	41422A	Breaker, Circuit 25 Amp Traverse	1	-
22	41433A	Breaker, Circuit 40 Amp Brush	2	2
23	41448A	Breaker, Circuit 30 Amp Vac	1	1
24	41423A	Breaker, Circuit 5 Amp Actuator	1	1
25	70186A	Label, Control "L"	1	-
	70187A	Label, control "S"	-	1
26	60258A	Panel, Control, Metal	1	1
27	40217B	Meter, Battery	1	1
28	40168A	Switch, Brush Adjustment	1	1
29	55502A	Knob	1	1
30	51057A	Meter, Brush	1	1
31	962330	Screw, 6-32 x 3/8	4	4
32	980608	Washer	4	4
33	30056A	Housing, Switch & Lever	2	2
34	30055A	Lever, Switch	2	2
35	50961A	Spring, Switch	4	4
36	40126A	Switch, Forward/Reverse	2	2
37	80104A	Screw, 10-32 x 1/2 SS Black Xylan	4	4
38	70219A	Label, Key Switch	1	1
39	34264A	Gasket, Panel	1	1
40	30096A	Gasket, Switch	1	1
NI	47708A	1/4 F.I.M.Q.D.	4	2
NI	47712A	1/4 F.I.F.Q.D.	1	0
NI	912226	Meter, Hour (Optional)		

CLARKE TECHNOLOGY Encore S2426/L2426
Squeegee Lift Assembly Drawing 6/00
Drawing # 10075A

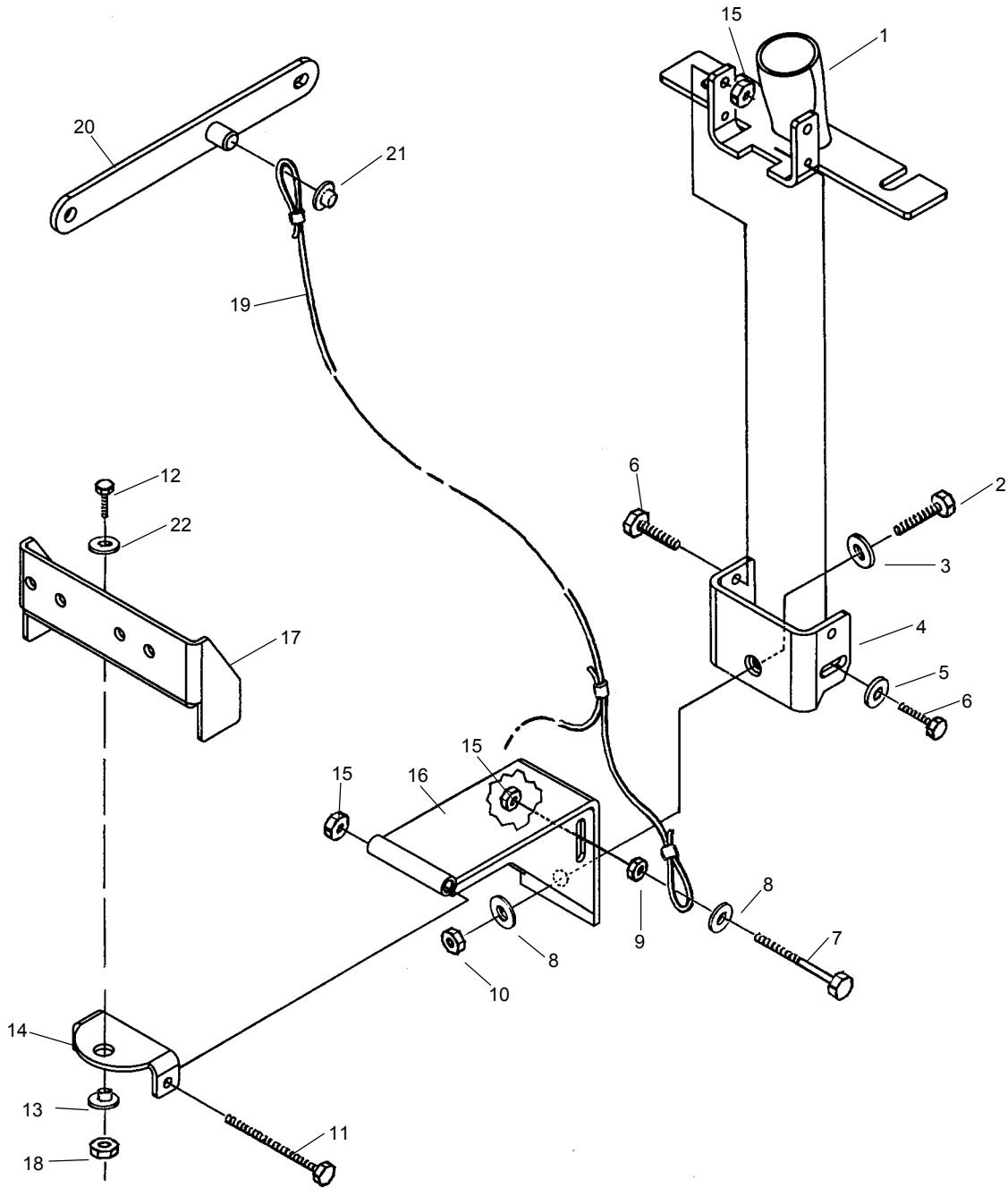

**CLARKE TECHNOLOGY Encore S2426/L2426
Squeegee Lift Assembly Parts List 6/00**

Ref. #	Part No.	Description	Qty
1	61263A	Bracket Tube	1
2	85730A	Screw, 3/8-16 x 1¼, Hex SS	1
3	980638	Lockwasher, 3/8 LT Spring Type	1
4	69860B	Bracket, Pin	1
5	87026A	Washer, ¼ SS	2
6	170915	Screw, ¼-20 x ¾	4
7	962481	Screw, ¼-20 x 1¼ Hex	2
8	87031A	Washer, 3/8 Flat	3
9	920208	Nut, ¼-20	2
10	81111A	Nut, 3/8-16 ESNA	1
11	80101A	Screw, ¼-20 x 3¼ SS	1
12	85811A	Screw, 5/16-18 x ¾	1
13	67867A	Nut, spacer	1
14	60256A	Squeegee, Pivot Arm	1
15	81104A	Nut, ¼ Nylock	5
16	60255A	Bracket, Squeegee	1
17	60328A	Mount, Squeegee	1
18	81112A	Nut, 5/16-18 Thin ESNA SS	1
19	Page 37	Cable, Squeegee Lift	Ref
20	Page 37	Lift Handle Assembly	Ref
21	920346	Palnut	Ref
22	980651	Washer	1

CLARKE TECHNOLOGY Encore S2426/L2426
Squeegee Assembly Drawing 10/00
Drawing # 10068A and 10129A

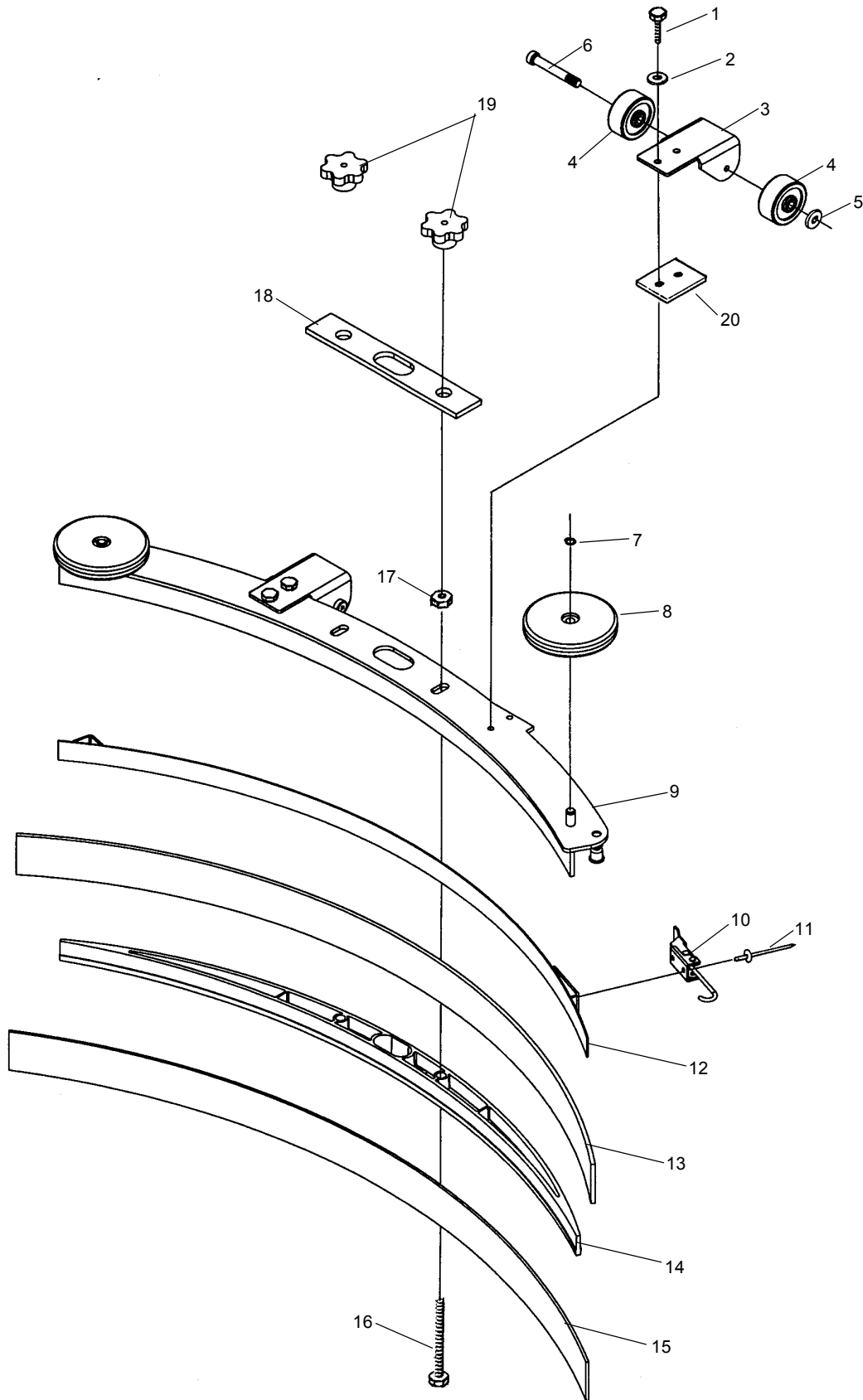

**CLARKE TECHNOLOGY Encore S2426/L2426
Squeegee Assembly Parts List 10/00**

Ref. #	Part No.	Description	10068A	10129A
			39" Qty	32" Qty
1	962720	Screw, 1/4-20 x 1/2 Hex SS	4	4
2	980657	Washer, 1/4 Lock	4	4
3	60243A	Bracket, Squeegee Wheel	2	2
4	30049B	Wheel, Squeegee	4	4
5	81104A	Nut, 1/4-20	2	2
6	60254A	Bolt, Shoulder 5/16x 2 1/4	2	2
7	50958A	Ring, 3/8 ID Snap	2	2
8	30048A	Wheel, Guide, 4 Inch Diameter	2	2
9	60272A	Channel, Squeegee Weldment 39"	1	-
	60234A	Channel, Squeegee Weldment 32"	-	1
10	50835A	Latch, Squeegee Clamp	1	1
11	930086	Rivet, 3/16 x .450 Aluminum	2	2
12	60252A	Strap, Clamp, Squeegee Retainer 39"	1	-
	60232A	Strap, Clamp, Squeegee Retainer 32"	-	1
13	30069A	Blade, Rear, Gum Rubber, 39"	1	-
	30067A	Blade, Rear, Gum Rubber, 32"	-	1
14	30058A	Spacer, Squeegee 39"	1	-
	30047A	Spacer, Squeegee 32"	-	1
15	30091A	Blade, Front Ribbed 39"	1	-
	30066A	Blade, Front Ribbed 32"	-	1
16	80011A	Screw, 3/8-16 x 3	2	2
17	81301A	Nut, 3/8-16 Jam SS	2	2
18	34260B	Gasket	1	1
19	25201A	Knob	2	2
20	60358A	Shim, Squeegee Wheel	2	2

CLARKE TECHNOLOGY Encore S2426/L2426
Frame Axle Assembly Drawing 11/23/00
Drawing #10069A and 10070A

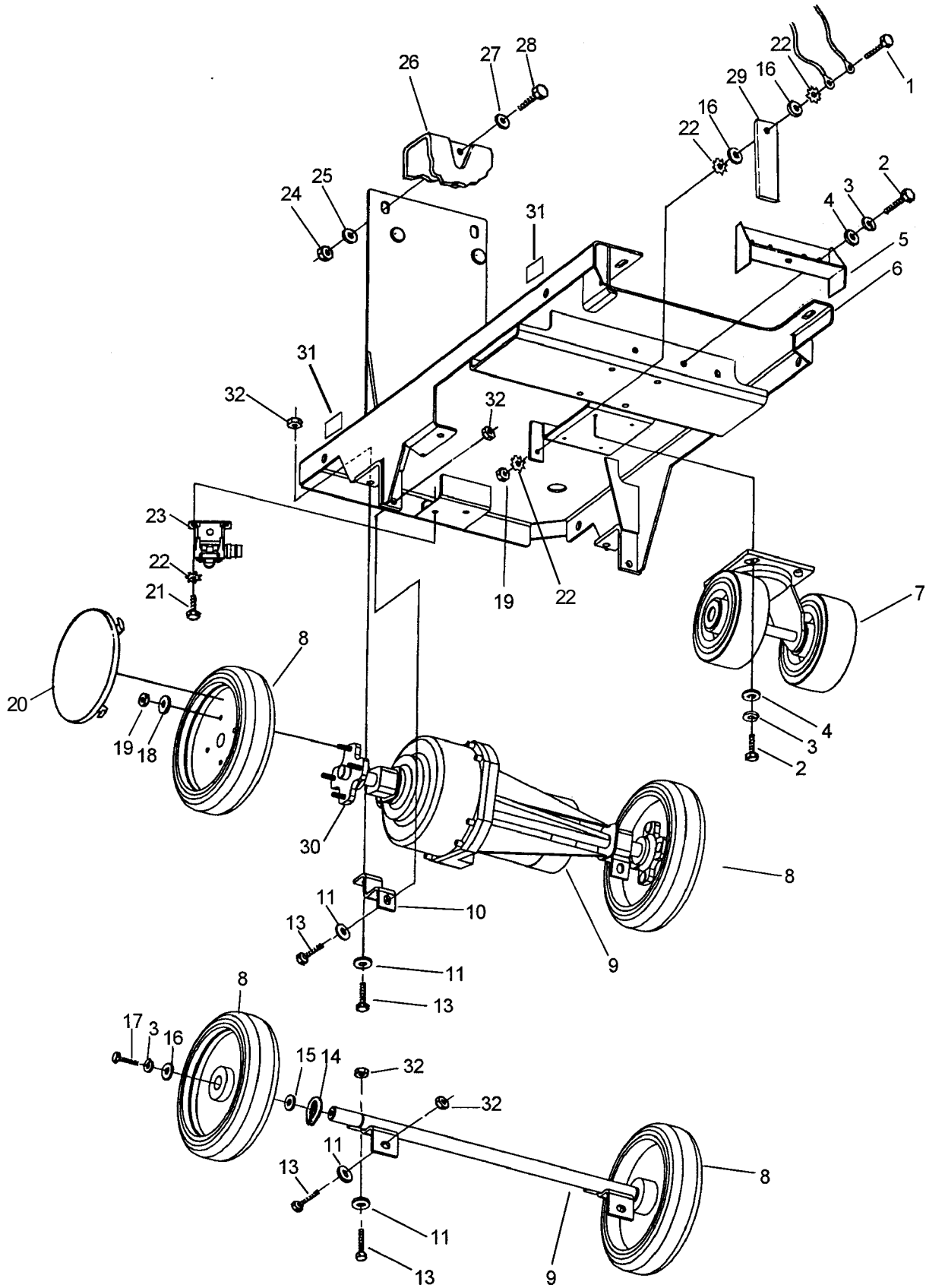

CLARKE TECHNOLOGY
Encore S2426/L2426
Frame Axle Assembly Parts List 11/23/00

Ref. #	Part No.	Description		
			Traverse	Non-Traverse
			Qty	Qty
1	85700A	Screw, 1/4-20 x 1	1	-
2	85811A	Screw, 5/16-18 x 3/4	6	6
3	980652	Washer, 5/16 Lock	6	8
4	980651	Washer, flat 5/16	6	6
5	60328A	Squeegee Mount	Ref	Ref
6	60260B	Frame Assembly	1	1
7	50968A	Caster, Assembly	1	1
8	30071A	Wheel Assembly	2	-
	69205A	Wheel, Non Traverse	-	2
9	50967A	Transaxle w/mounting hubs	1	-
	60266A	Non-Traverse Axle Assembly	-	1
10	60289A	Mount, Transaxle	2	-
11	87031A	Washer, flat 3/8 SS	4	4
12	170883	Washer, 3/8 Lock	4	4
13	80103A	Screw, 3/8-24 x 1 Hex SS	4	4
14	57423A	Ring, Snap Retainer	-	2
15	87616A	Washer, Nylon	-	2
16	980205	Washer, 5/16 Fender	2	2
17	962620	Screw, 5/16-24 x 3/4	-	2
18	87026A	Washer, Flat, 1/4 SS	8	-
19	81217A	Nut, 1/4-20 SS Thin	9	-
20	34711B	Wheel Cover	2	2
21	85395A	Screw, 1/4-20 x 1/2 SS	2	2
22	980614	Washer, 1/4 Starlock	5	2
23	59789A	Valve Solution	Ref	Ref
24	81105A	Nut, 3/8-16 ESNA	Ref	Ref
25	87031A	Washer, Flat 3/8 SS	Ref	Ref
26	Ref	Solution Tank	Ref	Ref
27	980205	Washer, 5/16	Ref	Ref
28	85734A	Screw, 3/8-16 x 2	Ref	Ref
29	69639A	Strap, Static	1	-
30	10135A	Hub, Transaxle (includes #9)		
31	77267A	Label, Tie Down	4	4
32	81108A	Nut, 3/8-24 ESNA	4	4

CLARKE TECHNOLOGY
Encore S2426/L2426
Brush Head Assembly Drawing 8/00
Drawing #10071A and 10061A

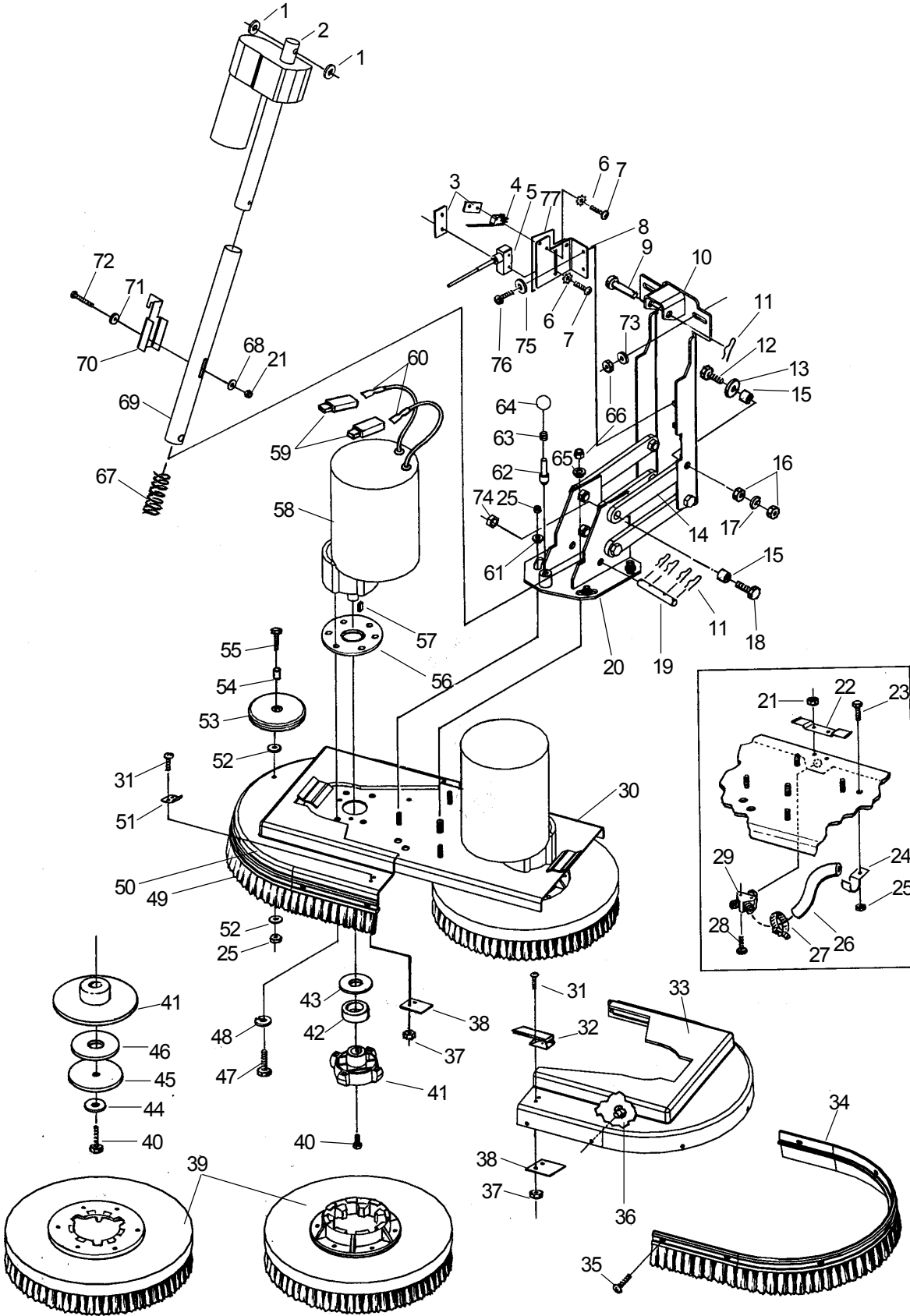

CLARKE TECHNOLOGY
Encore S2426/L2426
Brush Head Assembly Parts List 8/00
Drawing #10071A and #10061A

Ref. #	Part No.	Description	Qty	
			L	S
1	38708A	Washer, Spacer Nylon	2	2
2	50950A	Actuator	1	1
3	60265A	Plate, Nut	2	2
4	47374A	Switch, Lever	1	1
5	47422B	Switch, Whisker	1	1
6	980608	Washer, #6	4	4
7	962980	Screw, 6-32 x 1	4	4
8	60251A	Mount, Switch	1	1
9	82501A	Pin	1	1
10	60236A	Bracket, Brush Head	1	1
11	766780	Pin, Hair	5	5
12	85838A	Screw, 1/2 x 20 x 1 1/2	4	4
13	980673	Washer	4*	4*
14	63058A	Bar, Linkage	4	4
15	67705B	Bearing, Sleeve	8	8
16	920278	Nut, 1/2-20 SS	8	8
17	980626	Washer, 1/2 Lock	4	4
18	80100A	Screw, 1/2-20 x 1 Hex Head	4	4
19	80091A	Pin, Brush Lift	1	1
20	60239A	Mount, Brush Head	1	1
21	81217A	Nut, 1/4-20 ESNA .218 Height	3	3
22	60335A	Bracket, Brush Housing	1	1
23	170915	Screw, 1/4-20 x 3/4 SS	2	2
24	782002	Clamp, Hose	2	2
25	81104A	Nut, 1/4-20 ESNA	7	7
26	34705A	Hose, Solution	2	2
27	722030	Clamp, Hose	2	2
28	962989	Screw, 1/4-20 x 1 1/2	2	2
29	38014A	Solution Splitter	Ref	Ref
30	60235A	Plate, Brush Head	1	1
31	962992	Screw, 8-32 x 5/8 SS	4	4
32	55721A	Latch, Brush Housing	1	1
33	30053A	Housing, Left Brush	1	1
34	30051A	Skirt, Left	1	1
35	85616A	Screw, 10-32 x 5/8 SS	12	12
36	82004A	Nut, "T" 10-32	12	12
37	81109A	Nut, 8-32 SS ESNA	4	4
38	60337A	Plate, Latch Brush	2	2
39	Page 24	Brush/Pad Assemblies		

Ref.#	Part No.	Description	Qty	
			L	S
40	962714	Screw, 5/16-18 x 3/4 Soc.	2	-
	85811A	Screw, 5/16-18 x 3/4 Hex	-	2
41	34400B	Gimbal Male	2	-
	20308A	Motor, Adapter	-	2
42	61658A	Gimbal, Collar	2	-
43	59856A	Washer, Rubber	2	-
44	980652	Washer, 5/16 Lock	-	2
45	980210	Washer, Impeller	-	2
46	980679	Washer, Spacer	-	2
47	962244	Screw, 3/8-16 x 3/4	8	8
48	980638	Washer, Lock 3/8	8	8
49	30052A	Skirt, Right	1	1
50	30054A	Housing, Right Brush	1	1
51	55451A	Keeper	1	1
52	87039A	Washer, 1/4	2	2
53	30048A	Wheel, Guide	1	1
54	60248A	Sleeve Guide Wheel	1	1
55	85301A	Screw, 1/4-20 x 1 1/4	1	1
56	20014A	Spacer, Brush Tilt	-	2
57	915102	Key (included w/Item 58)	2	2
58	44809B	Motor, Brush	2	2
59	41602A	Housing	4	4
60	41601A	Connector	4	4
61	60240A	Bushing, Swivel Adj., 1/4	4	4
62	50839A	Pin, Plunger	1	1
63	50956A	Spring, Plunger	1	1
64	50957A	Knob	1	1
65	60241A	Bushing, Swivel, 3/8	1	1
66	81105A	Nut, 3/8-16 SS ESNA	1	1
67	53422A	Spring, Head Pressure	1	1
68	87007A	Washer, Flat, 1/4"	1	1
69	60238A	Tube, Head Pressure	1	1
70	60249A	Switch, Actuator	1	1
71	80102A	Washer, 1/4	1	1
72	85702A	Screw, 1/4-20 x 1 3/4	1	1
73	87031A	Washer, 3/8 Flat	Ref	Ref
74	80109A	Nut, 1/2-20 Jam S.S.	4	4
75	980603	Washer, #10	2	2
76	80108A	Screw, 10-24 x 1/2	2	2
77	30092A	Insulator, Mylar	1	1
NI	77091A	Label, Moving Parts	2	2

* Used only as required to square up linkage bar #14 to the frame.

CLARKE TECHNOLOGY
Encore S2426/L2426
Optional Brake Drawing and Parts List 11/23/00
10073A - "S" Model

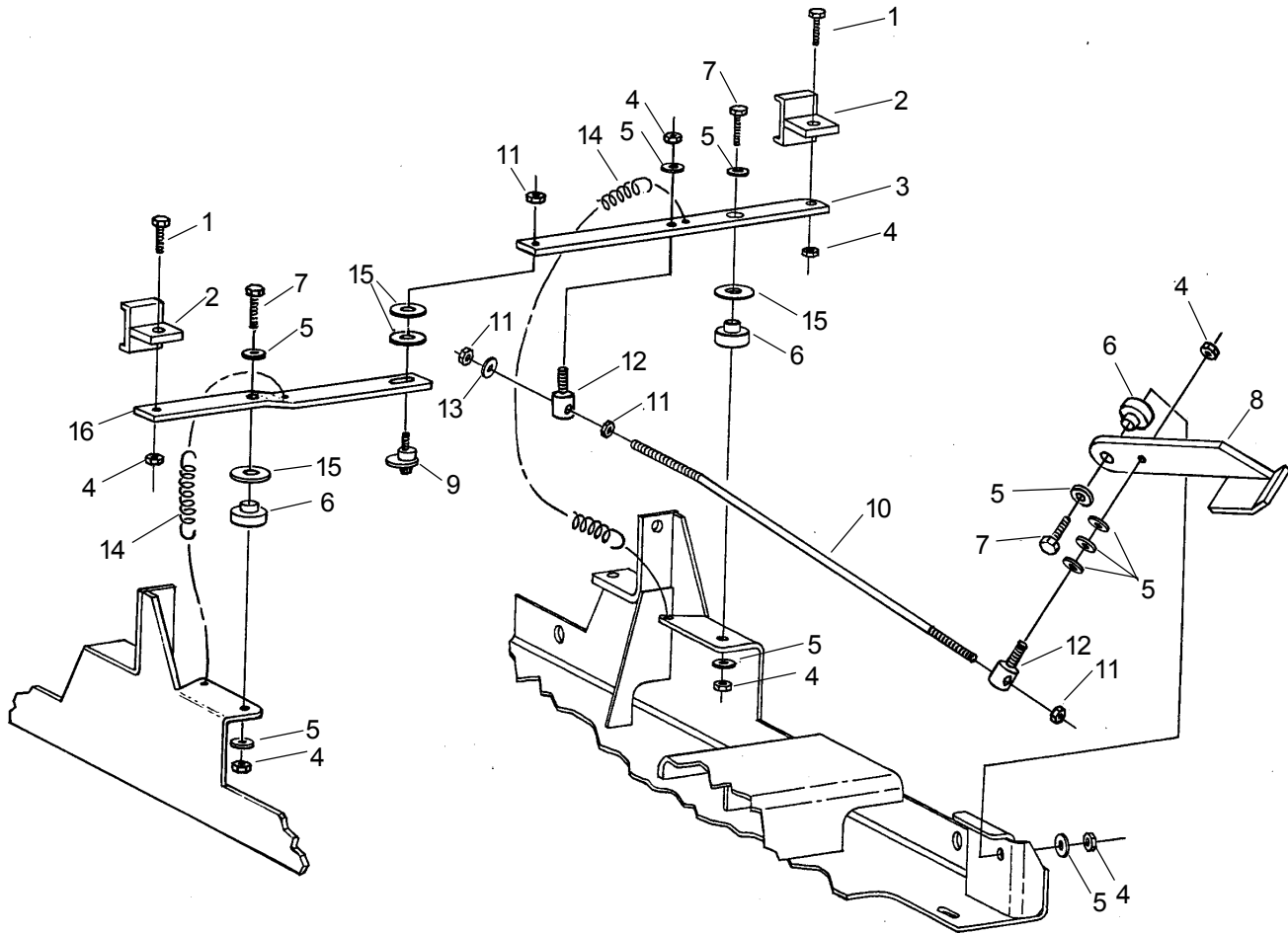

Ref. #	Part No.	Description	Qty
1	85811A	Screw, 5/16-18 x 3/4	2
2	60359A	Pad, Brake	2
3	60271A	Brake, Bar L.H.	1
4	920110	Nut, 5/16-18 ESNA	6
5	980651	Washer, Flat, 5/16	10
6	67877A	Spacer	3
7	85814A	Screw, 5/16-18 x 1 1/4	3
8	60268A	Lever, Brake Pedal	1
9	60361A	Cam, Brake	1
10	60267A	Rod, Brake	1
11	81104A	Nut, 1/4-20 ESNA	4
12	848508	Swivel, Rod, Brake	2
13	87026A	Washer, Flat, 1/4	1
14	50969A	Spring, Brake Asm.	2
15	87607A	Washer, Flat Nylon	4
16	60362A	Brake, Bar R.H.	1
NI	77266B	Label, Parking Brake	1

CLARKETECHNOLOGY
Encore S2426/L2426
Optional Brake Drawing and Parts List 5/01
10072A - "L" Model

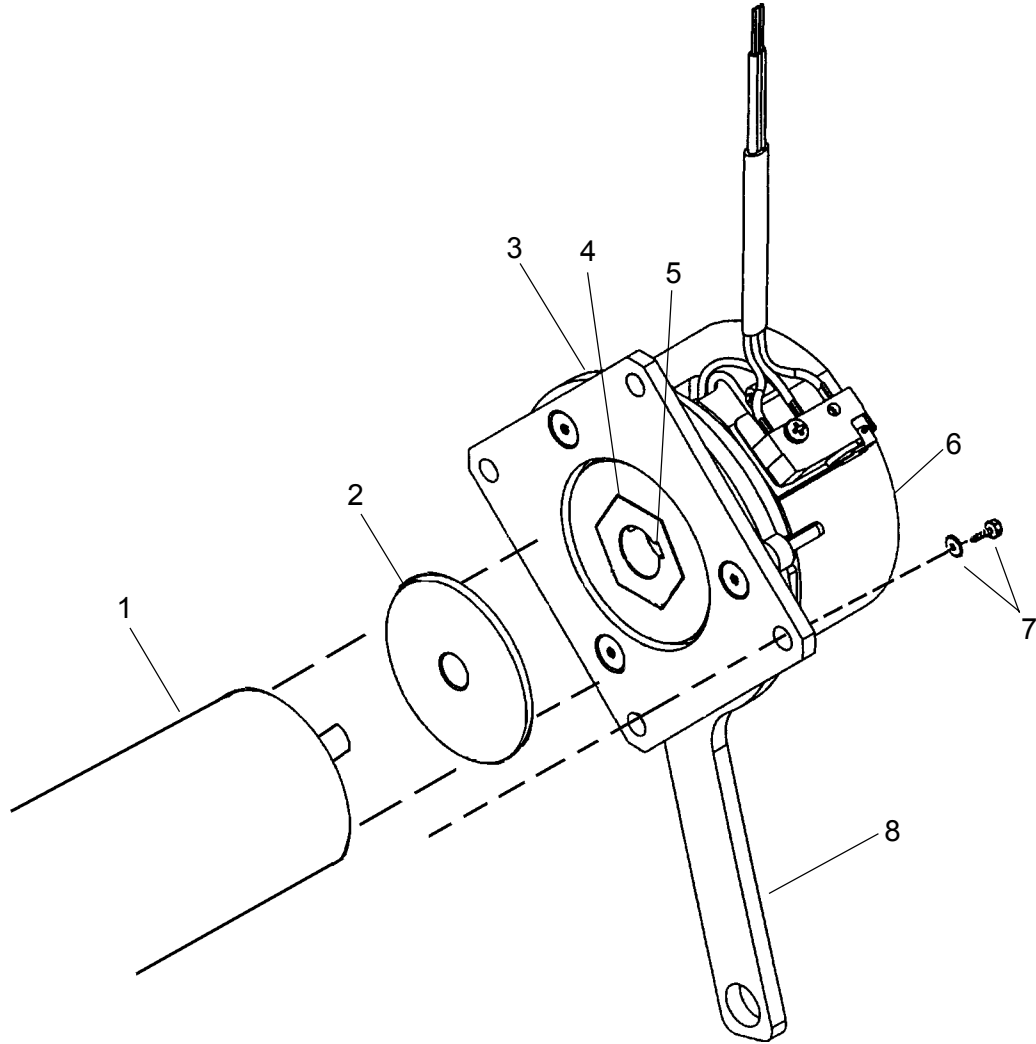

Ref #	Part No.	Description	Qty
1	50981A		
2	60388A	Spacer	1
3	30095A	Tie, Cover Retainer	1
4	80123A	Nut, Brake Drive	1
5	80125A	Key, 3/32 Sq. x 1/4 Lg.	1
6	30094A	Cover, Vinyl	1
7	80124A	Screw Set (Brake Nut to Motor Shaft)	2
8	10160A	Brake, Asm. 24V	1

NOTE: Only use spacer (ref. #2) on transaxles that have a circular step and mounting nuts protruding from end of motor. The motor that uses the spacer can be identified by the motor brush caps protruding past the outside diameter of the motor.

CLARKE TECHNOLOGY
Encore S2426/L2426
Vacuum Motor Drawing and Parts List
Drawing 5/00

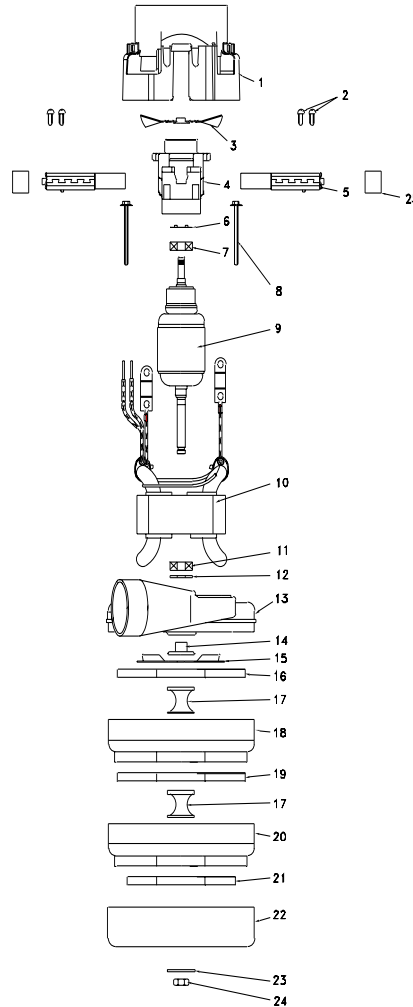

PARTS LIST			
DESCRIPTION	REQUIRED	ALTO S1049A	ALTO S1050A
1. HOUSING	1	50994A	50994A
2. SCREW	4	*	*
3. FAN	1	50995A	50995A
4. COMM END BRACKET	1	*	*
5. BRUSH MECHANISM	2	50996A	50996A
6. LOAD SPRING	1	*	*
7. BALL BEARING	1	*	*
8. SCREW	2	*	*
9. ARMATURE	1	*	*
10. FIELD	1	*	*
11. BALL BEARING	1	*	*
12. NEOPRENE WASHER	1	59803A	59803A
13. FAN END BRACKET	1	*	*
14. SPACER	1	*	*
15. FAN	1	50997A	50997A
16. ROTATING FAN	1	53914A	53914A
17. SPACER	2	50999A	50999A
18. STATIONARY FAN	1	51403A	51403A
19. ROTATING FAN	1	51404A	51404A
20. STATIONARY FAN	1	51405A	NA
21. ROTATING FAN	1	50998A	NA
22. FAN SHELL	1	51046A	51407A
23. WASHER	1	*	*
24. NUT	1	*	*
25. INSULATOR BRUSH CAP	2	51048A	51048A

1. THIS INFORMATION IS FOR PART IDENTITY ONLY, IT IS NOT TO BE USED AS DISASSEMBLY OR ASSEMBLY INSTRUCTIONS.
2. REPLACEMENT OF ARMATURE OR FIELD REQUIRES THE REPLACEMENT OF BRUSH MECHANISMS.

CLARKETECHNOLOGY
Encore S2426/L2426
Gearbox Assembly Drawing and Parts List 5/00
Form#54238A

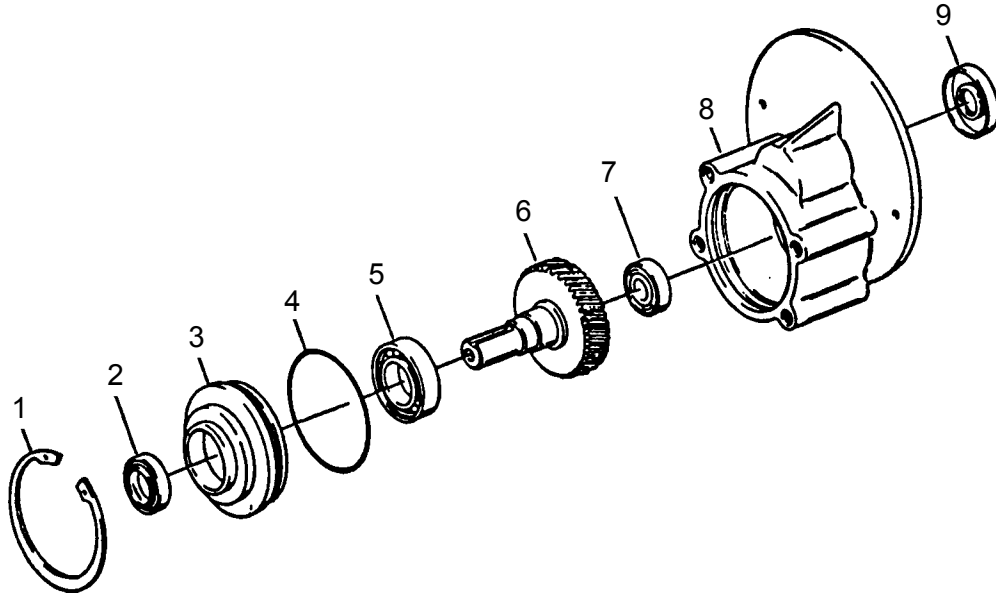

Ref #	Part No.	Description	Qty
1	57846A	Ring, Snap	1
2	507641	Seal, Oil, Small	1
3	52050A	Cap End	1
4	56668A	O-Ring	1
5	51176a	Bearing, Large	1
6	58316A	Shaft & Gear	1
7	902605	Bearing, Small	1
8	54883A	Housing	1
9	58144A	Seal, Oil Large	1
10	NI	Darina EP2 Grease	4 oz.

CLARKE TECHNOLOGY
Encore S2426/L2426
Brush Motor Drawing & Parts List 8/00
Motor Asm. 44809B

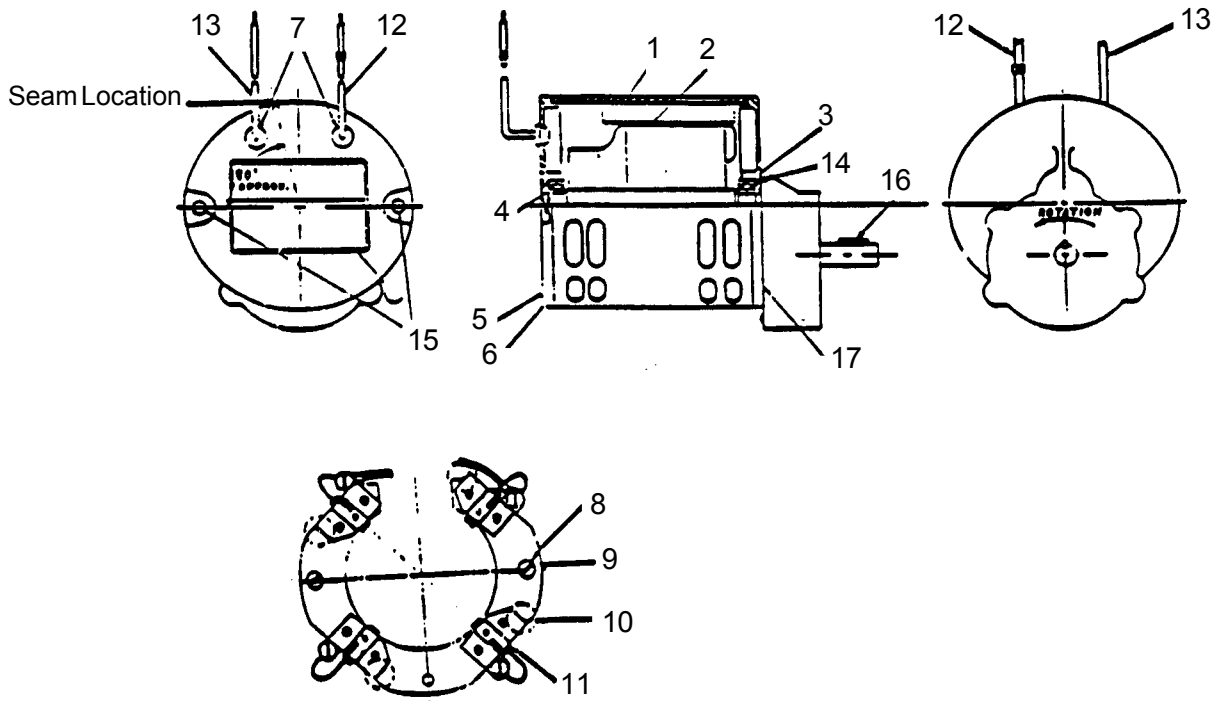

Item	Part No.	Description	Qty
1	56478A	Stator Frame Assembly (w/Magnets & Clips)	1
2	50142A	Armature Assembly (w. B.E. & F.E. Bearings)	1
3	902654	Bearings B.E.	1
4	902550	Bearing F.E.	1
* 5		Commutator Bracket Assembly (w/Brush BRD Assembly Leads)	1
6	50520A	Commutator Bracket	1
7	56480A	Strain Relief	2
8	962546	Brush Board Screw	2
9	50517A	Brush Board Assembly (w/ Springs & Brushes)	1
10	448396	Brush Spring	4
11	40826A	Brush Assembly	4
12	55657A	Lead Assembly	1
13	55656A	Lead Assembly	1
* 14		Helical Washer	1
15	50515A	Thru Bolt	2
16	80501A	Shaft Key	1
17	54238A	B.E. Bracket Assembly (Gear Box)	1

* NOTE: Parts not available at this time.

CLARKE TECHNOLOGY
Encore S2426/L2426
Transaxle Drawing 5/00

1	10135A	FLANGE WHEEL KIT	2
2	51056A	SLEEVE ELASTOMERIC	2
3	50983A	COUPLING MOTOR DRIVE	1
4	50982A	TRANSAXLE, W/O MOTOR	1
5	50981A	MOTOR	1
REF. NO.	PART NO.	DESCRIPTION	QTY.
PARTS LIST			

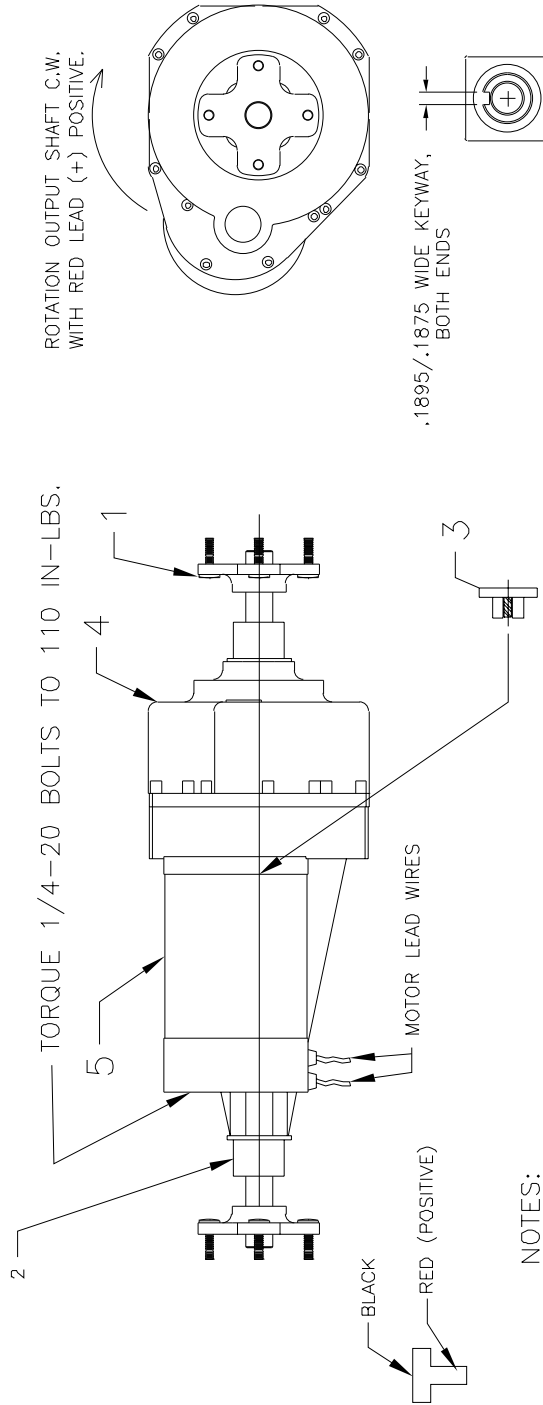

NOTES:

1. BALL AND NEEDLE BEARING CONSTRUCTION.
2. GEARBOX GREASE LUBRICATED AND LEAKPROOF.
3. AXLES TO BE RUST PROTECTED WITH PLATING
4. GEAR RATIO: 18:1
5. TRANSAXLE ASSEMBLY SUPPLIED WITH RUBBER MOUNT BUSHINGS INSTALLED.
6. MOTOR ASSEMBLY IS FIELD REPLACEABLE.
7. MOTOR FRAME ZINC PLATED.
8. WHEEL FLANGES & STUDS TO BE ZINC PLATED.
9. ELECTRICAL CONNECTORS - USE PACKARD HOUSING # 2984883 AND PACKARD TERMINAL # 2971859

CLARKE TECHNOLOGY
Encore S2426/L2426
Battery Charger Drawing and Parts List 5/00

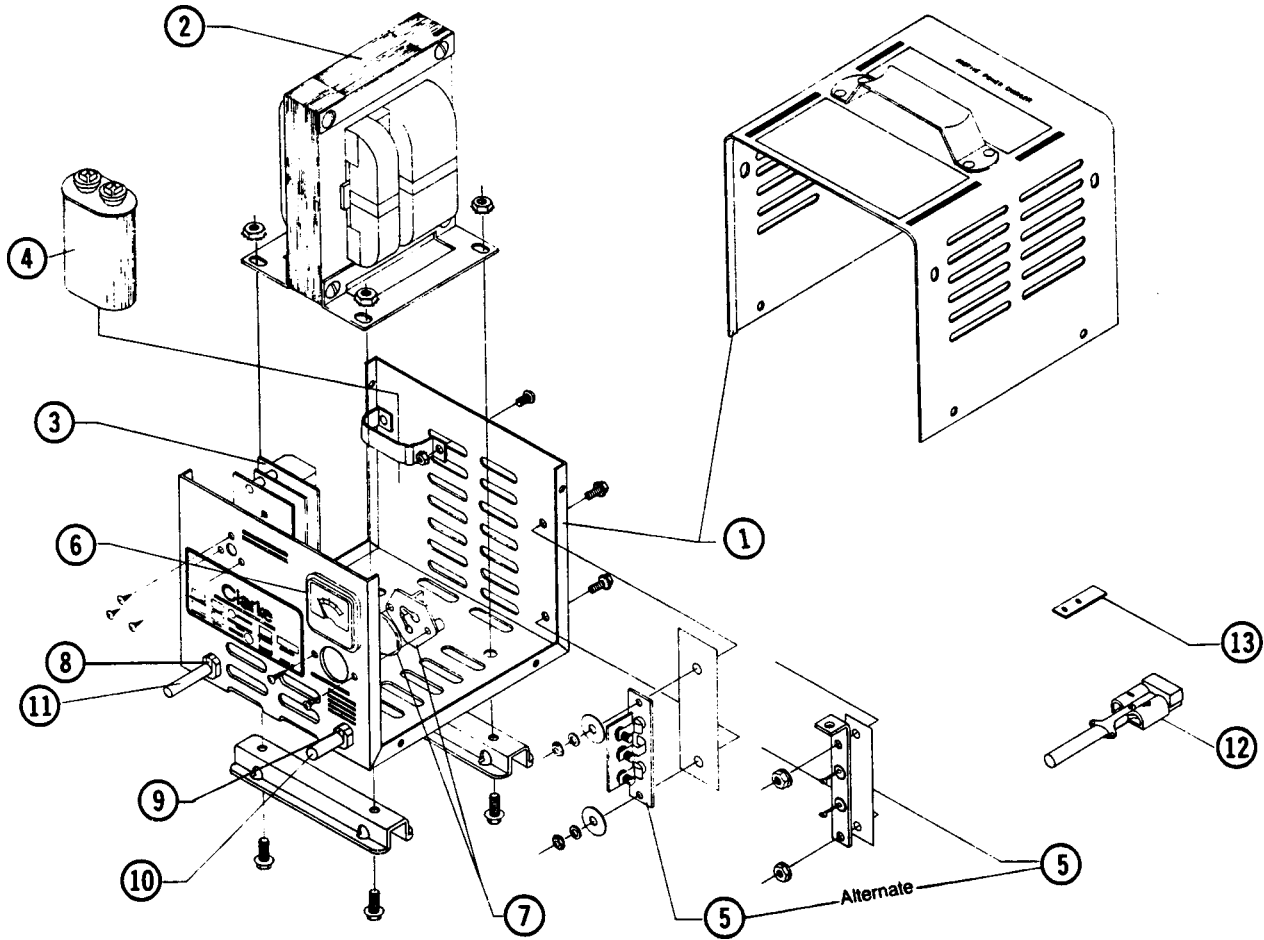

WARNING: All electrical repairs must be performed by qualified personnel only.

Charger #40512A: 24 volt, 25 amp D.C., 115 volt, A.C., 60 Hz.
Charger #40513A: 24 volt, 25 amp D.C., 230 volt, A.C., 50 Hz

Ref. No.	Description	Charger 40512A	Charger 40513A
1	Charger Case	41129A	41128A
2	Transformer	48413A	48409A
3	Electronic Controller Kit	47500A	48200A
4	Capacitor, 660 V.A.C.	912132	912132
5	Heat Sink Assembly	912212	912212
6	Ammeter	40200A	40200A
7	Fuse Holder	912382	912382
8	Strain Relief, A.C. Cord	837525	837525
9	Strain Relief, D.C. Cord	747553	747553
10	D.C. Cord Assembly	51986A	51986A
11	A.C. Cord Assembly	51974A	908947
12	Housing, Red	911470	911470
13	D.C. Plug Lock Key	795020	795020

* NOTE: Parts not available at this time.

CLARKE TECHNOLOGY

Encore S2426

Connection Diagram (00932A-W) 6/00

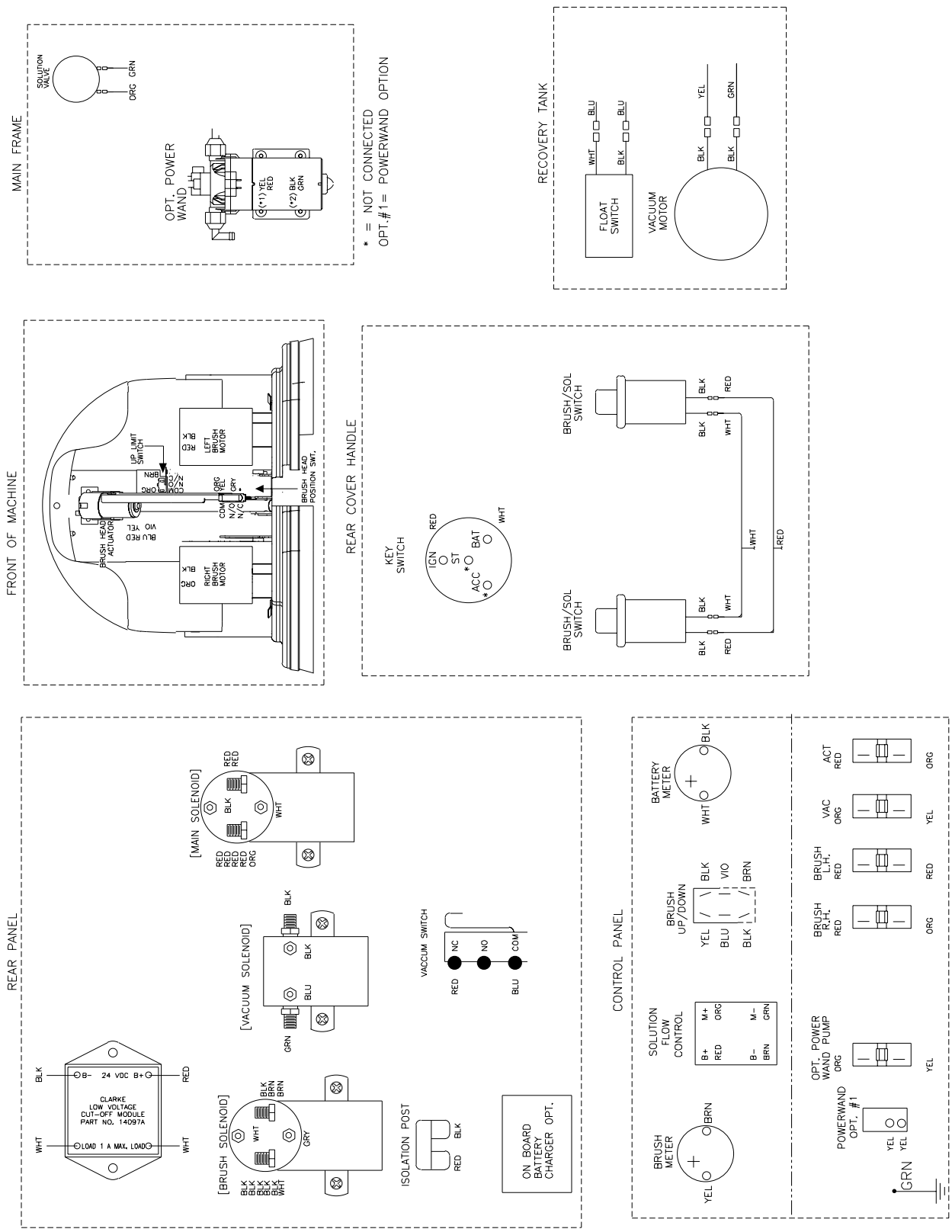

CLARKE TECHNOLOGY
Encore S2426
Electrical Schematic (00932A-E) 5/00

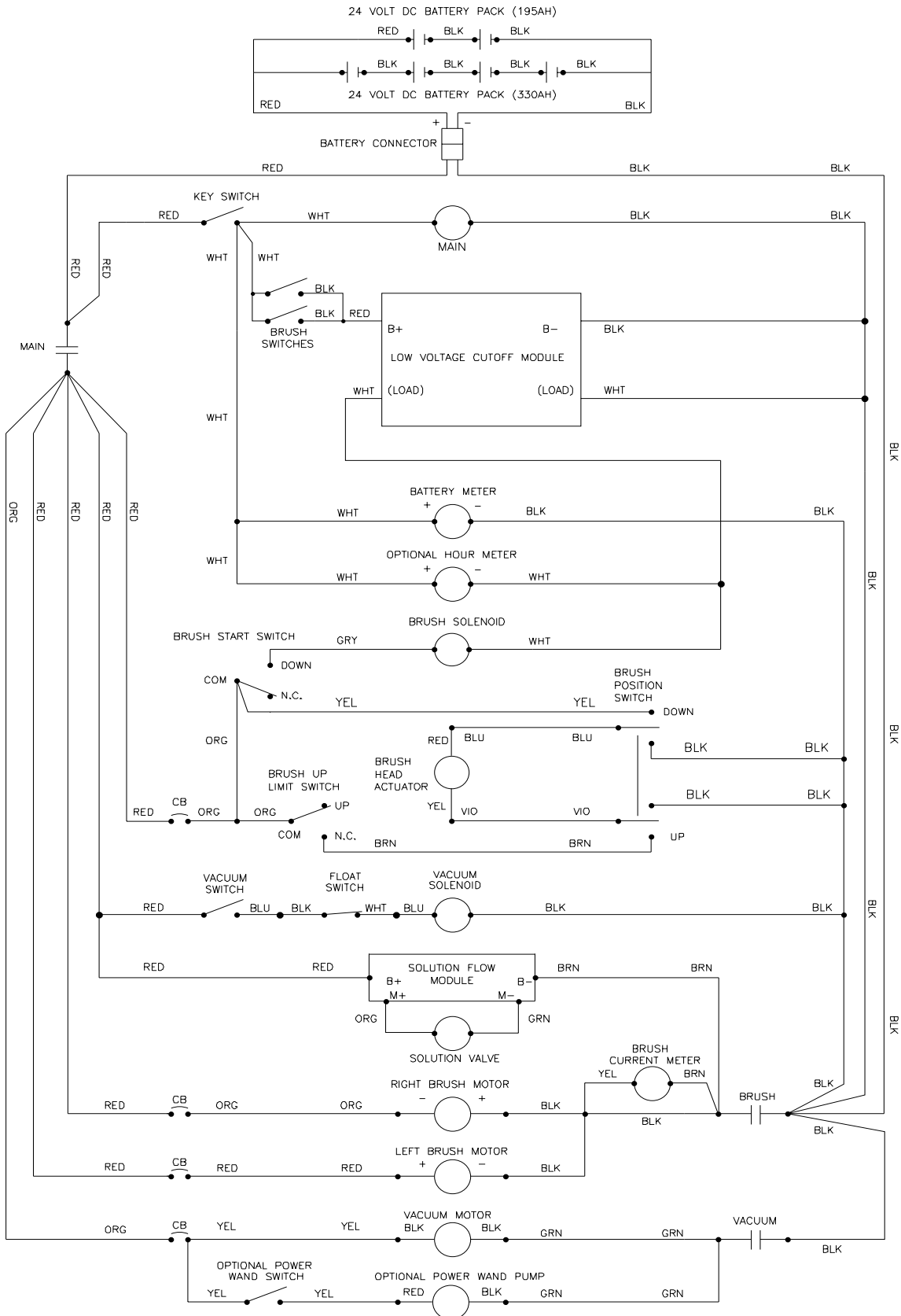

ALL BRUSH SWITCHES ARE SHOWN IN THE BRUSH HEAD UP POSITION.

CLARKE TECHNOLOGY

Encore L2426

Connection Diagram (00950A - W) 6/00

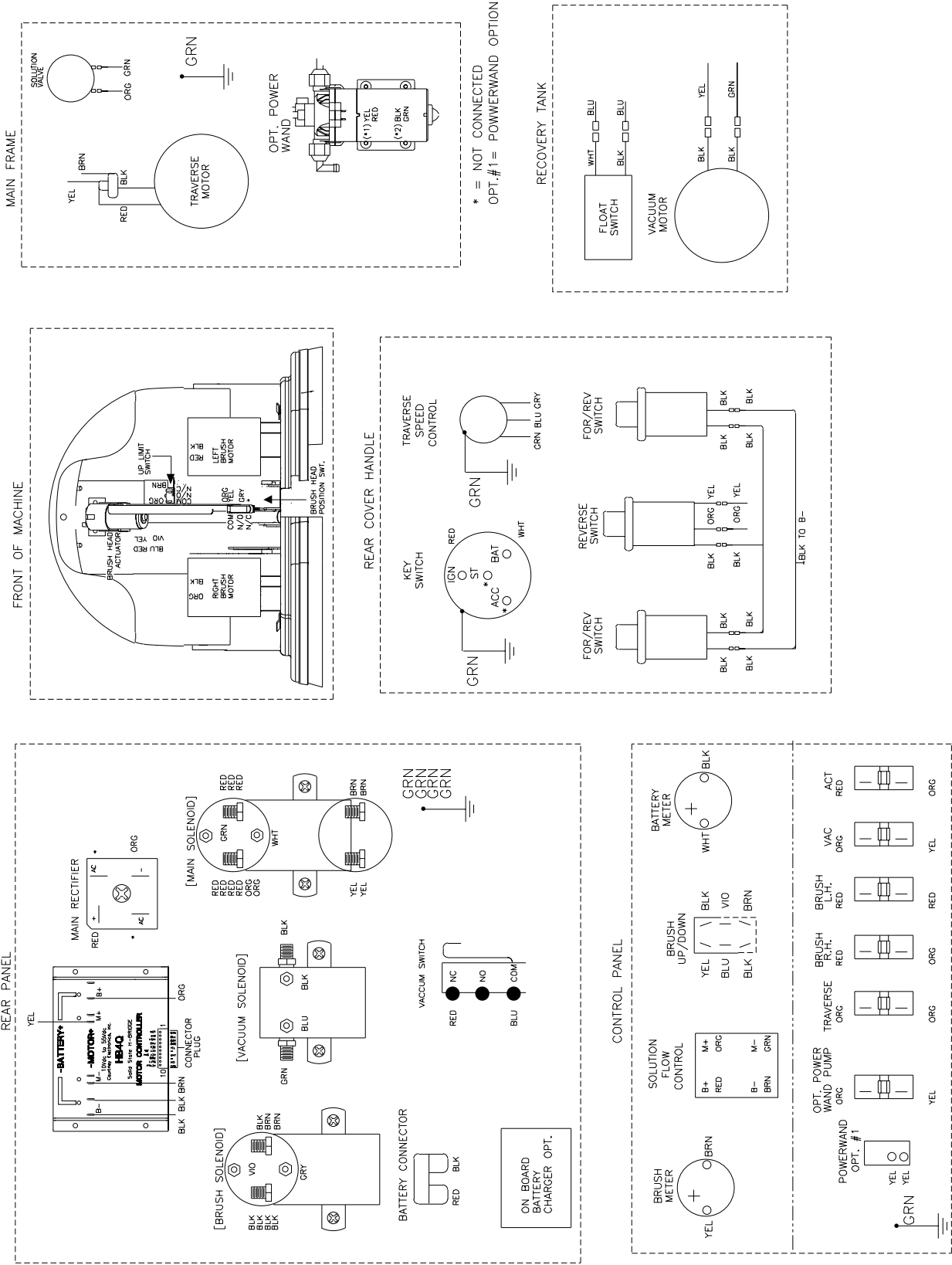

CLARKE TECHNOLOGY

Encore L2426

Electrical Schematic (00950A-E) 5/01

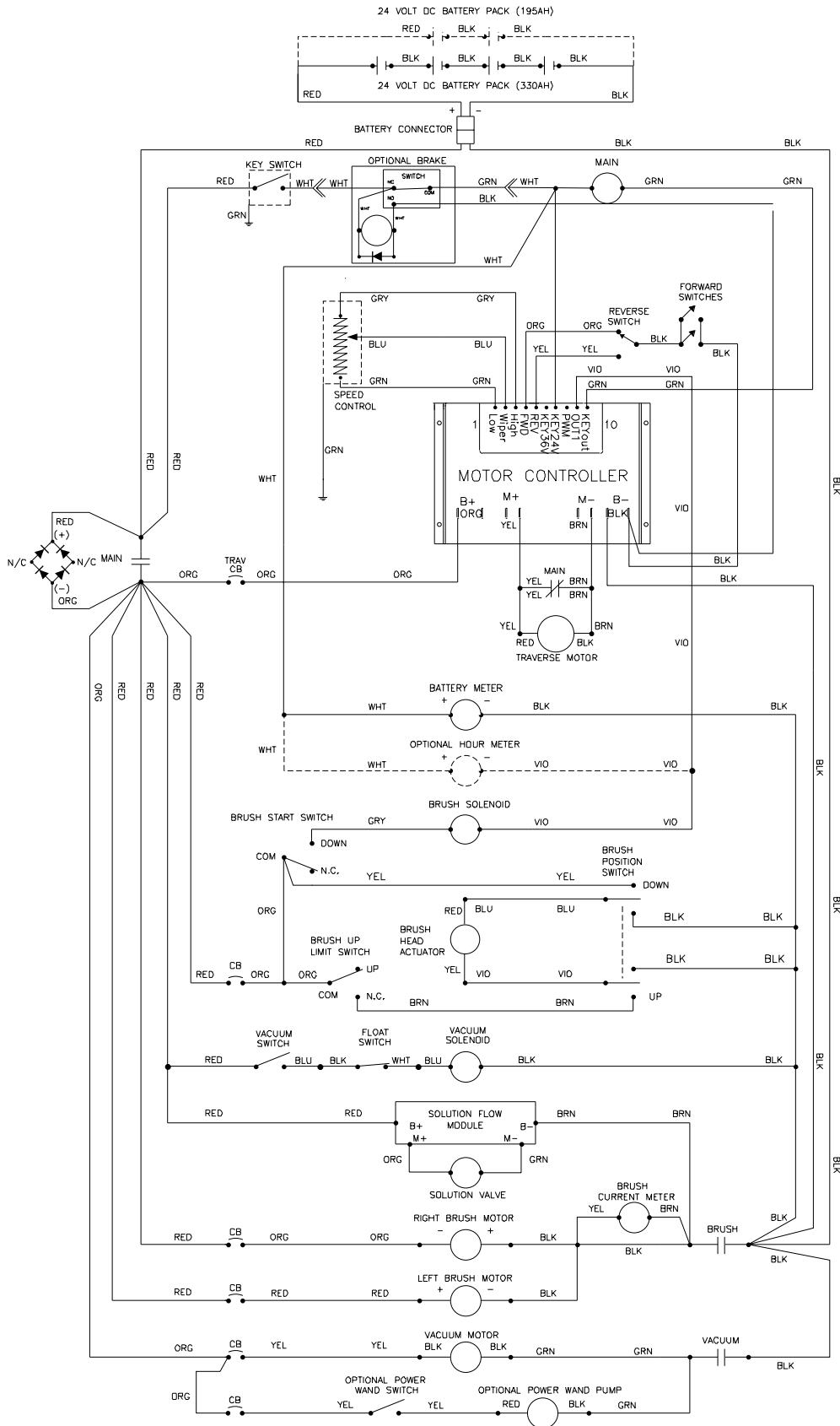

ALL BRUSH SWITCHES ARE SHOWN IN THE BRUSH HEAD UP POSITION.

ALTO® PRODUCT SUPPORT BRANCHES

U. S. A. Locations

HEAD OFFICE

ALTO U.S. Inc., St. Louis, Missouri
16253 Swingley Ridge Road, Suite 200
Chesterfield, Missouri 63017-1725

PRODUCTION FACILITIES

ALTO U.S. Inc., Springdale, Arkansas
2100 Highway 265
Springdale, Arkansas 72764
(501) 750-1000

Customer Service - 1-800-253-0367
Technical Service - 1-800-356-7274

ALTO U.S. Inc., Bowling Green, Ohio 43402
1100 Haskins

ALTO U.S. Inc., Clearwater, Florida 33765
1500 N. Belcher Road

SERVICE FACILITIES

ALTO U.S. Inc., Carlstadt, New Jersey 07072
150 Commerce Road
(201) 460-4774

ALTO U.S. Inc., Elk Grove, Illinois 60007
2280 Elmhurst Road
(847) 956-7900

ALTO U.S. Inc., Denver, Colorado 80204
1955 West 13th Ave.
(303) 623-4367

ALTO U.S. Inc., Houston, Texas 77040
7215 North Gessner Road

SALES AND SERVICE FACILITIES

ALTO U.S. Inc., Madison Heights, Michigan 48071-0158
29815 John R.
(810) 544-6300

ALTO U.S. Inc., Marietta, Georgia 30062
1355 West Oak Common Lane
(770) 973-5225

CLARKE TECHNOLOGY
AMERICAN SANDERS TECHNOLOGY
A.L. COOK TECHNOLOGY
Customer Service Headquarters and Factory

2100 Highway 265
Springdale, Arkansas 72764
(501) 750-1000

Technical Service
1-800-356-7274

European Locations

PRODUCTION FACILITIES

ALTO Danmark A/S, Aalborg
Blytaekervej 2
DK-9000 Aalborg
+45 72 18 21 00

ALTO Danmark A/S, Hadsund
Industrikvarteret
DK-9560 Hadsund
+45 72 18 21 00

SALES SUBSIDIARIES

ALTO Canada Ltd., Rexdale Ontario
24 Constellation Ct.
(416) 675-5830

ALTO Overseas Inc., Sydney (Australia)
1B/8 Resolution Drive
Caringbah NSW 2229
+61 2 9524 6122

ALTO Cleaning Systems Asia Pte Ltd., Singapore
No. 17 Link Road
Singapore 619034
+65 268 1006

ALTO Deutschland GmbH, Fronenberg (Germany)
Ardeyer Str. 15
D-58730 Fronenberg
+49 2373 754 200

ALTO Cleaning Systems (UK) Ltd., Penrith
Gilwilly Industrial Estate
Penrith
Cumbria CA11 9BN
+44 1768 868 995

ALTO France S.A. Strasbourg
B.P. 44, 4 Place d'Ostwald
F-67036 Strasbourg
Cedex 2
+33 3 8828 8400

ALTO Nederland B.V. Vianen
Stuurtweg 4C
NL-4131 NJ Vianen
+31 347 324000

ALTO Sverige AB, Molndal (Sweden)
Aminogatan 18
Box 4029
S-431 04 Molndal
+46 31 706 73 00

ALTO Norge A/S, Oslo (Norway)
Bjornerudveien 24
N-1266
+47 2275 1770

CLARKE TECHNOLOGY LIMITED U.S. WARRANTY

This Clarke Technology Industrial/Commercial Product is warranted to be free from defects in materials and workmanship under normal use and service for a period of three years from the date of purchase, when operated and maintained in accordance with Clarke Technology's Maintenance and Operations instructions. Motors must be inspected for carbon motor brush wear at six-month intervals by an authorized Clarke Technology repair station. Failure to comply with the six-month inspection requirement or failure to replace worn motor brushes identified during the inspection will void the warranty on the motors. Cost of the six-month inspection and replacement of carbon motor brushes is the responsibility of the purchaser. In the event of a warranty claim on the motors, proof of inspection and any required motor brush replacement must be provided.

This warranty is extended only to the original purchaser for use of the product. It does not cover normal wear parts such as electrical cable, rubber parts, hoses and motor brushes.

Clarke Technology's liability under this warranty is limited to repair of the product and/or replacement of parts and is given to purchaser in lieu of all other remedies, including INCIDENTAL AND CONSEQUENTIAL DAMAGES.

THERE ARE NO EXPRESS WARRANTIES OTHER THAN THOSE SPECIFIED HEREIN. THERE ARE NO WARRANTIES WHICH EXTEND BEYOND THE DESCRIPTION OF THE FACE HEREOF. NO WARRANTIES, INCLUDING BUT NOT LIMITED TO WARRANTY OF MERCHANTABILITY, SHALL BE IMPLIED. A warranty registration card is provided with your Clarke Technology product. Return the card to assist Clarke Technology in providing the performance you expect from your new floor machine.

If a difficulty develops with the product, you should: a) Contact the nearest authorized Clarke Technology repair location or contact the Clarke Technology Service Operations Department, 2100 Highway 265, Springdale, Arkansas 72764, for the nearest authorized Clarke Technology repair location. Only these locations are authorized to make repairs to the product under this warranty. (b) Return the product to the nearest Clarke Technology repair location. Transportation charges to and from the repair location must be prepaid by the purchaser. Clarke Technology will repair the product and/or replace any defective parts with out charge within a reasonable time after receipt of the product.

ALTO U.S. Inc., 2100 Highway 265, Springdale, Arkansas 72764.

BATTERY WARRANTY

In addition to the items above, any original equipment Clarke Technology Battery which becomes unserviceable under normal use within a period of ninety (90) days from date of sale to the original user will be repaired or replaced with one of equal specification at our option, F.O.B. any authorized Clarke Technology Sales or Service Branch, with no charge to the user, except transportation costs. After expiration of the above ninety (90) day period, any battery which fails under normal use will be adjusted to the original user with a new battery of equal specification on an eighteen (18) months pro rate basis from the date of purchase. Adjustment will be determined using the then current list price, plus transportation costs.

Warranty is rendered null and void if battery is not kept filled to the proper level with DISTILLED WATER.

CLARKE TECHNOLOGY: POLYDUR® AUTOMATIC SCRUBBER SOLUTION AND RECOVERY TANK EIGHT-YEAR U.S. GUARANTEE

Your new Clarke Technology Encore 2426 has polydur Solution and Recovery Tanks. Polydur is a rotationally molded, low-density linear polyethylene that won't crack or dent, and withstands most corrosives and temperature extremes. Clarke Technology backs up your Polydur tanks with an eight-year guarantee. If a tank breaks or leaks under normal use within eight years of the date of purchase, it will be replaced free.

CLARKE TECHNOLOGY UNIBODY FRAME EIGHT-YEAR U.S. WARRANTY

Clarke Technology warrants the frame of the Encore 2426 for a period of eight years against defects in materials and workmanship under normal use and service.

**CLARKE TECHNOLOGY reserves the right to make changes or improvements to its machine without notice.
Always use genuine ClarkeTechnology Parts for repair.**



**CLARKE TECHNOLOGY
2100 Highway 265
Springdale, Arkansas, 72764**