

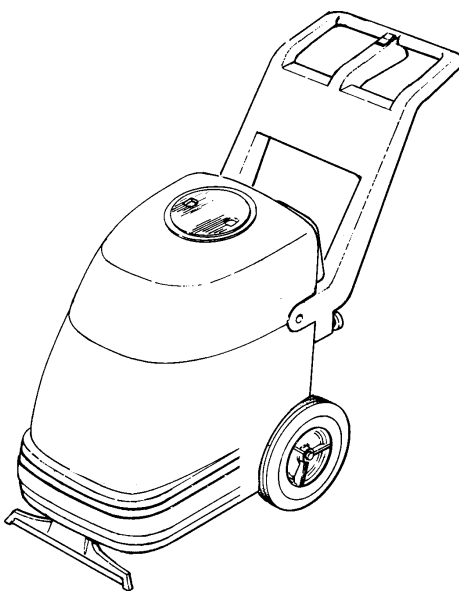

**Operator's
Manual**



**IMAGE 14
120V/230V**

READ THIS BOOK

This book has important information for the use and safe operation of this machine. Failure to read this book prior to operating or attempting any service or maintenance procedure to your Clarke machine could result in injury to you or to other personnel; damage to the machine or to other property could occur as well. You must have training in the operation of this machine before using it. If you or your operator(s) cannot read English, have this manual explained fully before attempting to operate this machine.

Si Ud. o sus operadores no pueden leer el Inglés, se hagan explicar este manual completamente antes de tratar el manejo o servicio de esta máquina.

All directions given in this book are as seen from the operator's position at the rear of the machine.

For new books write to: Clarke Industries Inc., 2100 Highway 265, Springdale, Arkansas 72764.

Table of Contents

Operator Safety Instructions 3
Introduction & Machine Specifications 5
Instructions - Power Supply 120 Volt 6
Instructions - Power Supply 230V 7
Machine Controls 8
How To Prepare the Machine for Operation 8
How to Clean Carpet 9
OPERATOR'S MAINTENANCE:
 How to Empty the Recovery Tank 10
 How to Empty the Solution Tank 10
 How to Attach the Auxiliary Floor Tool 11
 After Each Use of the Machine 11
 How to Prevent Damage from Freezing Temperatures 12
 Spray Bar Nozzle 12

SECTION II Parts and Service Manual

AUTHORIZED PERSONNEL MAINTENANCE

 To Access Pump/Brush Motor 14
 Brush Drive Belt Replacement 14
 Maintenance of the Vacuum Motor 14
 Brush maintenance 14
How to Correct Problems in the Machine 15
Final Assembly Drawing & Parts List Image 14 16
Handle Assembly Drawings & Parts List 17
Recovery Tank Assembly Drawing & Parts List 18
Solution Tank Assembly Drawing & Parts List 19
Brush/Pump Assembly Drawing & Parts List 20
Main Frame Assembly Drawing & Parts List 21
Pump Drawing & Parts List 22
Connection Diagram 120 Volts 23
Electrical Schematic 120 Volts 24
Connection Diagram 230 Volts 25
Electrical Schematic 230 Volts 26
Authentic Clarke Products 27

IMPORTANT SAFETY INSTRUCTIONS



WARNING



AVERTISSEMENT



ADVERTENCIA



DANGER:

Failure to read and observe all **DANGER** statements could result in severe bodily injury or death. Read and observe all **DANGER** statements found in your Owner's Manual and on your machine.



WARNING:

Failure to read and observe all **WARNING** statements could result in injury to you or to other personnel; property damage could occur as well. Read and observe all **WARNING** statements found in your Owner's Manual and on your machine.



CAUTION:

Failure to read and observe all **CAUTION** statements could result in damage to the machine or to other property. Read and observe all **CAUTION** statements found in your Owner's Manual and on your machine.



WARNING: To reduce the risk of fire, electric shock, or injury:

1. Do not leave appliance unattended when plugged in. Unplug from outlet when not in use and before servicing.
2. To reduce the risk of electric shock use indoors only.
3. Do not allow to be used as a toy. Close attention is necessary when used by or near children.
4. Use only as described in the manual. Use only manufacturer's recommended attachments.
5. Do not use with damaged cord or plug. If appliance is not working as it should, has been dropped, damaged, left outdoors, or dropped into water, return it to a service center.
6. Do not pull or carry by cord, use cord as a handle, close a door on cord, or pull cord around sharp edges or corners. Do not run appliance over cord. Keep cord away from heated surfaces.
7. Do not unplug by pulling on cord. To unplug, grasp the plug, not the cord.
8. Do not handle plug or appliance with wet hands.
9. Do not put any object into openings. Do not use with any opening blocked; keep free of dust, lint, hair and anything that may reduce air flow.
10. Keep hair, loose clothing, fingers, and all parts of body away from openings and moving parts.
11. Do not pick up anything that is burning or smoking, such as cigarettes, matches, or hot ashes.
12. Do not use without filters in place.
13. Turn off all controls before unplugging.
14. Use extra care when cleaning on stairs.
15. Do not use to pick up flammable or combustible liquids such as gasoline or use in areas where they may be present.
16. Connect to properly grounded outlet. See "Grounding Instructions".

SAVE THESE INSTRUCTIONS

IMPORTANTES MESURES DE SECURITE



AVERTISSEMENT: Pour réduire les risques d'incendie, de choc électrique ou de blessure:

1. Ne pas laisser l'appareil sans surveillance lorsqu'il est branché. Débrancher lorsque l'appareil n'est pas utilisé et avant l'entretien.
2. Pour réduire les risques de choc électrique, utiliser à l'intérieur seulement.
3. Ne pas permettre aux enfants de jouer avec l'appareil. Une attention particulière est
4. N'utiliser que conformément à cette notice avec les accessoires recommandés par le fabricant.
5. Ne pas utiliser si le cordon ou la fiche est endommagé. Retourner l'appareil à un atelier de réparation s'il ne fonctionne pas bien, s'il est tombé ou s'il a été endommagé, oublié à l'extérieur ou immergé.
6. Ne pas tirer soulever ou traîner l'appareil par le cordon. Ne pas utiliser le cordon comme une poignée, le coincer dans l'embrasure d'une porte ou l'appuyer contre des arêtes vives ou des coins. Ne pas faire rouler l'appareil sur le cordon. Garder le cordon à l'écart des surfaces chaudes.
7. Ne pas débrancher en tirant sur le cordon. Tirer plutôt la fiche.
8. Ne pas toucher la fiche ou l'appareil lorsque vos mains sont humides.
9. N'insérer aucun objet dans les ouvertures. Ne pas utiliser l'appareil lorsqu'une ouverture est bloquée. S'assurer que de la poussière, de la peluche, des cheveux ou d'autres matières ne réduisent pas le débit d'air.
10. Maintenir les cheveux, les vêtements amples, les doigts et toutes les parties du corps à l'écart des ouvertures et des pièces mobiles.
11. Ne pas aspirer de matières en combustion ou qui dégagent de la fumée, comme des cigarettes, des allumettes ou des cendres chaudes.
12. Ne pas utiliser l'appareil si le sac à poussière ou le filtre n'est pas en place.
13. Mettre toutes les commandes à la position ARRET avant de débrancher l'appareil.
14. User de prudence lors du nettoyage des escaliers.
15. Ne pas aspirer des liquides inflammables ou combustibles, comme de l'essence, et ne pas faire fonctionner dans des endroits où peuvent se trouver de tels liquides.
16. "Ne brancher qu'à une prise de courant avec mise à la terre. Voir les instructions visant la mise à la terre."

CONSERVER CES INSTRUCTIONS

- ⚠ DANGER:** Machines can cause an explosion when operated near flammable materials and vapors. Do not use this machine with or near fuels, grain dust, solvents, thinners, or other flammable materials.
- ⚠ WARNING:** You must have training in the operation of this machine before using it. **READ THE INSTRUCTION BOOK FIRST.**
- ⚠ WARNING:** Any alterations or modifications of this machine could result in damage to the machine or injury to the operator or other bystanders. Alterations or modifications not authorized by the manufacturer voids any and all warranties and liabilities.
- ⚠ WARNING:** Do not use this machine as a step or furniture. Injury could occur to the operator.
- ⚠ WARNING:** To avoid serious injury, use proper lifting procedures when lifting the machine.
- ⚠ WARNING:** Make sure that all the labels, decals, warnings, cautions and instructions are readable. Replace them when necessary by ordering them from Clarke.
- ⚠ WARNING:** Do not use water that is hotter than 140°F.
- ⚠ WARNING:** Improper discharge of waste water may damage the environment and be illegal. The United States Environmental Protection Agency has established certain regulations regarding discharge of waste water. Also, city and state regulation regarding this discharge may be in effect in your area. Understand and follow the regulations in your area. Be aware of the environmental hazards of chemicals that you dispose.

Introduction and Machine Specifications

The Image 14 is an extractor for cleaning carpet. The machine applies cleaning solution to the carpet and removes dirty solution and soil from the carpet. The Image 14 is equipped with a power brush. The extractor has controls to start the solution pump, and vacuum motor. This machine is intended for commercial use.

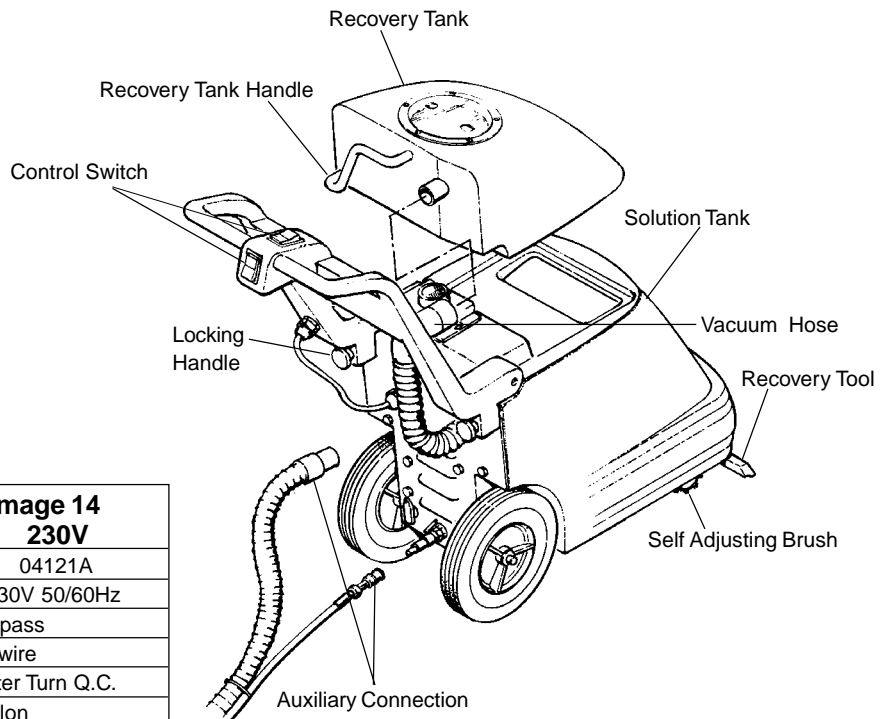

| Specifications: | Image 14 120V | Image 14 230V |
|-----------------------|---|------------------|
| Model | 04120A | 04121A |
| Electrical | 120 V. 50/60 Hz | 230V 50/60Hz |
| Solution Pump | 45 PSI Bypass | |
| Power Cable | 35' 14/3-wire | |
| Spray Jets | 1 Quarter Turn Q.C. | |
| Solution Tank Capacit | 4 Gallon | |
| Recovery Tank | 4 Gallon | |
| Waterlift/CFM | 82"/97 | |
| Vacuum | Tangential discharge, 1.25 HP, 2 stage | |
| Brush Size | 3½" x 11" | |
| Brush Motor Size | 1/8 HP | |
| Dimensions | 31½" x 37" x 14" | |
| Weight | 55 lbs. | |
| Shipping Weight | 65 lbs. | |

120 VOLT, 50/60 CYCLE MACHINES GROUNDING INSTRUCTIONS

This product must be grounded. If it should malfunction or breakdown, grounding provides a path of least resistance for electric current to reduce the risk of electric shock. This product is equipped with a cord having an equipment-grounding conductor and grounding plug. The plug must be inserted into an appropriate outlet that is properly installed and grounded in accordance with all local codes and ordinances.

⚠ WARNING: Improper connection of the equipment-grounding conductor can result in a risk of electric shock. Check with a qualified electrician or service person if you are in doubt as to whether the outlet is properly grounded. Do not modify the plug provided with the product - if it will not fit the outlet, have a proper outlet installed by a qualified electrician.

This product is for use on a nominal 120 volt circuit and has a grounding attachment plug that looks like the plug illustrated in Fig. 1. Make sure that the product is connected to an outlet having the same configuration as the plug. No adaptor should be used with this product.

For maximum protection against electric shock, use a circuit that is protected by a ground fault circuit interrupter. The green (or green and yellow) conductor in the cord is the ground wire. Never connect this wire to any terminal other than the ground terminal.

⚠ WARNING: To prevent possible electric shock, protect the machine from rain. Keep the machine in a dry building.

⚠ WARNING: To prevent possible electric shock, always use a 3-wire electrical system connected to the electrical ground. For maximum protection against electrical shock, use a circuit that is protected by a ground fault circuit interrupter. Consult your electrical contractor.

⚠ WARNING: Do not cut, remove or break the ground pin. If the outlet does not fit the plug, consult your electrical contractor.

⚠ WARNING: Have worn, cut, or damaged cords and plugs replaced by an authorized service person.

EXTENSION CORDS

Use only an approved extension cord with three conductors, a plug with three terminals, and a connector body with three holes. The machine has a power cord with wire size 14 AWG (AWG means American Wire Gauge).

⚠ WARNING: If you use an extension cord, use an extension cord with minimum wire size 14 AWG. Do not use an extension cord longer than 50 feet. Do not join two extension cords.

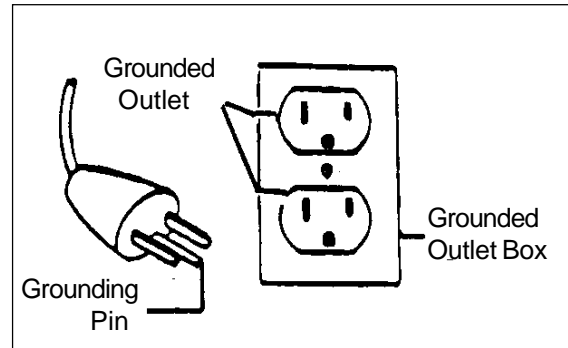

Figure 1

230 VOLT, 50/60 CYCLE MACHINES GROUNDING INSTRUCTIONS

CAUTION: This machine will operate only on AC frequency and electrical voltage shown on the nameplate. Make sure you have the correct frequency and voltage before connecting the power cord to an outlet.

This product must be grounded. If it should malfunction or breakdown, grounding provides a path of least resistance for electric current to reduce the risk of electric shock. This product is equipped with a cord having an equipment-grounding conductor and grounding plug. The plug must be inserted into an appropriate outlet that is properly installed and grounded in accordance with all local codes and ordinances.

WARNING: Improper connection of the equipment-grounding conductor can result in a risk of electric shock. Check with a qualified electrician or service person if you are in doubt as to whether the outlet is properly grounded. Do not modify the plug provided with the product - if it will not fit the outlet, have a proper outlet installed by a qualified electrician.

This product is for use on a nominal 230 volt circuit and has a grounding attachment plug that looks like the plug illustrated in Fig. 1A. Make sure that the product is connected to an outlet having the same configuration as the plug. No adaptor should be used with this product.

WARNING: To reduce the risk of fire, use only commercially available floor cleaners and waxes intended for machine application.

This machine is intended for commercial use.

This machine must be connected to the electrical ground to protect the operator from electrical shock. The machine has a power cord with two main conductors and one earthing conductor. Connect the plug to the receptacle. The green and yellow conductor in the cord is the ground wire. Never connect this wire to any terminal other than the ground terminal.

WARNING: Always use this machine with an AC three-conductor electrical system connected to the electrical ground. Replace any worn, cut or damaged cords. Replace any damaged plugs, receptacles, or connector bodies. Do not move the machine over an electrical cord. Always lift the cord over the machine.

EXTENSION CORDS

Use only an approved extension cord with two main conductors and one earthing conductor. The machine has a power cord with wire size 1.5mm².

WARNING: If you use an extension cord, use an extension cord with minimum wire size 1.5mm². Do not use an extension cord longer than 15 meters. Do not join two extension cords.

WARNING: Do not cut, remove or break the ground terminal. Do not try to fit a three-terminal plug into a receptacle or connector body that does not fit the plug. If the receptacle or connector body does not fit the plug, see your authorized Clarke dealer to get an authorized person to make the connection.

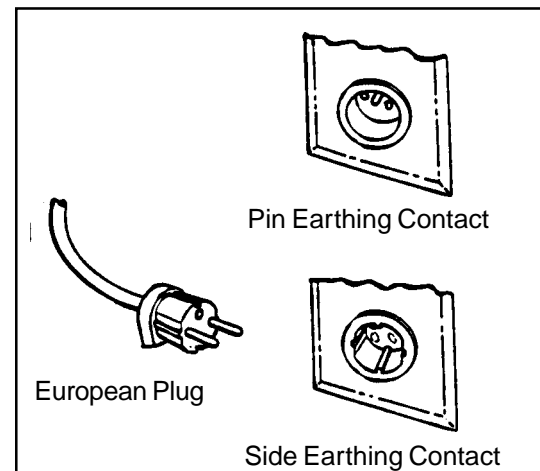

Figure 1A

THE CONTROLS

The Vacuum/Accessory/Pump Switch

This switch is located on the handle. To turn the vacuum motor on, place the switch in the middle position. To turn pump, brush, and vacuum motor on, place the switch in bottom position. (Figure 2, #1)

The Vacuum Hose Connector

The vacuum hose connector is on the right hand rear of the machine. (Figure 2, #2)

The Solution Hose Connector

The solution hose connector is located on the bottom center of the machine. This connection is used to hook up optional auxiliary floor tools. (Figure 2, #3)

Recovery Tank Drain

Remove hose from rear of machine. Using the handle lift the recovery tank free and pour water into drain.

Solution Tank Drain

Remove the hose from the rear of the machine. Place over drain.

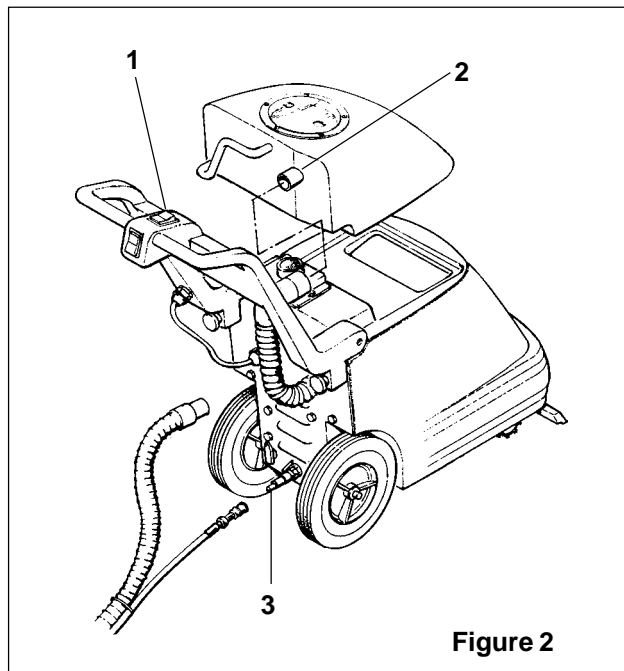

Figure 2

HOW TO PREPARE THE MACHINE FOR OPERATION

- ⚠ WARNING:** This machine has moving parts. To reduce the risk of injury, unplug before servicing.
- ⚠ WARNING:** To reduce the risk of fire, use only commercially available floor cleaners and waxes intended for machine application.
- ⚠ WARNING:** Do not use water that is hotter than 140°F.
- ⚠ WARNING:** Operating a machine that is not completely or fully assembled could result in injury or property damage. Do not operate this machine unless it is completely assembled. Inspect the machine carefully before operating.

- ⚠ CAUTION:** Do not leave the extractor or other cleaning machines or tools on the carpet when not in use. Cleaning solution in the machines and tools can leak onto the carpet and cause light spots or stains.

NOTE: To order Clarkare® Extractor Concentrate, Order Part No. 398421. To order Clarkare® Defoamer, order Part No. 398420. For instructions for preparation and operation of your floor tool, read the operator's manual supplied with your floor tool.

This machine is intended for commercial use.

To prepare the machine for operation, follow this procedure:

1. Before moving the extractor onto the carpet, put clean hot water into the solution tank. The solution tank capacity is approximately four gallons.
2. Add two to ten ounces of "Clarkare® Extractor concentrate" per every one gallon of water, depending on carpet condition.
3. If the extractor removes an excess amount of foam from the carpet, add a defoamer such as Clarkare® Defoamer Concentrate to the recovery tank. The amount needed will change according to the amount of detergent already in the carpet.

HOW TO CLEAN AN AREA OF CARPET

CAUTION: The recovery tank is equipped with a mechanical shut-off float switch. When the recovery tank becomes full the machine will no longer recover water. Turn the vacuum/accessory and spray/brush/switch to the "O" position before emptying the recovery tank.

NOTE: When using the extractor to clean carpets, follow this procedure:

1. Do not walk on freshly cleaned carpets for at least four hours or until the carpet is dry to touch.
2. If aluminum or plastic pieces have been placed under the legs of furniture, do not remove them until the carpet is dry.
3. Do not allow children or pets to crawl or walk around on the damp carpet.
4. Vacuum right after the carpet is dry and then vacuum the carpet once a week, or as often as needed.

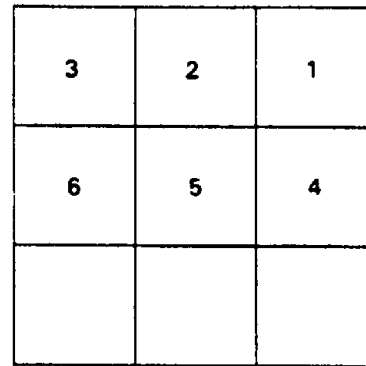

Figure 3

To clean an area of carpet, follow this procedure:
(See Figure 3)

1. Dry Vacuum area of carpet to be cleaned.
2. Turn the Vacuum switch to the "ON" position.
3. Brush will self adjust.
NOTE: Incorrect brush height may cause circuit breaker to trip. Check for obstructions in brush housing, clear and proceed.
4. With the pump switch activated, slowly and steadily pull the machine backwards.
5. Switch to Pump "OFF" and vacuum an additional 6 inches.
6. To clean a small area of carpet, clean the carpet in sections three feet square. As you make additional passes, overlap one inch of the area already cleaned.
7. Cleaning speed is determined by how dirty the carpet is. If the carpet is very dirty, move the machine slower.
8. As the machine is used, dirty solution will begin to fill the recovery tank. When the solution tank is empty, the recovery tank must be emptied.

To clean a larger area of carpet, follow this procedure:
(See Figure 4)

1. Begin at the right-hand corner of the carpet.
2. Make a pass halfway along the edge of the carpet. Pull the machine backward at a steady speed.
3. Move to the edge of the carpet. Make another pass next to your first pass.
4. As you make more passes, overlap one inch of the area already cleaned. Make each pass four inches different in length to prevent making a line in the center of the carpet.
5. Make more passes until half of the carpet is cleaned.
6. Move to the right hand corner of the carpet not yet cleaned.
7. Make a pass halfway along the edge of the carpet.
8. As you make passes, overlap one inch of the area already cleaned.
9. Make more passes until all of the room is cleaned.

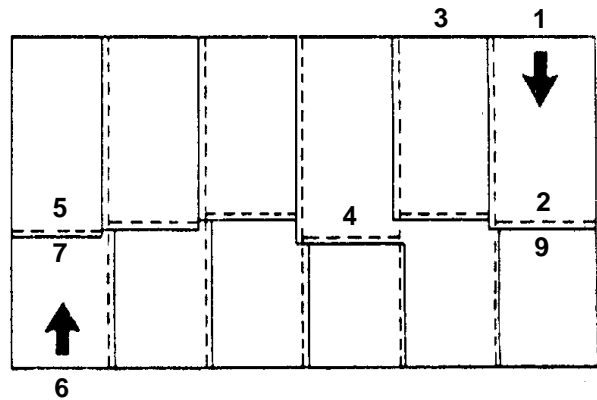

Figure 4

CAUTION: Clarke will not be held liable for damage to the carpet, or poor results because of the operator's lack of ability.

OPERATOR'S MAINTENANCE

How to Empty the Recovery Tank

To empty the recovery tank, follow this procedure:

1. Turn the switches on the machine to the "O" position.
2. Remove the hose on the rear of the recovery tank. Lift recovery tank by handle and carry to drain.
3. Using drain spout, pour into drain.

How to Empty the Solution Tank

1. Turn switches to the "O" position.
2. Position the machine near a drain. Remove the hose from the rear of the machine and place hose into drain.

How To Attach The Auxiliary Floor Tool

To attach the auxiliary floor tool, follow this procedure:

1. Remove the vacuum hose from the recovery tank.
2. Connect the auxiliary floor tool vacuum hose to the recovery tank and to the auxiliary tool.
3. Move and hold the brush height lever (figure 5) away from the auxiliary connection. Make connection and release brush height lever (will rest against connection). See figure 5a.
4. Connect the solution hose to the machine and to the floor tool.
5. Turn solution valve to accessory position.
6. Turn the vacuum and pump switch "ON".
7. Operate the optional cleaning tool as normal.
8. When finished cleaning with the optional floor tool, turn the switches "OFF".

NOTE: Auxiliary floor tools recommended for this machine:

- 19209A - RM4 (Upholstery)
- 19212A - RM9 (9" Floor Wand)
- 785401 - RM10 (10" Floor Wand)
- 59220A - Plastic Hand Tool 4" (Upholstery)

NOTE: For maintenance of the optional floor tools, read the manual supplied with the tools.

After Each Use Of The Machine:

1. To prevent damage to valves and jets, flush one gallon of clean water through the solution system and the tools.
2. Disconnect the power cord from the outlet and wrap around the handle.
3. Drain the recovery tank.
4. Rinse out the recovery tank.
5. Use a dry cloth to wipe both tanks and tools, inside and out.
6. Inspect and clean the screen filter in the solution tank.
7. To prevent clogged jets due to alkaline buildup, the spray system should be flushed at least twice a month with either a white vinegar solution (one quart vinegar to one gallon of hot water) or an anti-browning solution (mixed as directed).
8. Remove any lint on the vacuum intake screen. The screen is located under the recovery tank and on the rear of the machine.

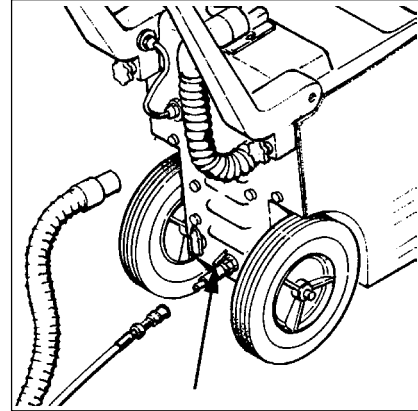

Figure 5

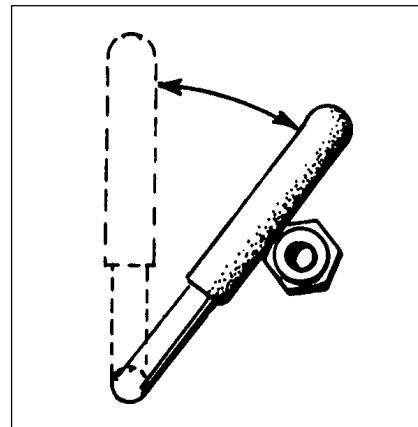

Figure 5a

How to Prevent Damage From Freezing Temperatures

To prevent damage from freezing temperatures, follow this procedure:

1. Remove any solution remaining in the solution tank.
2. Make sure the machine and pump are completely dry.
3. Pour windshield-type antifreeze into the solution tank until the screen in the filter is covered.
4. Turn on the vacuum/accessory switch and the spray/brush switch for 30 seconds.
5. Remove antifreeze solution from the system before using the extractor.
6. Make sure the machine is the same temperature as the room before using the machine.

Spray Bar - Nozzles

To clean or quick change the nozzles follow this procedure:

1. Grasp the nozzle, push in and twist 1/4 of a turn to remove nozzle from the body.
2. Clean or replace the nozzle.
4. Push in and twist nozzle back into the body.

NOTE: Performance will drop if the factory nozzle configuration is changed.

 **WARNING:** Maintenance and repairs must be done by authorized personnel only. Keep all fasteners tight. Use only Clarke parts. Maintenance performed by someone other than a Clarke distributor or Clarke replacement parts could void your warranty.

Electrical

 **WARNING:** Electrical repairs must be done by authorized personnel only.

 **WARNING:** After electrical repairs are done to the machine, the machine must be tested for electrical safety.



Image 14

Section II

Parts and Service Manual

(79086B)

To Access Pump/Brush Unit

1. Remove six (6) screws in rear plate that secure solution tank to machine.
2. Remove solution tank from machine.
3. Disconnect pump ground wire from ground screw.
4. Remove solution hoses.
5. Remove two (2) mounting screws that secure pump motor to frame.
6. Reverse procedures for installing new pump. Check wiring diagram for proper connections when re-installing electrical parts.

Brush Drive Belt Replacement

1. Remove (6) screws in rear plate that secure solution tank to machine.
2. Remove solution tank from machine.
3. Remove screws holding brush cover on. Remove brush cover.
4. Remove (2) screws holding brush assembly in place and replace belt.
5. Reassemble in reverse order.

Maintenance of the Vacuum Motor

This machine has a vacuum motor that uses carbon brushes. The carbon brushes in the motor must be checked every three months, or every 500 hours of operation, whichever comes first. If either of the brushes is shorter than 3/8 inch, replace both of the carbon brushes.

To gain access to the vacuum motor:

1. Remove (6) screws in rear plate that secure solution tank to machine.
2. Remove solution tank from machine.
3. Access the brushes or the (3) bolts that secure the vacuum motor to tank.

Brush Maintenance

1. Remove (6) screws in rear plate that secure solution tank to machine.
2. Remove solution tank from machine.
3. Remove screws holding brush cover on. Remove brush cover.
4. Remove (2) screws holding brush assembly in place and replace brush.
5. **Carefully** pry brush pivot out from bearing (applying pressure unevenly can break brush pivot).
6. Add a small amount of grease to face of seal and bearing on I.D. of brush core.
7. Reassemble in reverse order.

HOW TO CORRECT PROBLEMS IN THE MACHINE

| PROBLEM | CAUSE | ACTION |
|--|---|--|
| The machine will not run. | 1. Machine does not have power... | 1. Make sure the machine is connected to the correct frequency and voltage, and all connections are tight. |
| There is no suction. | 1. Vacuum motor may not be running... | 1. Be sure the vacuum/accessory switch is at the vacuum/accessory position. |
| | 2. Vacuum intake screen clogged. | 2. Remove and clean lint screen on vacuum stand pipe. |
| | 3. There may be a loose motor connection. | 3. Contact an authorized service person. |
| | 4. There may be an obstruction in the vacuum hose.... | 4. Remove the obstruction. |
| | 5. Motor brushes may be worn... | 5. Replace the motor brushes. |
| | 6. Drain may be open... | 6. Connect recovery hose. |
| | 7. Dome may be worn or damaged... | 7. Replace the gasket or dome. |
| | 8. Vacuum hose may be damaged... | 8. Replace the hose. |
| | 9. Vacuum/Accessory switch may be defective..... | 9. Contact an authorized service person. |
| Uneven or no spray from the jets. | 1. The Accessory/Floor valve may be in wrong position.. | 1. Turn the valve to Floor position. |
| | 2. The spray tip may be dirty, plugged or worn... | 2. Clean or replace the tip. |
| | 3. The hose may be kinked... | 3. Inspect the hose. |
| | 4. Inline filter may be plugged... | 4. Clean filter. |
| | 5. Out of solution... | 5. Add solution to tank. |
| The solution pump runs but no solution comes out of the spray nozzle. | 1. The spray tips may be plugged... | 1. Clean the spray tips. |
| | 2. The solution screen may be plugged... | 3. Clean and replace. |
| | 3. The pump may be worn... | 4. Contact an authorized service person. |
| | 4. The hose may be kinked... | 5. Inspect the hose. |
| The solution pump leaks. | 1. There may be a faulty seal in the pump.. | 1. Contact an authorized service person. |
| | 2. The pump may be worn.... | 2. Contact an authorized service person. |
| The float switch may not be shutting off or turning on. | 1. The ball may be damaged or obstructed | 1. Inspect and clear obstruction. |
| Brush motor doesn't run. | 1. Circuit breaker tripped... | 1. Reset circuit breaker. |
| | 2. Switch is bad... | 2. Contact an authorized service person. |
| | 3. Motor is bad.... | 3. Contact an authorized service person. |
| | 4. Belt is broken.... | 4. Contact an authorized service person. |

CLARKE TECHNOLOGY Image 14
Drawing and Parts List Final Assembly 4/98

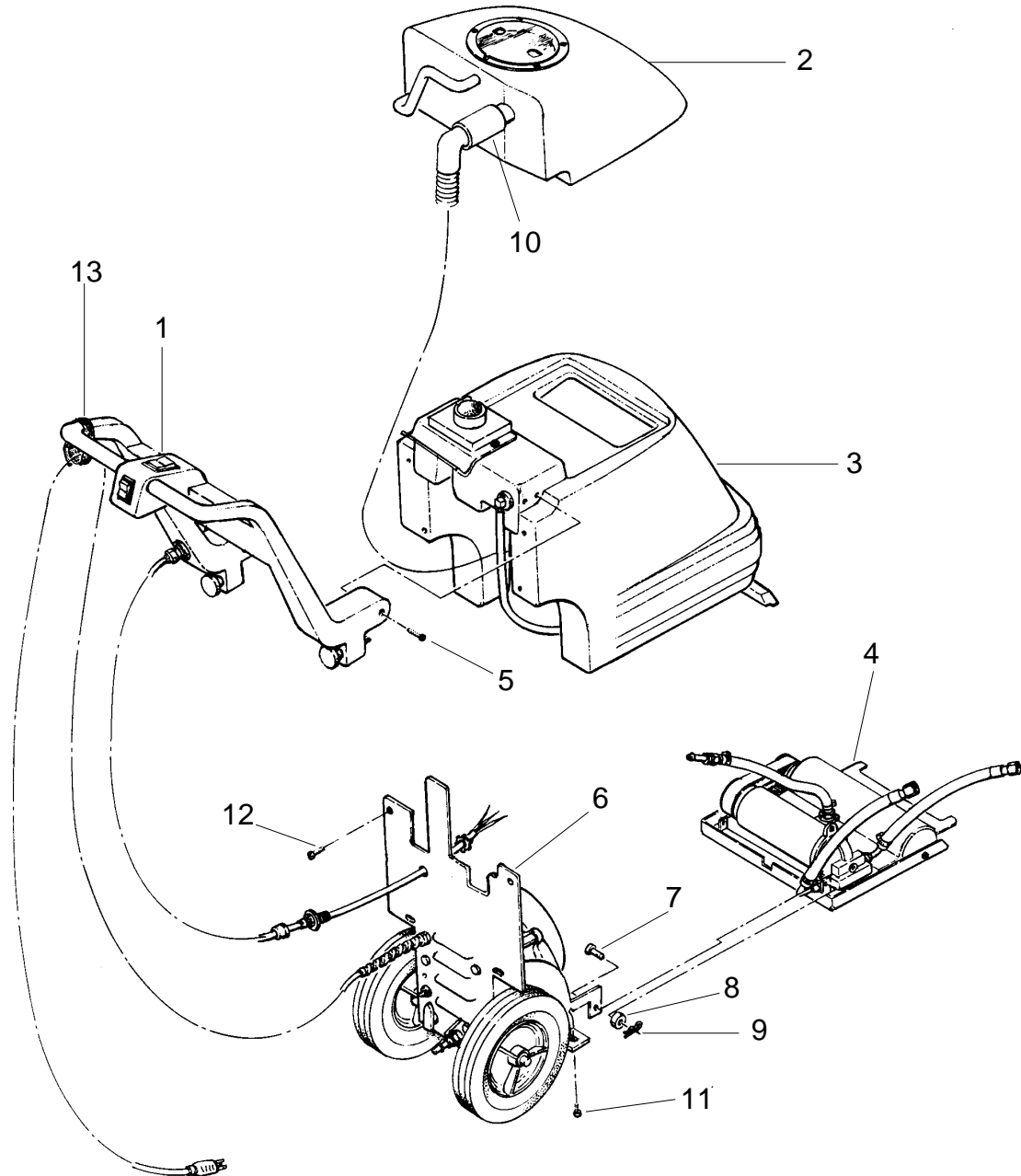

| Ref. | Part No. | Description | Qty |
|------|----------|-------------------------|-----|
| 1 | Page 15 | Handle Assembly | 1 |
| 2 | Page 16 | Recovery Tank Assembly | 1 |
| 3 | Page 17 | Solution Tank Assembly | 1 |
| 4 | Page 18 | Brush/Pump Assembly | 1 |
| 5 | 80013A | Bolt, Shoulder | 2 |
| 6 | Page 19 | Main Frame Assembly | 1 |
| 7 | 82509A | Pin, Clevis | 2 |
| 8 | 58540A | Spacer | 2 |
| 9 | 925004 | Pin, Cotter | 2 |
| 10 | 68504A | Drain, Preventor | 1 |
| 11 | 85397A | Screw, 10-24 x 3/8 S.S. | 2 |
| 12 | 85398A | Screw, 1/4-20 S.S. | 4 |
| 13 | 57427A | Retainer, PowerCord | 1 |

CLARKE TECHNOLOGY Image 14
Drawing & Parts List, Handle Assembly 4/98
Form #15347A

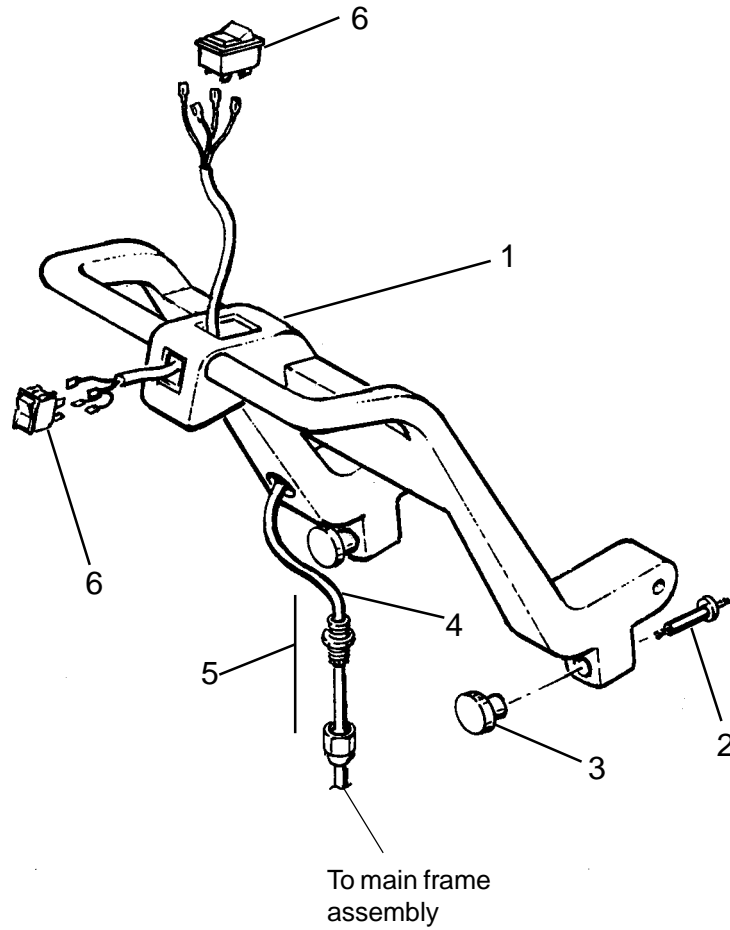

| Ref. | Part No. | Description | Qty |
|------|----------|-----------------------------------|-----|
| 1 | 34811B | Handle, Control | 1 |
| 2 | 57002A | Post, Knob | 2 |
| 3 | 55538A | Knob, Handle Lock | 2 |
| 4 | 49761B | Harness, Wiring | 1 |
| 5 | 56459A | Strain Relief (supplied w/item 4) | 1 |
| 6 | 47411A | Switch, Control | 2 |

CLARKE TECHNOLOGY Image 14
Drawing and Parts List, Recovery Tank Assembly 10/98
Form #19014A

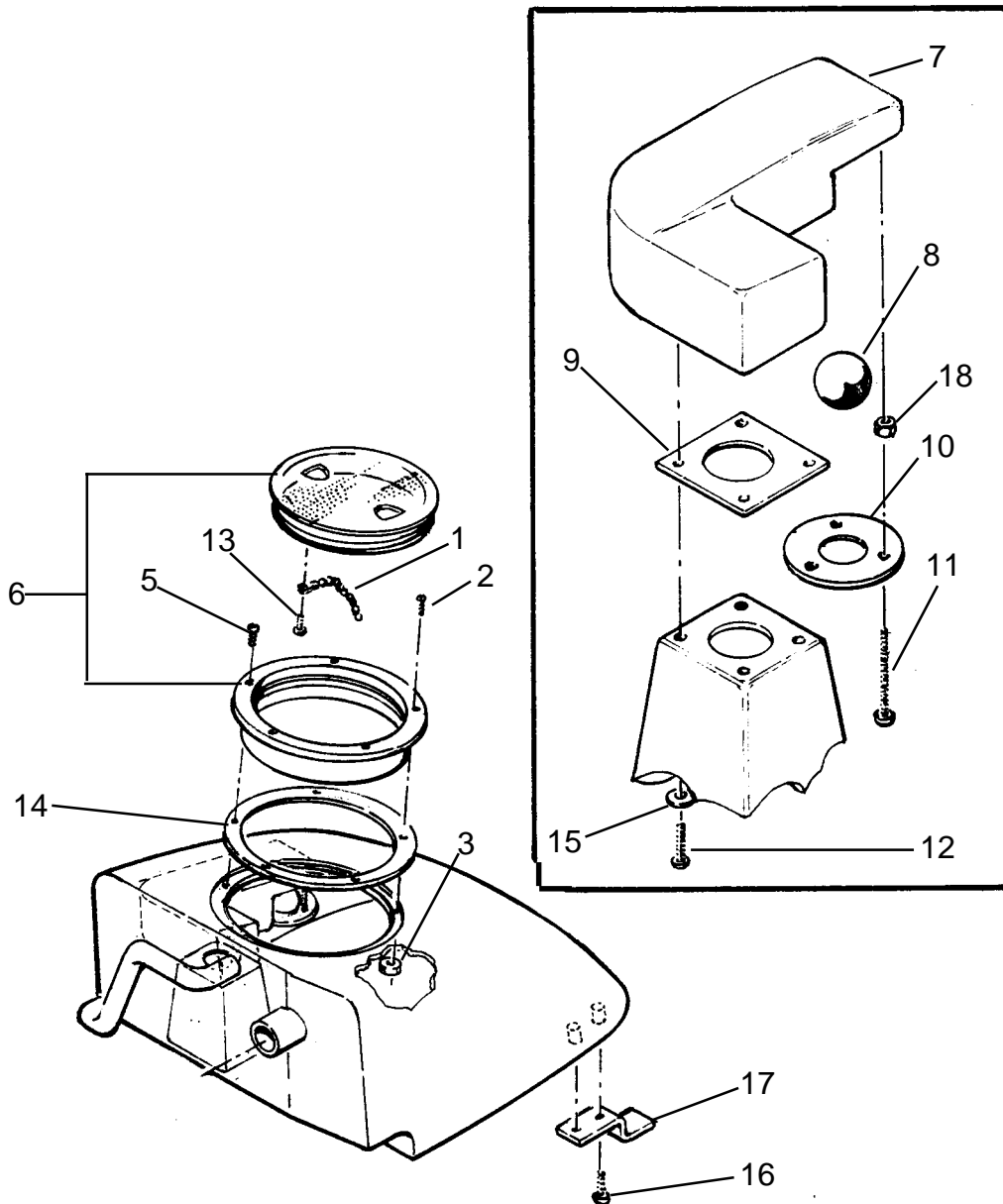

| Ref. | Part No. | Description | Qty |
|------|----------|-----------------------------|-----|
| 1 | 692409 | Chain, Cover | 1 |
| 2 | 86303A | Screw, #10-24 x 1.25 | 1 |
| 3 | 81901A | Nut, #10-24 | 1 |
| 4 | 38809B | Tank, Recovery | 1 |
| 5 | 962954 | Screw, 10-24 x 3/8 | 4 |
| 6 | 55670A | Lid, Recovery | 1 |
| 7 | 31803A | Chamber, Vac | 1 |
| 8 | 50805A | Ball, Float Shut Off | 1 |
| 9 | 34286A | Gasket, Vac Chamber | 1 |
| 10 | 57425A | Retainer, Flat | 1 |
| 11 | 85606A | Screw, 10-32 x 3" Pan Hd SS | 3 |
| 12 | 84237A | Screw, 10-32 x 1/2 | 4 |
| 13 | 962987 | Screw, Hi-Lo | 1 |
| 14 | 34288A | Gasket, Recovery Lid | 1 |
| 15 | 980982 | Washer, #10 | 4 |
| 16 | 85397A | Screw | 2 |
| 17 | 69893A | Bracket, Retaining | 1 |
| 18 | 920224 | Nut | 1 |

CLARKE TECHNOLOGY Image 14
Drawing and Parts List, Solution Tank Assembly 10/98
Form #19013A

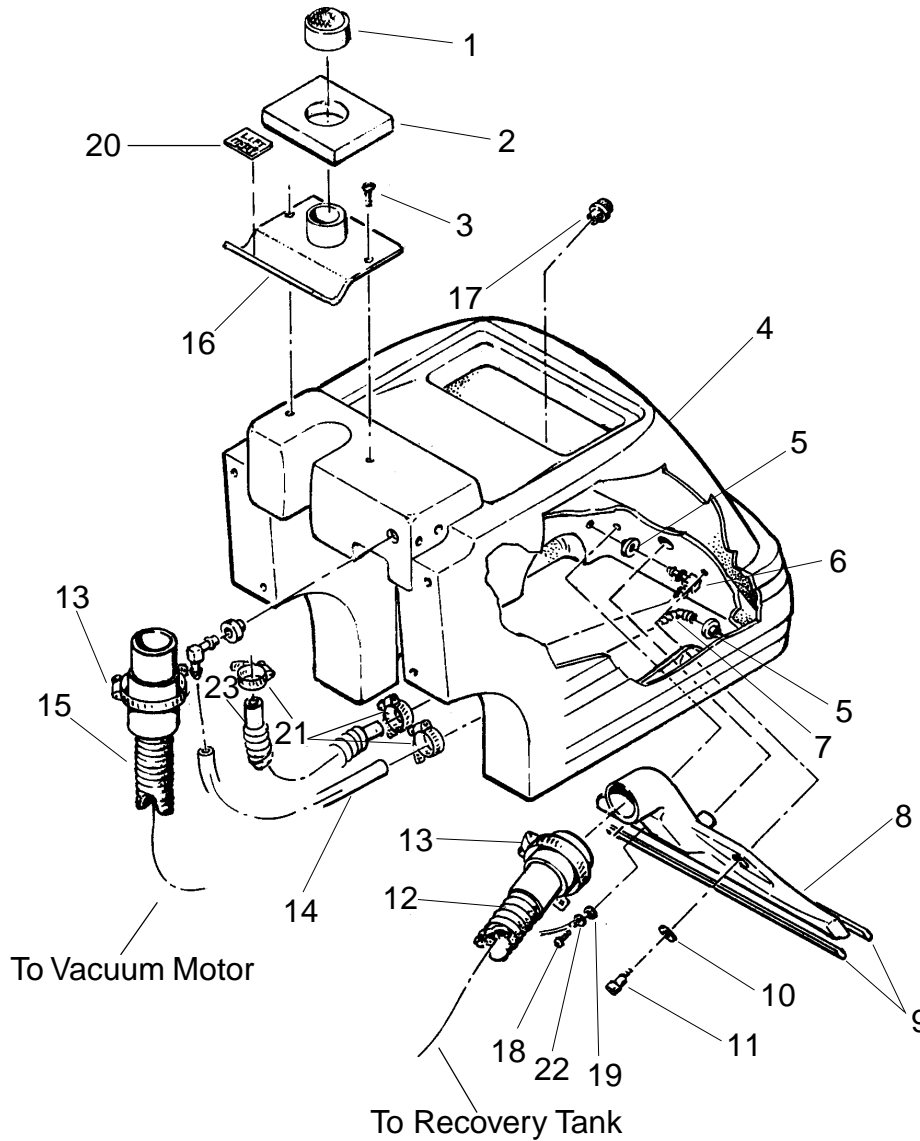

| Ref. | Part No. | Description | Qty |
|------|----------|--|-----|
| 1 | 56476A | Strainer, Vacuum | 1 |
| 2 | 54371A | Gasket, Vac | 1 |
| 3 | 85398A | Screw | 2 |
| 4 | 38808B | Tank, Solution | 1 |
| 5 | 51518A* | Bushing | 3 |
| 6 | 52417A* | Connector, $\frac{3}{8}$ x $\frac{1}{4}$ | 1 |
| 7 | 52414A | Connector, Hose | 2 |
| 8 | 28205A | Tool, Recovery | 1 |
| 9 | 67616A | Shoe, Recovery | 2 |
| 10 | 87026A | Washer, S.S. | 2 |
| 11 | 80018A | Shoulder Bolt | 2 |
| 12 | 55166A | Hose, Recovery | 1 |
| 13 | 872010 | Clamp, Hose | 3 |
| 14 | 30441A | Hose, Solution Drain | 1 |
| 15 | 30419A | See Page 19, #12 | |
| 16 | 60321A | Adaptor, Weldment | 1 |
| 17 | 58068A | Screen, Solution | 1 |
| 18 | 962333 | Screw | 2 |
| 19 | 980603 | Washer, Lock | 1 |
| 20 | 73379A | Label, Lift Here | 1 |
| 21 | 722021 | Clamp, Hose #4 | 3 |
| 22 | 48911A | Wire, Ground | 1 |
| 23 | 35138A | Hose | 1 |

*Note: Service Item Only

CLARKE TECHNOLOGY Image 14
Drawing and Parts List, Brush/Pump Assembly 9/01
Form #17651A

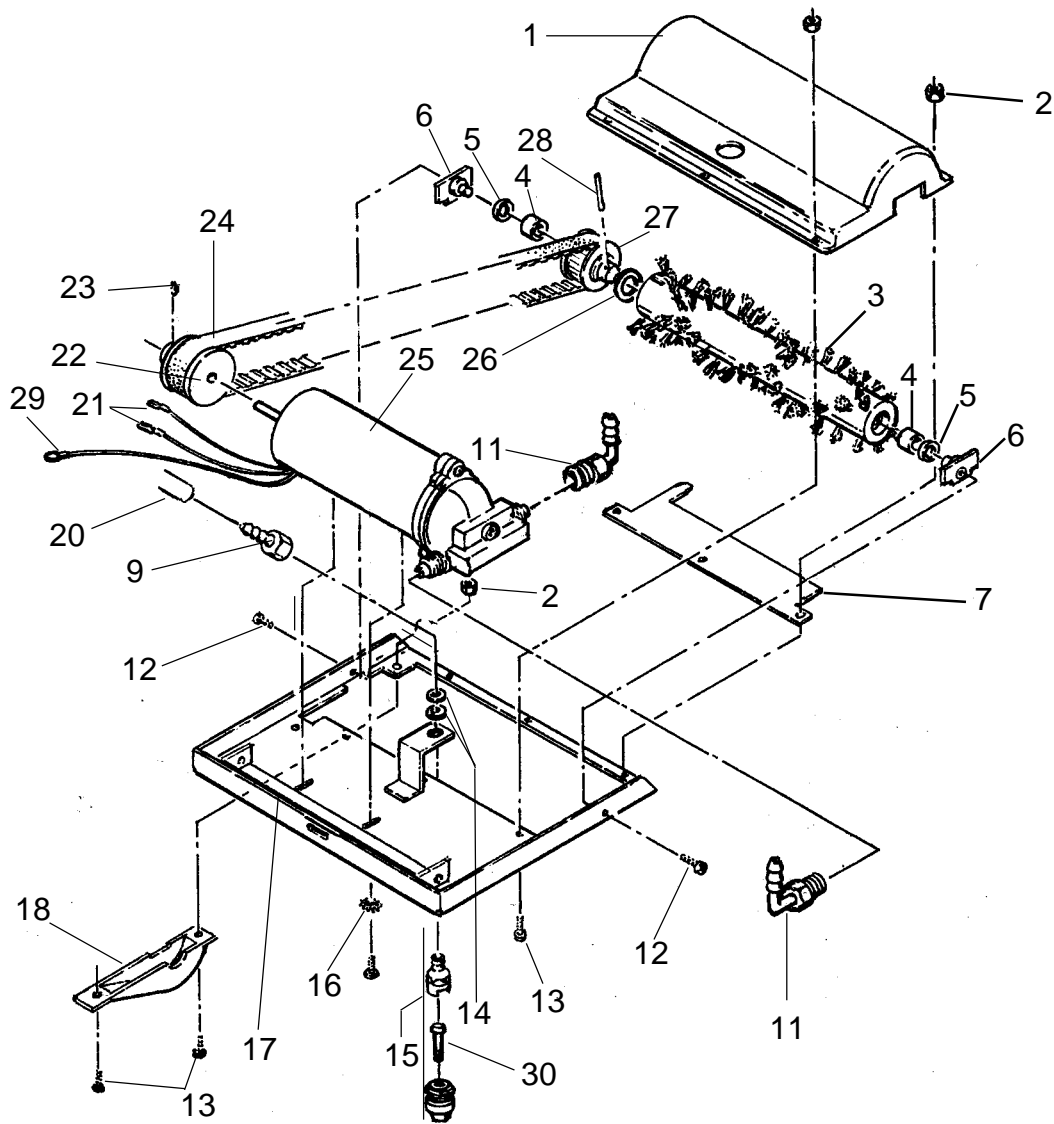

| Ref. | Part No. | Description | Qty |
|------|----------|-------------------------------|-----|
| 1 | 32400A | Cover, Brush | 1 |
| 2 | 920056 | Nut, 6 x 32 Elastic | 7 |
| 3 | 51713A | Brush, Carpet | 1 |
| 4 | 902648 | Brg, Ball Radial | 2 |
| 5 | 53047A | Seal | 2 |
| 6 | 66221A | Pivot, Brush | 2 |
| 7 | 34110A | Guard, Splash | 1 |
| 9 | 55167A | Hosebarb, 1/4 x 3/8 | 1 |
| 11 | 53616A | Elbow, 3/8 MPT x 3/8 Hosebarb | 2 |
| 12 | 85837A | Screw, 10-24 x 1/4 Pn. Hd. | 2 |
| 13 | 85607A | Screw, 6-32 x 3/8 | 7 |
| 14 | 980410 | Washer, Stainless Steel | 2 |
| 15 | 54169A | Nozzle, Spray | 1 |
| 16 | 980603 | Washer, Star | 2 |

| Ref. | Part No. | Description | Qty |
|------|----------|----------------------|-----|
| 17 | 63535A | Frame, Brush/Pump | 1 |
| 18 | 32408A | Guard, Pulley | 1 |
| 20 | 35147A | See page 19 ref. #45 | |
| 21 | 47711A | Terminal, 1/4 FIFQD | 2 |
| 22 | 57271A | Pulley, Timing | 1 |
| 23 | 962628 | Screw, Set | 2 |
| 24 | 50926A | Belt, Timing | 1 |
| 25 | 51714A | Brush/Pump Unit 120V | 1 |
| | 51719A | Brush/Pump Unit 230V | 1 |
| 26 | 980202 | Washer, Wave | 1 |
| 27 | 66187B | Sprocket | 1 |
| 28 | 925549 | Pin, 3/16 x 1 1/2 | 1 |
| 29 | 911933 | Terminal | 1 |
| 30◆ | 30078A* | Stainer, Spray Jet | 1 |

NOTE: ◆ indicates a change has been made since last publication of this manual.

* Optional Accessory

CLARKE TECHNOLOGY Image 14
Drawing and Parts List, Main Frame Assembly 9/01
Form #17650A

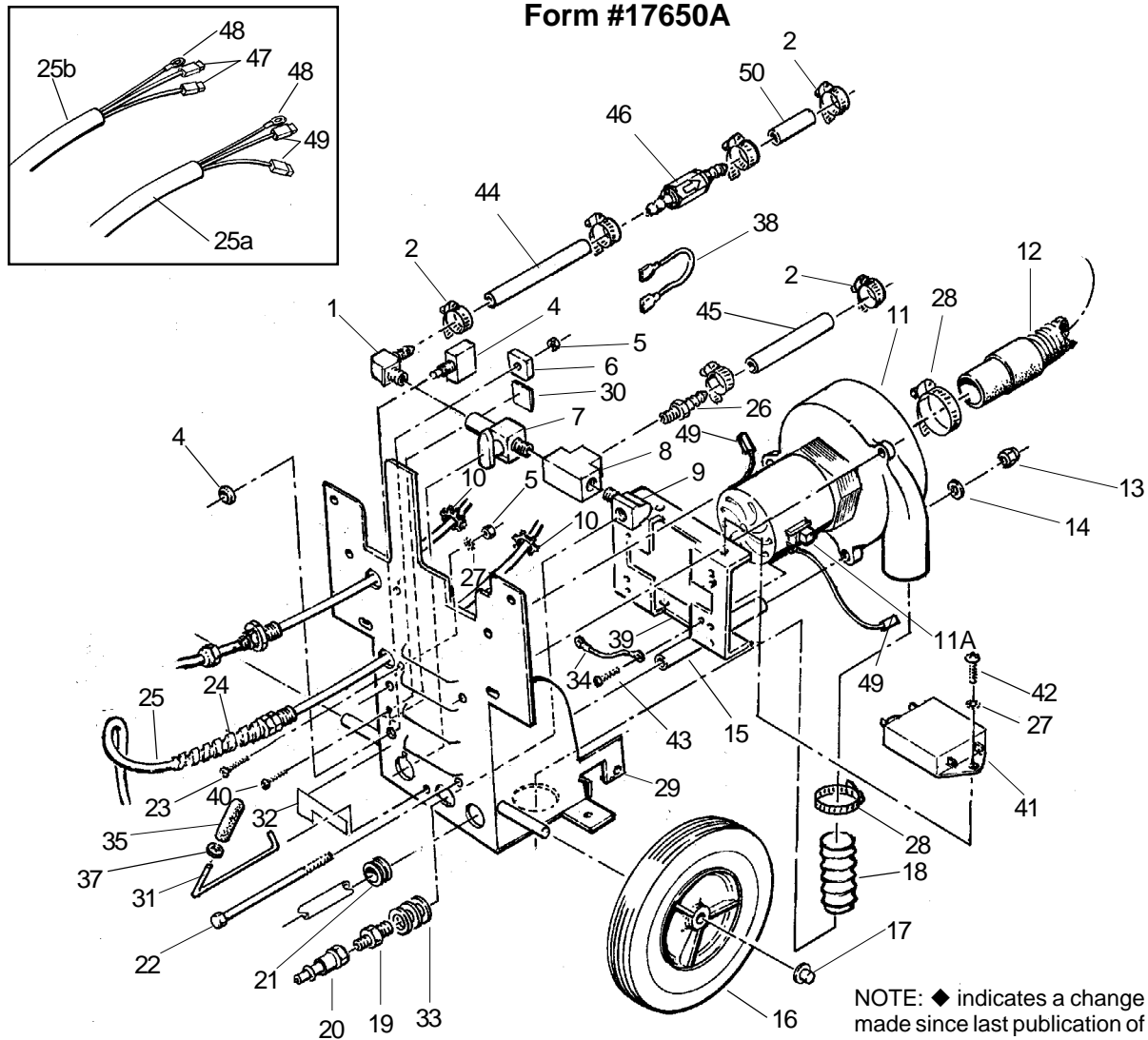

| Ref. | Part No. | Description | Qty | Ref. | Part No. | Description | Qty |
|------|----------|---------------------------------|-----|------|----------|------------------------------|-----|
| 1 | 732870 | Elbow, ¼ MPT x ¾ | 1 | 26 | 170030 | Hosebarb, ¾ | 1 |
| 2 | 50248A | Clamp, Hose | 6 | 27 | 980603 | Washer, #10 Ext. Tooth | 4 |
| 4 | 41427A | Breaker, Circuit w/ Nut 120V | 1 | 28 | 872010 | Clamp, Hose | 2 |
| | 41430A | Breaker, Circuit .6A 230V | 1 | 29 | 63536A | Frame Weldment | 1 |
| 5 | 920224 | Nut, Hex 10-32 | 3 | 30 | 77094A | Label, Ground | 1 |
| 6 | 46103A | Rectifier | 1 | 31 | 57424A | Brush Height Rod | 1 |
| 7 | 59728A | Valve, Plug | 1 | 32 | 77345A | Label, Accessory | 1 |
| 8 | 170066 | Tee, Brass ¼ | 1 | 33 | 980410 | Washer | 3 |
| 9 | 170040 | Elbow, Street ¼ | 1 | 34 | 954010 | Wire, Ground | 1 |
| 10 | 82100A | Locknut, ½ | 2 | 35 | 32411A | Cover, Brush Height Rod | 1 |
| 11 | 44923A | Motor, Vac 120V | 1 | 36 | 53619A | Adaptor ¼NPT x ¾ Barb | 1 |
| | 44924A | Motor, Vac 230V | 1 | 37 | 87626A | Washer | 1 |
| 11a | 40833A | Brush Asm., Carbon (2-required) | 1 | 38 | 49080A | Wire, Main Power | 1 |
| 12 | 30419A | Hose, Vac Squeeze | 1 | 39 | 69894A | Bracket (230V only) | 1 |
| 13 | 81102A | Nut, Stop Elastic | 3 | 41 | 47201A | Supressor (230V only) | 1 |
| 14 | 87026A | Washer, .250 Flat | 3 | 42 | 962987 | Screw, 10-24 x ¾ (230V only) | 2 |
| 15 | 58537A | Spacer, Vac Motor | 3 | 43 | 85833A | Screw, 10-32 x ¾ | 1 |
| 16 | 59951A | Wheel, 8" | 2 | 44 | 35176A | Hose, Solution | 1 |
| 17 | 920346 | Palnut | 2 | 45 | 35147A | Hose, Solution | 1 |
| 18 | 674111 | Hose, Exhaust, Dual | 1 | 46 | 59621A | Check Valve, Solution | 1 |
| 19 | 697501 | Reducer, ¼ NPT | 1 | 47 | 47711A | Terminal (230 V) | 2 |
| 20 | 737140 | Quick Disconnect | 1 | 48 | 911933 | Terminal | 1 |
| 21 | 611101 | Bushing, Motor | 1 | 49 | 47704A | Terminal (120V) | 1 |
| 22 | 85742A | Screw, ¼-20, 5.00 | 3 | 50 | 35172B | Hose | 1 |
| 23 | 85608A | Screw, 10-32 x ¾ | 1 | 51* | 40164A | Cord Asm., 35' Power 120V | 1 |
| 24 | 58013A | Strain Relief | 1 | 52** | 40149A | Cord Asm., Power 230V | 1 |
| 25 | 42188A | Cord, Power 120V | 1 | | | | |
| | 42235A | Cord, Power 230V | 1 | | | | |

CLARKE TECHNOLOGY Image 14 115V
Drawing and Parts List 10/97
Brush/Pump Unit

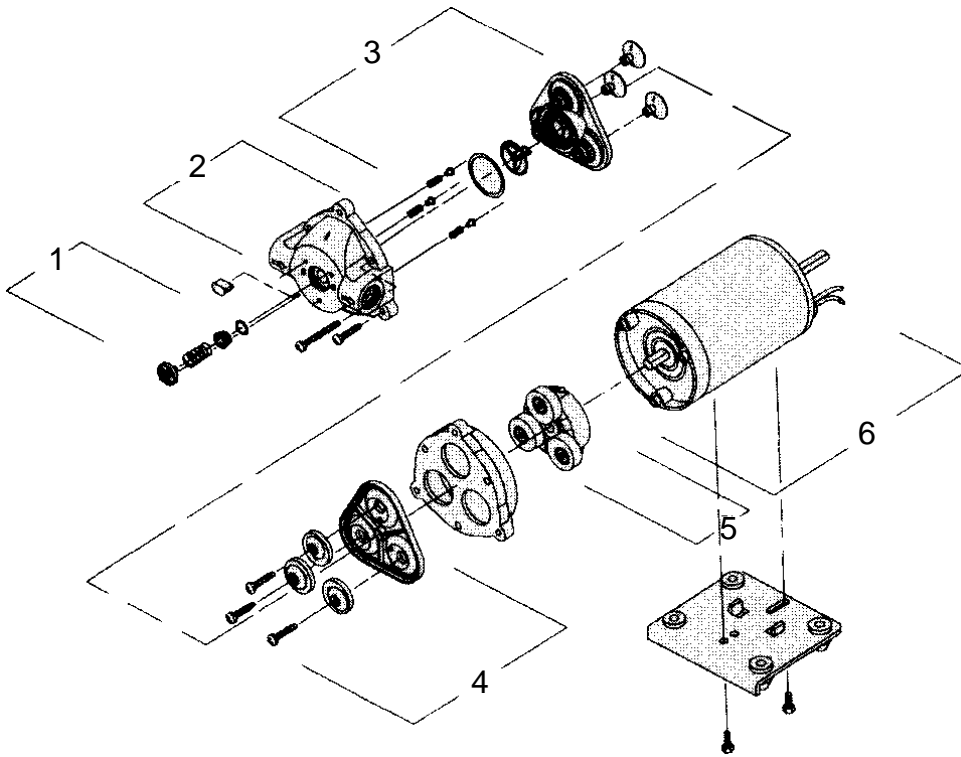

| Ref. | Part No. | Description | Qty |
|------|----------|----------------------------|-----|
| 1 | 55446A | Check Valve Assembly | 1 |
| 2 | 55447A | Kit, Upper Housing | 1 |
| 3 | 55448A | Kit, Bypass Valve Assembly | 1 |
| 4 | 55449A | Kit, Diaphragm | 1 |
| 5 | 55450A | Kit, Drive Assembly | 1 |
| 6 | 44926A | Motor | 1 |
| 7 | *55174A | Head, Pump, 45 psi | 1 |

NOTE: *55174A (includes # 1,2,3,& 4 assembled)

CLARKE TECHNOLOGY Image 14 120 Volt Connection Diagram 3/98

CONTROL HANDLE

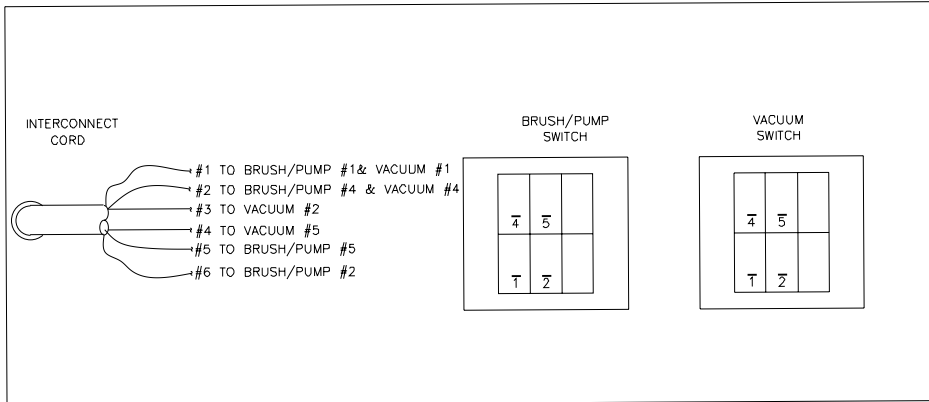

MAIN FRAME

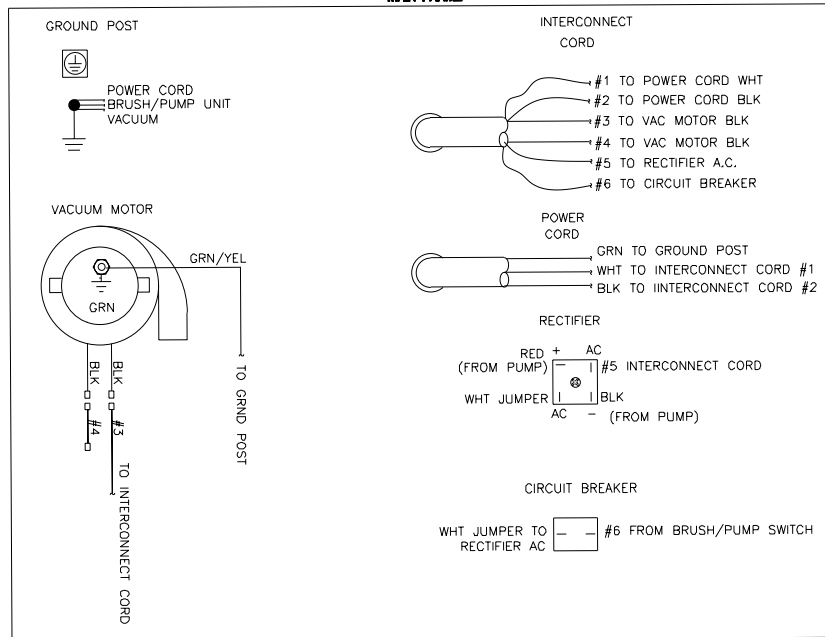

BRUSH/PUMP FRAME

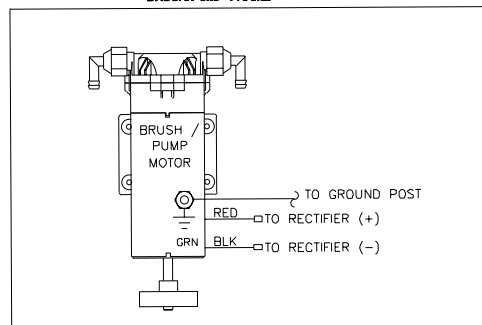

CLARKE TECHNOLOGY Image 14 120 Volt Electrical Schematic 03/98

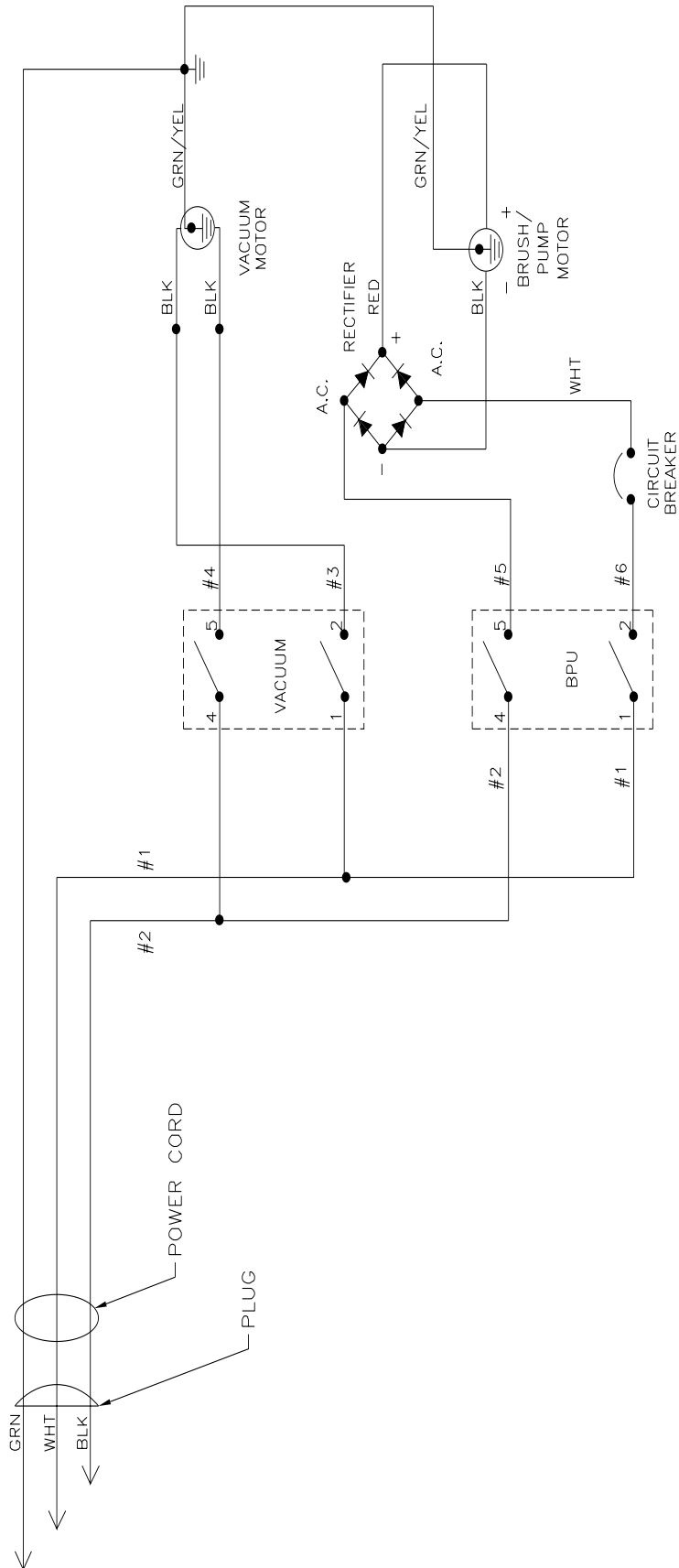

CLARKE TECHNOLOGY Image 14 230 Volt Connection Diagram 4/98

CONTROL HANDLE

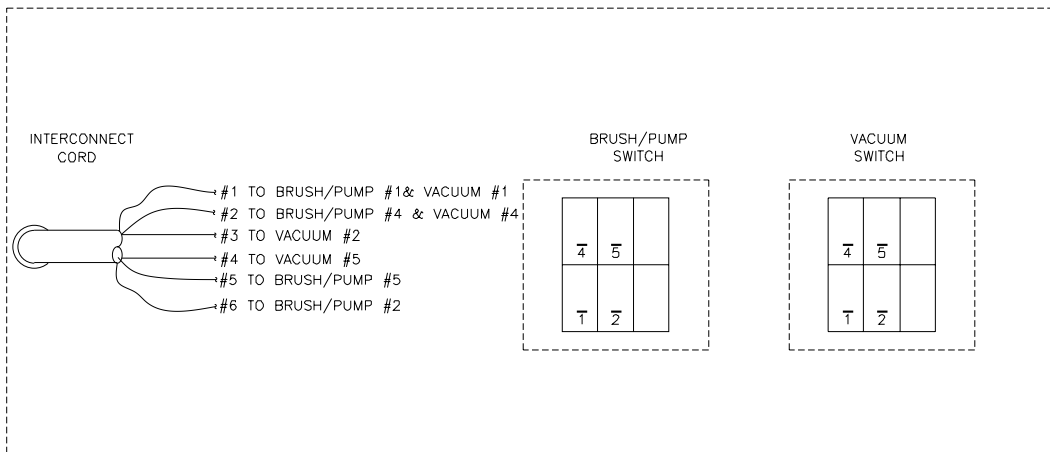

MAIN FRAME

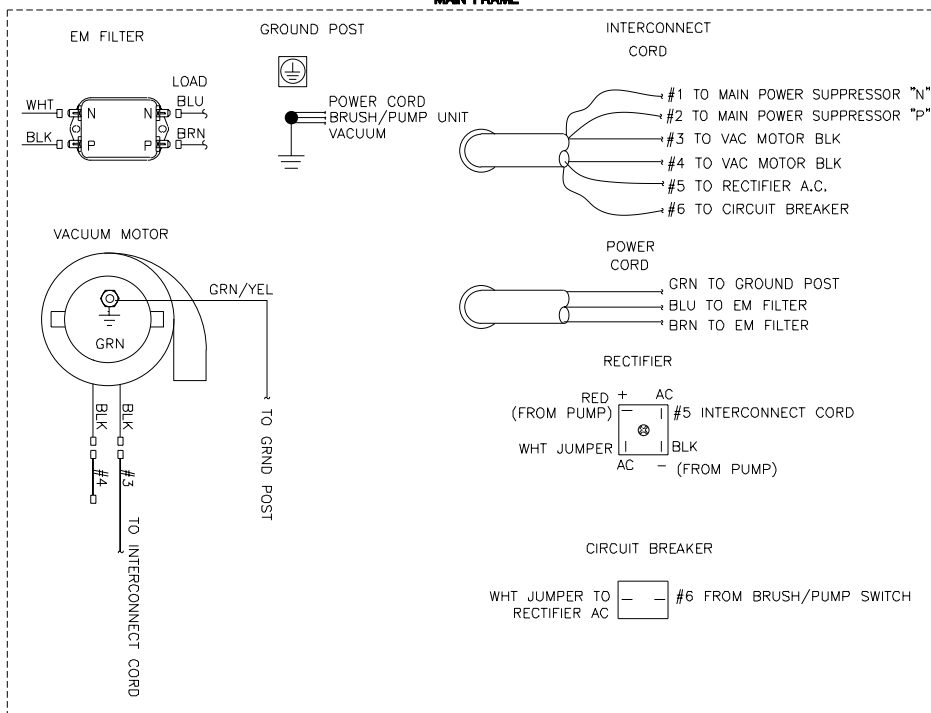

BRUSH/PUMP FRAME

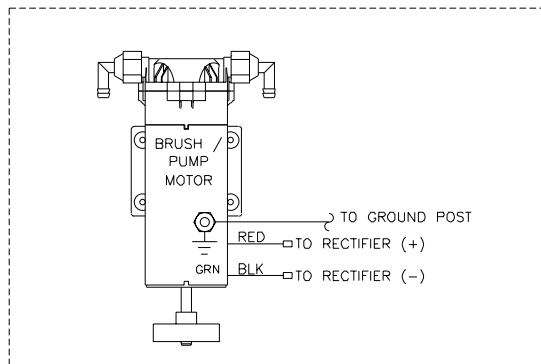

**CLARKE TECHNOLOGY Image 14
230 Volt Electrical Schematic 7/00**

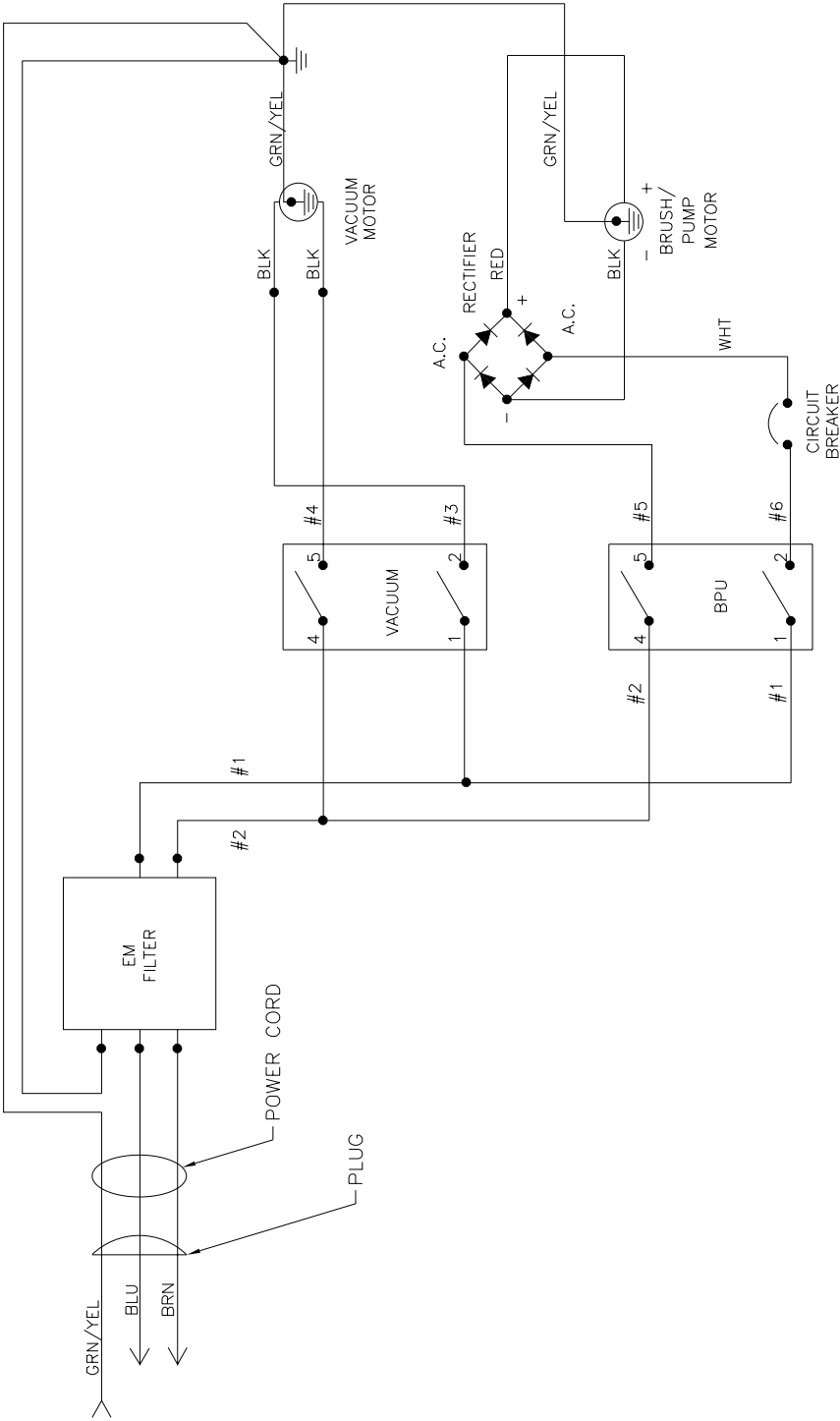

Authentic CLARKE TECHNOLOGY Products 9/01

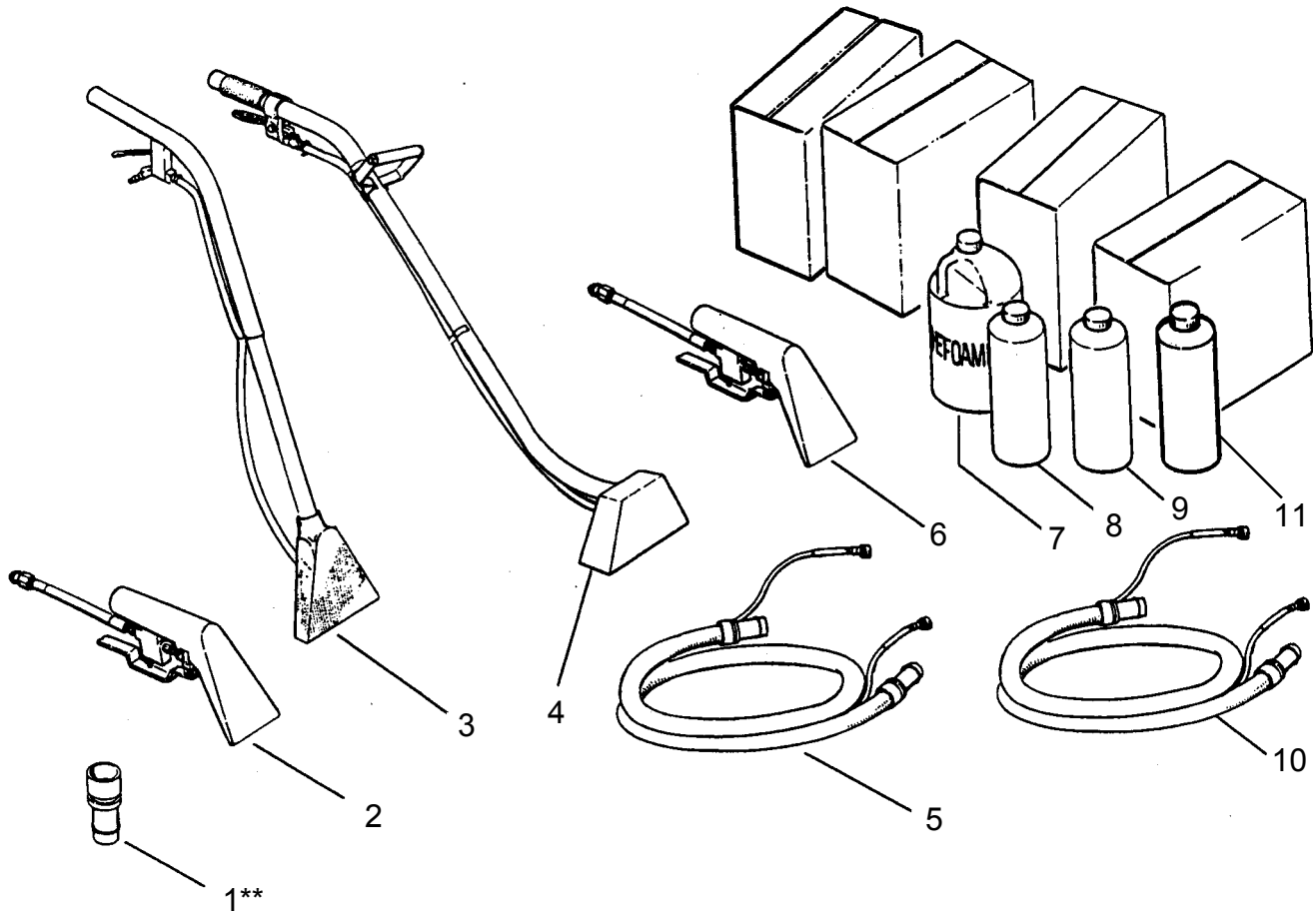

| Ref | Part No. | Description | Qty |
|-----|----------|--------------------------------|---------|
| 1 | 30108A | Adaptor, 2" to 1½" | 1 |
| 2 | 59231A | RM-4P Tool Assembly | 1 |
| 3 | 59230A | RM-8P Tool Assembly | 1 |
| 4 | 59229A | RM-12M Tool Assembly | 1 |
| 5 | 59232A | Hide-A- Hose 10' | 1 |
| 6 | 59228A | RM-4M Tool Assembly | 1 |
| 7 | 398426 | Defoamer | *1 case |
| 8 | 398425 | Extractor, Concentrate | *1 case |
| 9 | 398427 | Traffic Lane/Spot Cleaner | *1 case |
| 10 | 55183A | Hide-A-Hose 20' | 1 |
| 11 | 52953A | General Purpose Spot Cleaner | 1 case |
| ASM | 55173A◆ | 4" Hand Tool and 10' Hose Asm. | 1 |
| NI | 68204A◆ | Coupler, 1½" Hose Connector | 1 |

* 4, 1 gallon bottles

**Required to use any accessory

NOTE: ◆ indicates a change has been made since last publication of this manual.

ALTO® PRODUCT SUPPORT BRANCHES

U. S. A. Locations

HEAD OFFICE

ALTO U.S. Inc., St. Louis, Missouri
16253 Swingley Ridge Road, Suite 200
Chesterfield, Missouri 63017-1725

PRODUCTION FACILITIES

ALTO U.S. Inc., Springdale, Arkansas
2100 Highway 265
Springdale, Arkansas 72764
(501) 750-1000
Customer Service - 1-800-253-0367
Technical Service - 1-800-356-7274

ALTO U.S. Inc., Bowling Green, Ohio 43402
1100 Haskins

SERVICE FACILITIES

ALTO U.S. Inc., Carlstadt, New Jersey 07072
150 Commerce Road
(201) 460-4774

ALTO U.S. Inc., Elk Grove, Illinois 60007
2280 Elmhurst Road
(847) 956-7900

ALTO U.S. Inc., Denver, Colorado 80204
1955 West 13th Ave.
(303) 623-4367

ALTO U.S. Inc., Houston, Texas 77040
7215 North Gessner Road

SALES AND SERVICE FACILITIES

ALTO U.S. Inc., Madison Heights, Michigan 48071-0158
29815 John R.
(810) 544-6300

ALTO U.S. Inc., Marietta, Georgia 30062
1355 West Oak Common Lane
(770) 973-5225

CLARKE TECHNOLOGY
AMERICAN SANDERS TECHNOLOGY
A.L. COOK TECHNOLOGY
Customer Service Headquarters and Factory
2100 Highway 265
Springdale, Arkansas 72764
(501) 750-1000

Technical Service
1-800-356-7274

European Locations

PRODUCTION FACILITIES

ALTO Danmark A/S, Aalborg
Blytaekkervej 2
DK-9000 Aalborg
+45 72 18 21 00

ALTO Danmark A/S, Hadsund
Industrikvarteret
DK-9560 Hadsund
+45 72 18 21 00

SALES SUBSIDIARIES

ALTO Canada Ltd., Rexdale Ontario
24 Constellation Ct.
(416) 675-5830

ALTO Overseas Inc., Sydney (Australia)
1B/8 Resolution Drive
Caringbah NSW 2229
+61 2 9524 6122

ALTO Cleaning Systems Asia Pte Ltd., Singapore
No. 17 Link Road
Singapore 619034
+65 268 1006

ALTO Deutschland GmbH, Bellenberg (Germany)
Guido-Oberdorfer-Straße 2-8
89287 Bellenberg
+49 0180 5 37 37 37

ALTO Cleaning Systems (UK) Ltd., Penrith
Gilwilly Industrial Estate
Penrith
Cumbria CA11 9BN
+44 1768 868 995

ALTO France S.A. Strasbourg
B.P. 44, 4 Place d'Ostwald
F-67036 Strasbourg
Cedex 2
+33 3 8828 8400

ALTO Nederland B.V. Vianen
Stuartweg 4C
NL-4131 NJ Vianen
+31 347 324000

ALTO Sverige AB, Molndal (Sweden)
Aminogatan 18
Box 4029
S-431 04 Molndal
+46 31 706 73 00

ALTO Norge A/S, Oslo (Norway)
Bjernerudveien 24
N-1266
+47 2275 1770

CLARKE TECHNOLOGY U.S. WARRANTY

This Clarke Industrial/Commercial Product is warranted to be free from defects in materials and workmanship under normal use and service for a period of one year from the date of purchase, when operated and maintained in accordance with Clarke's Maintenance and Operations Instructions.

This warranty is extended only to the original purchaser for use of the product. It does not cover normal wear parts such as electrical cable, rubber parts, hoses and motor brushes.

If difficulty develops with the product, you should:

(a). Contact the nearest authorized Clarke repair location or contact the Clarke Service Operations Department, 2100 Highway 265, Springdale, Arkansas 72764, for the nearest authorized Clarke repair location. Only these locations are authorized to make repairs to the product under this warranty.

(b). Return the product to the nearest Clarke repair location. Transportation charges to and from the repair location must be prepaid by the purchaser.

(c). Clarke will repair the product and or replace any defective parts without charge within a reasonable time after receipt of the product.

Clarke's liability under this warranty is limited to repair of the product and/or replacement of parts and is given to purchaser in lieu of all other remedies, including INCIDENTAL AND CONSEQUENTIAL DAMAGES.

THERE ARE NO EXPRESS WARRANTIES OTHER THAN THOSE SPECIFIED HEREIN. THERE ARE NO WARRANTIES WHICH EXTEND BEYOND THE DESCRIPTION OF THE FACE HEREOF. NO WARRANTIES, INCLUDING BUT NOT LIMITED TO WARRANTY OF MERCHANTABILITY, SHALL BE IMPLIED. A warranty registration card is provided with your Clarke product. Return the card to assist Clarke in providing the performance you expect from your new floor machine.

Alto U.S. Inc., 2100 Highway 265, Springdale, Arkansas 72764.

CLARKE TECHNOLOGY: POLYDUR TANK U.S. EIGHT YEAR GUARANTEE

Your new Image Extractor has a Polydur Tank. Polydur is a rotationally molded, high-density linear polyethylene that won't crack or dent, and withstands most corrosives and temperature extremes. Clarke backs up your Polydur Tank with its eight year guarantee. If a tank breaks, cracks, or leaks, within eight years, it will be replaced free.

CLARKE TECHNOLOGY reserves the right to make changes or improvements to its machine without notice.

Always use genuine Clarke Parts for repair.



**CLARKE TECHNOLOGY
2100 Highway 265
Springdale, Arkansas 72764**